

Terminal Server with Async Data Transport Over IP Networks

SpectraComm ADT Highlights

- Provides secure, high performance, low-cost transfer of async data between sites utilizing IP networks.
- Eight front panel ports, each configurable as terminal server, transport or 2/3-wire contact sense ports.
- At the rear panel, 8 input ports provide 2-wire contact sense and two outputs provide contact action.
- Supports alarm reporting via contact sensing and port alerts between network locations.
- Supports LAN connection to 10/100Base-T Ethernet.
- Supports dial-in access via two external modems at term-serv ports, or two internal modems, if equipped.
- NEBS Level III Certified
- Multi-level passwords, inactivity timers, SSH, Access Control Lists (ACL) and TACACS+ authentication
- (Future) 8-port device in a standalone enclosure will support wireless connectivity via an integral cell modem.

Introduction

The SpectraComm Asynchronous Data Transfer 8-port device (SCADT-8) is designed for low port density applications where terminal server and async data transfer over private IP networks are required. NEBS-certified SC-ADT can be deployed in the network where asynchronous devices, craft port equipment or contact relays are located. *Figure 1* shows SC-ADT supporting multiple applications simultaneously:

- From the Management Station, SC-ADT units are managed via Telnet, SSH, SNMP, FTP, TFTP and HTTP.
- At SC-ADT sites, some async ports are configured as terminal server ports, some for contact sensing, some to exchange async data with other sites, some for external modem connections, and some for bypass transport (port forwarding).
- Rear panel DB-25 connector provides single switch contact ports for alarm transfer/traps. Front panel ports are configurable for 2/3-wire contact sensing.

Figure 1: END-TO-END APPLICATIONS

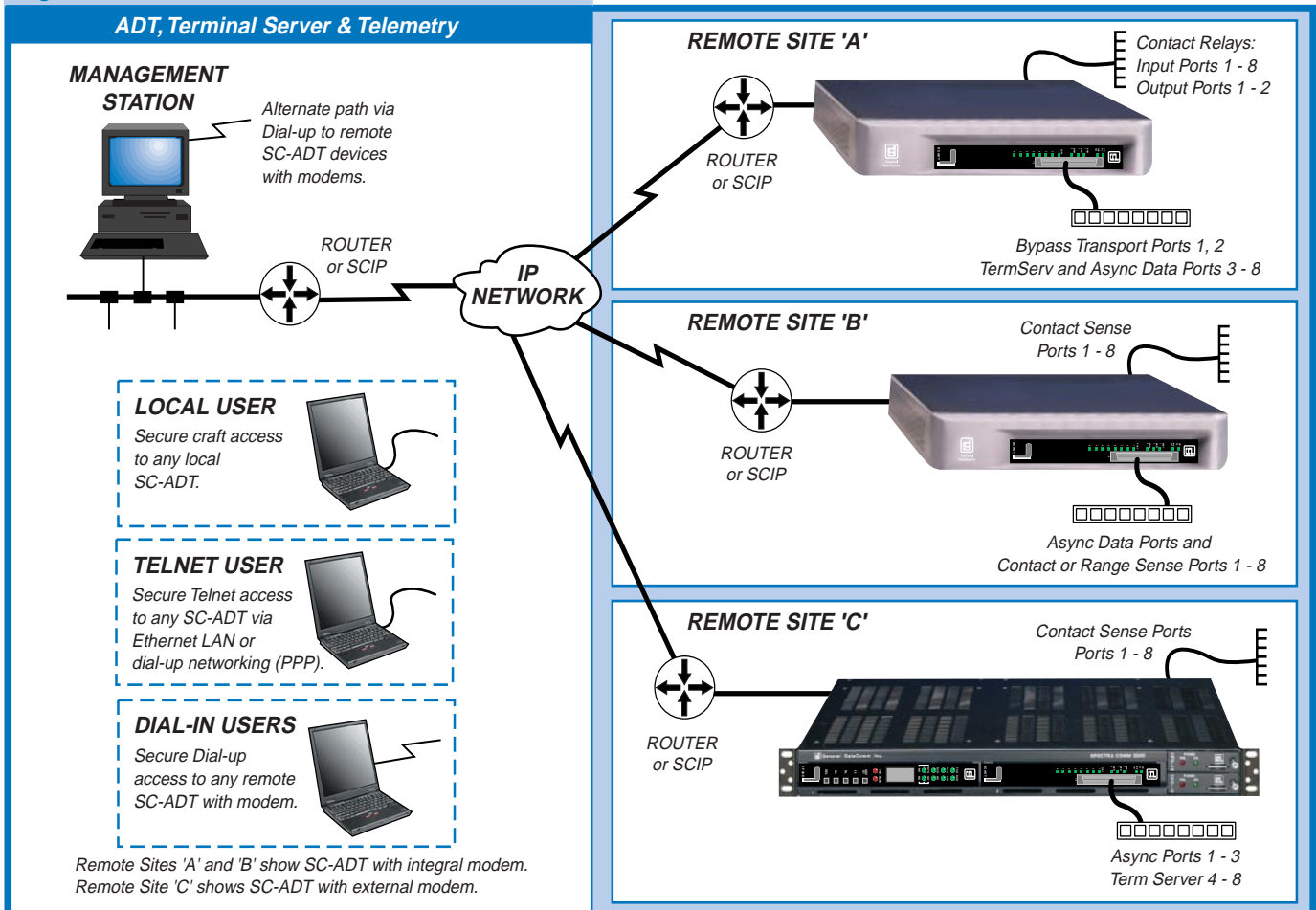

Additional Features

- Authenticated, high performance, low-cost transfer of async data between sites utilizing IP networks.
- Front panel async ports in 8-port increments, configurable as terminal server ports, as 2/3-wire contact sense ports, or for data transport.
- Rear panel DB25 for local management, or for use as 2-wire contact sense ports (8 input ports, 2 output ports).
- Supports two external modems for dial-in access. When equipped with internal modems, allows remote access over dial-up connection for initial configuration.
- Supports GDC's Secure Access Modem (SAM), part of the Secure Access Controller System.
- Modem features include autoanswer/callback mode, caller ID, modem authentication, modem activity logging. Supports enable/disable modem authentication, caller ID authentication.
- "Run from ram" architecture for increased performance and configuration integrity.
- Front Panel LEDs indicate traffic, power and status.
- Acts as terminal server to connect local craft devices, allowing management from anywhere in the network via Telnet/SSH, or optionally via modem dial-in access.
- Supports LAN connection to 10/100Base-T Ethernet. Auto-negotiates for 10 or 100 Mbps port speed, full- or half-duplex modes and enabled/disabled flow control. Auto-senses (HP MID/X) for straight-thru or crossover cable connections.
- Monitored and configured via GDC's interactive "Smart CLI" command line interface at the local VT100 craft port, a Telnet connection, or at the web-based CLI.
- Supports firmware (Flash) downloads via FTP or TFTP protocols. Efficient configuration of multiple SC-ADT devices via ASCII batch file upload/download.
- Supports remote management using standards-based IP protocols such as Telnet, SSH, FTP, TFTP, SNMP and HTTP (web). Supports ping on all interfaces.
- Supports discovery, statistics, and alarm traps using standards-based SNMP.
- Provides EIA lead status for each port.
- Disconnect/connect control strings for each port.
- Supports terminal server port pooling and port alerts.
- Low power consumption (6 watts maximum per slot).
- Telnet/SSH "cut-thru" to eight craft ports attached to the front panel terminal server connector; Terminal server menu access to individual ports or to the CLI interface.

Figure 2: FRONT PANEL VIEWS

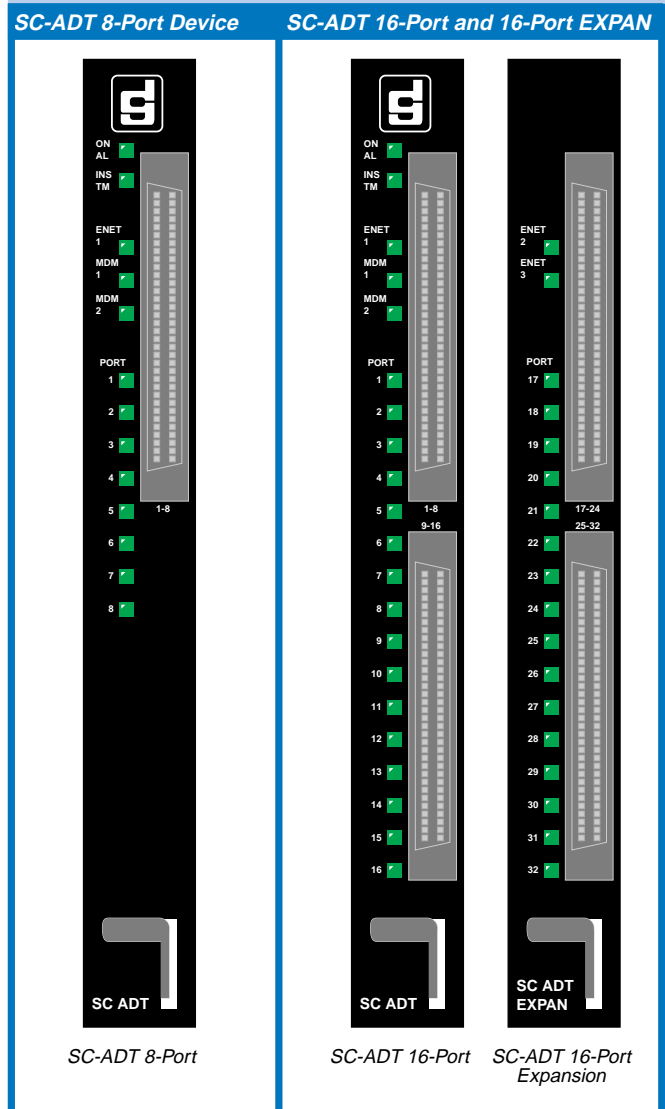

- Multi-level passwords, inactivity timers, access control lists (ACL), and TACACS+ authentication.
- GMT time-stamp on SNMP traps and on events in the System Message log and Alarm log.
- Enable/disable HTTP, SNMP, Telnet, SSH, FTP and TFTP services by individual interface. Diagnostics for async loopbacks, ping and statistics.
- Supports per port Datakit simulation in legacy networks where Datakit nodes provide the front end to a network management application.
- Port 1/2 can be used in dialup mode (modem required) or in bypass mode for IP transport (port forwarding for NAT transversal, no modem required).
- High density port models of the SC-ADT are available in 16-port or 32-port increments.

8-Port, 16-Port and 32-Port Models

All three models of the SpectraComm ADT are NEBS Level III compliant and are intended for installation in GDC's 'telco-tough' SpectraComm shelves and enclosures. The SC-ADT 8-port device occupies one slot in GDC's 2-slot SC 2000 shelf or 16-slot SC 5000 shelf.

For remote site or non-NEBS, stand-alone applications, the same SC-ADT 8-port card installs in the single-slot SpectraComm SC 1001A (AC) or SC 1002 (DC) enclosure.

For higher density applications, the SC-ADT 16- and 32-port models occupy one or two slots in the GDC's 16-slot SpectraComm 5000 shelf.

Figure 2 illustrates some of the versatile port density applications of SC-ADT devices in SpectraComm shelves/enclosures.

Scalable, Flexible SpectraCommonality

Any SpectraComm device can be co-located in the shelf with SC-ADT cards, providing a unified, flexible, managed shelf environment that is scalable to your network requirements. For example, the SC-ADT can be deployed with the SC-MR1 for applications that also require dynamic routing.

Typical shelf configurations include SC-ADT devices with SpectraComm IP cards (SC-MR1, SCIP-T1, SCIP-E1, SCIP-DSL), SpectraComm Ethernet Switch cards (SC-ES 9-Port or SC-ES 18-Port), as well as GDC SpectraComm modems, multiplexers, DSUs and LTUs.

Figure 3 shows SC-ADT installed in GDC's flexible, scalable shelves and enclosures with other compatible device cards.

Figure 3: SPECTRA-COMMONALITY:

Application Card & Shelf Solutions

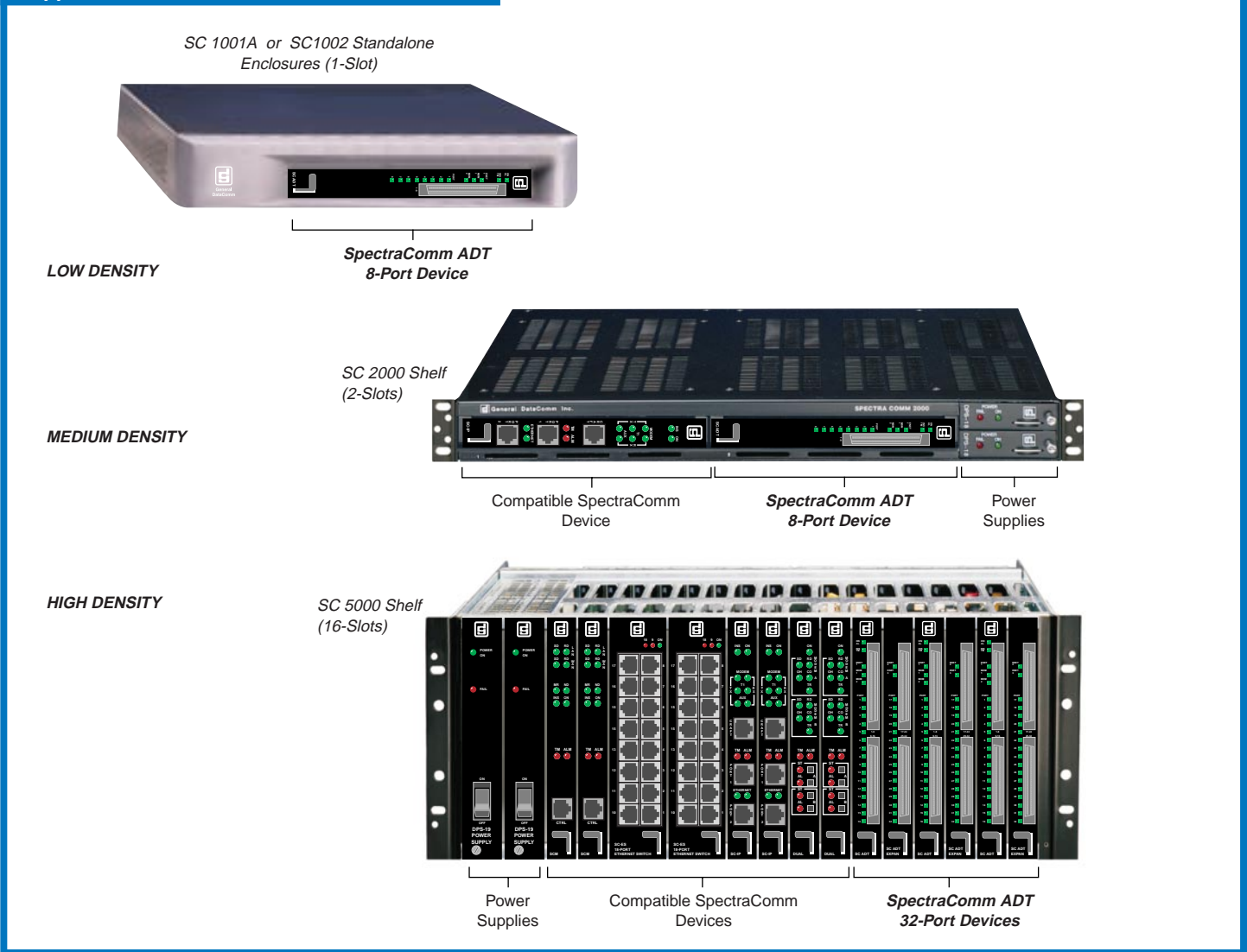

TERMINAL SERVER APPLICATIONS

The SpectraComm ADT front panel connector can be configured as terminal server ports for managing remote equipment through their craft ports. Each port is a standard EIA-232 async interface. Up to eight ports of local asynchronous customer equipment can be managed from anywhere in the customer's network, with an SC-ADT only required at craft equipment sites. To support more async ports, simply add more SC-ADT units to the ethernet segment at each site as required.

Users can directly access the connected craft devices via Telnet or SSH access, modem dial-in access, or via Ethernet LAN. Telnet or SSH users can also access any terminal port from a convenient port menu by selecting its description field or port number. Dial-users can access one terminal server port after another without having to disconnect and redial the modem connection.

Terminal Port Features

As terminal server, SC-ADT offers feature enhancements:

- Up to five user-defined Port Alert strings per port (SNMP traps)
- Port Pooling groups devices into four to eight pools.
- Heightened port security via ACL & TACACS+
- Contact Sensing (SNMP traps)

IP or Dial-in Access

Figure 4 shows craft devices at the SC-ADT site being accessed by users at remote sites over the IP Network, by local users over the Ethernet connection, and by users at remote sites via the modem connections.

IP Network Access

SC-ADT is attached to a local router or a SCIP over 10/100Base-T Ethernet. Users can launch a Telnet/SSH session to a terminal port, thus connecting to the craft device at that port. Several users may connect to several terminal server ports simultaneously as long as they are connecting to different ports.

Modem Access

SC-ADT supports two external modem connections for dial-in access over the PSTN. SC-ADT also supports two integral modems, when so equipped. The external modem connections use two of the eight available async ports. The integral modem connections are separate.

Users dial-in and connect to SC-ADT in Terminal Emulation mode using applications like HyperTerminal or in Dial-up Networking mode for standard IP access.

Two dial-in users may connect to any two separate terminal ports simultaneously. If there is a LAN connection at the SC-ADT site, several more users may Telnet/SSH simultaneously over the LAN to additional craft devices.

Figure 4: TERMINAL SERVER

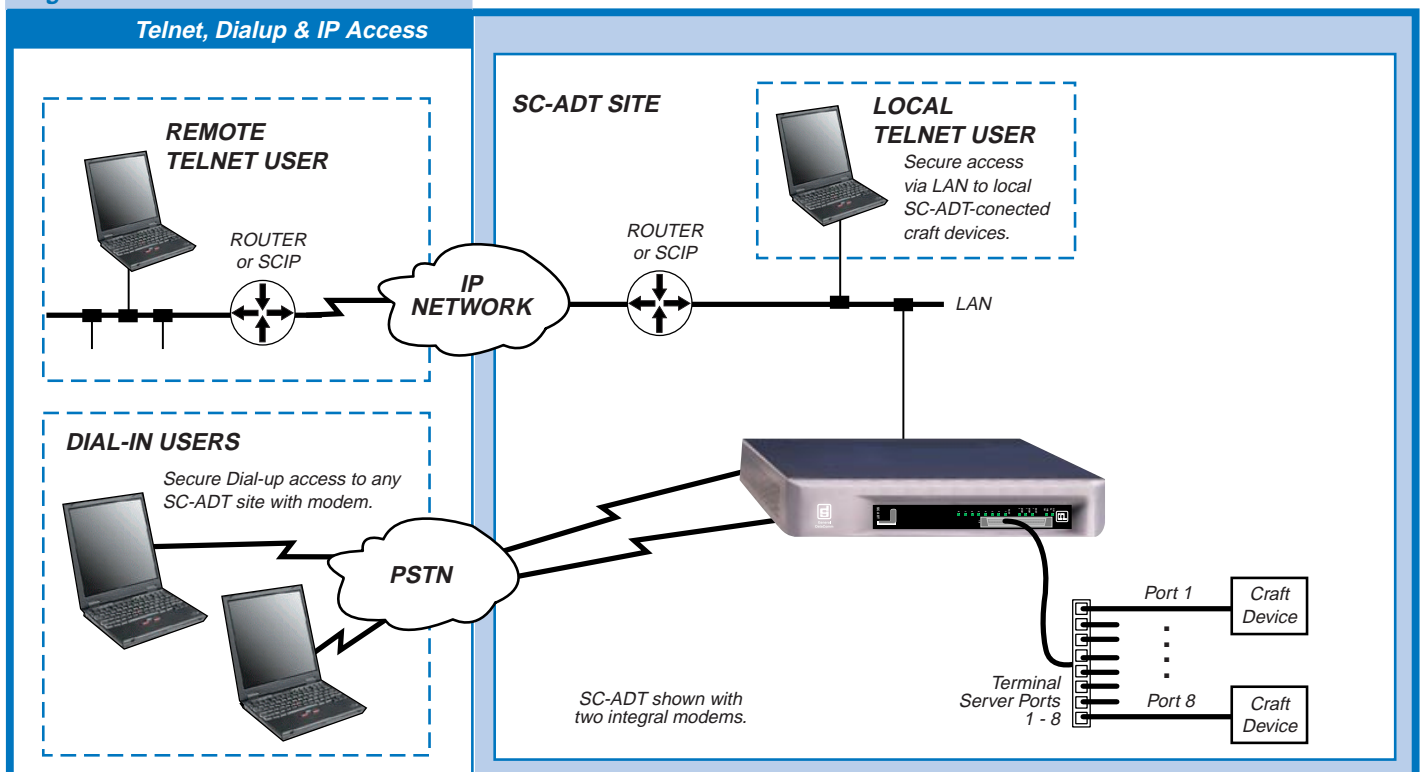

TRANSPORT MODE APPLICATIONS

The ADT application of the SC-ADT utilizes ethernet LAN facilities for end-to-end async data traffic between sites in the customer's IP network. In such applications, async data is received from customer equipment, encapsulated and transferred between sites.

The SC-ADT front panel connector can interface with up to eight local asynchronous customer equipment ports. For higher density requirements, simply adding more SC-ADT devices will attach additional devices to the ethernet segment at each site in 8-port increments.

Individual async data ports are configurable for Baud, Data/Start/Stop Bits, Parity, and DTE/DCE type. External adapters allow connections to either terminal (DTE) or modem (DCE) devices.

Theory of Operation

The SC-ADT encapsulates the async traffic into IP Packets and forwards the data over Ethernet to the local router/bridge, or to a companion product, the SpectraComm IP device, for transfer over the IP network.

The async data at any local SC-ADT port can be forwarded to any async port at any remote SC-ADT location using a set of lookup tables maintained in each SC-ADT.

A SC-ADT device is required at both ends of a link to support the proprietary encapsulation scheme.

Figure 5 shows multiple sites with async equipment linked together over the customer's IP Network. Any DTE at any SC-ADT site can exchange async traffic with any other DTE.

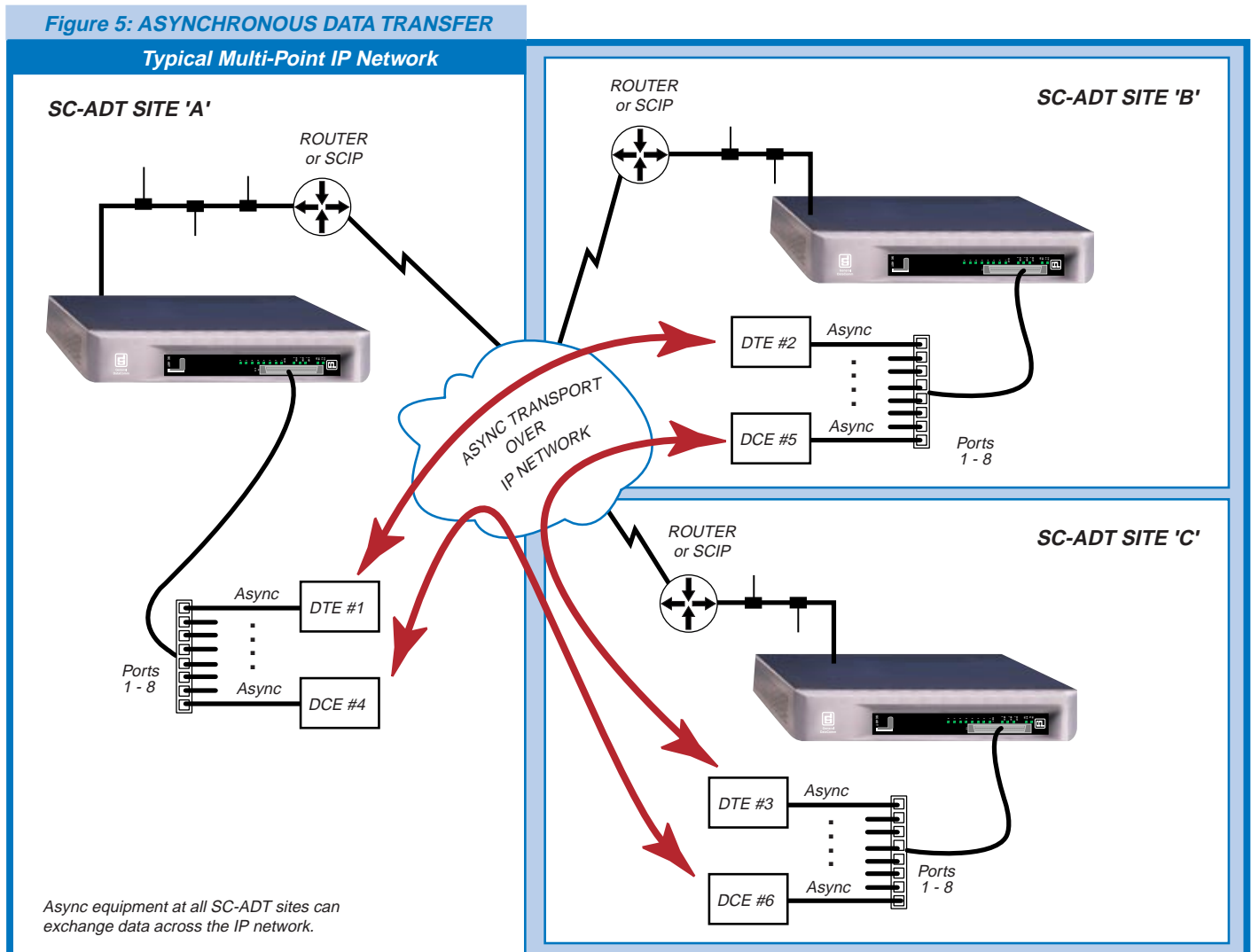

CONTACT SENSE APPLICATIONS

The SpectraComm ADT rear panel DB-25 connector can perform contact sensing/contact action and can be configured for alarm notification whenever a change in contact relays occur at customer network sites. This provides up to eight input ports for 2-wire sensing via an attached dry contact device, and up to two output ports for controlling site devices, e.g., toggle power, reset, turn on fans, etc.

In addition, any SC-ADT front panel port can be configured for normal 2-wire contact sensing, or 3-wire range sensing (Hi/Lo), depending on the capability of the attached dry contact device at the site.

Theory of Operation

SC-ADT detects when a contact changes from its normal state and, depending on its configuration, will send an alarm trap, transport the contact state, or perform both trap and transport actions. A 'clear' trap is sent when the contact returns to the normal state. SC-ADT devices are required at both sites to transport contacts, whereas a SC-ADT device is not required to receive traps. Any Management Station in the network can be a trap destination.

Configuration Options

Normal sensing will track open/closed contact state changes at a remote location. Range sensing will track high and low states (temperature, pressure, voltages, etc.). Alarm notification is user-configured to one of three options:

SNMP Trap

After sensing a relay state change from the normal state (open or closed), an alarm trap is sent to a management station using an SNMP alarm trap.

Contact State Transport

After sensing a relay state change, a message is sent to a remote SC-ADT device to open or close a relay at that site.

Trap and Transport

The alarm will be transported between sites and a trap will be sent to a management station. The destinations for alarm transport and Trap are independent.

Figure 6 shows the SC-ADT in a typical contact sense (alarm) application with SNMP traps sent to a Management Station, and a contact transport message sent to another SC-ADT site.

Figure 6: CONTACT SENSING APPLICATIONS

Typical Multi-Point IP Network with Contact "Trap & Transport"

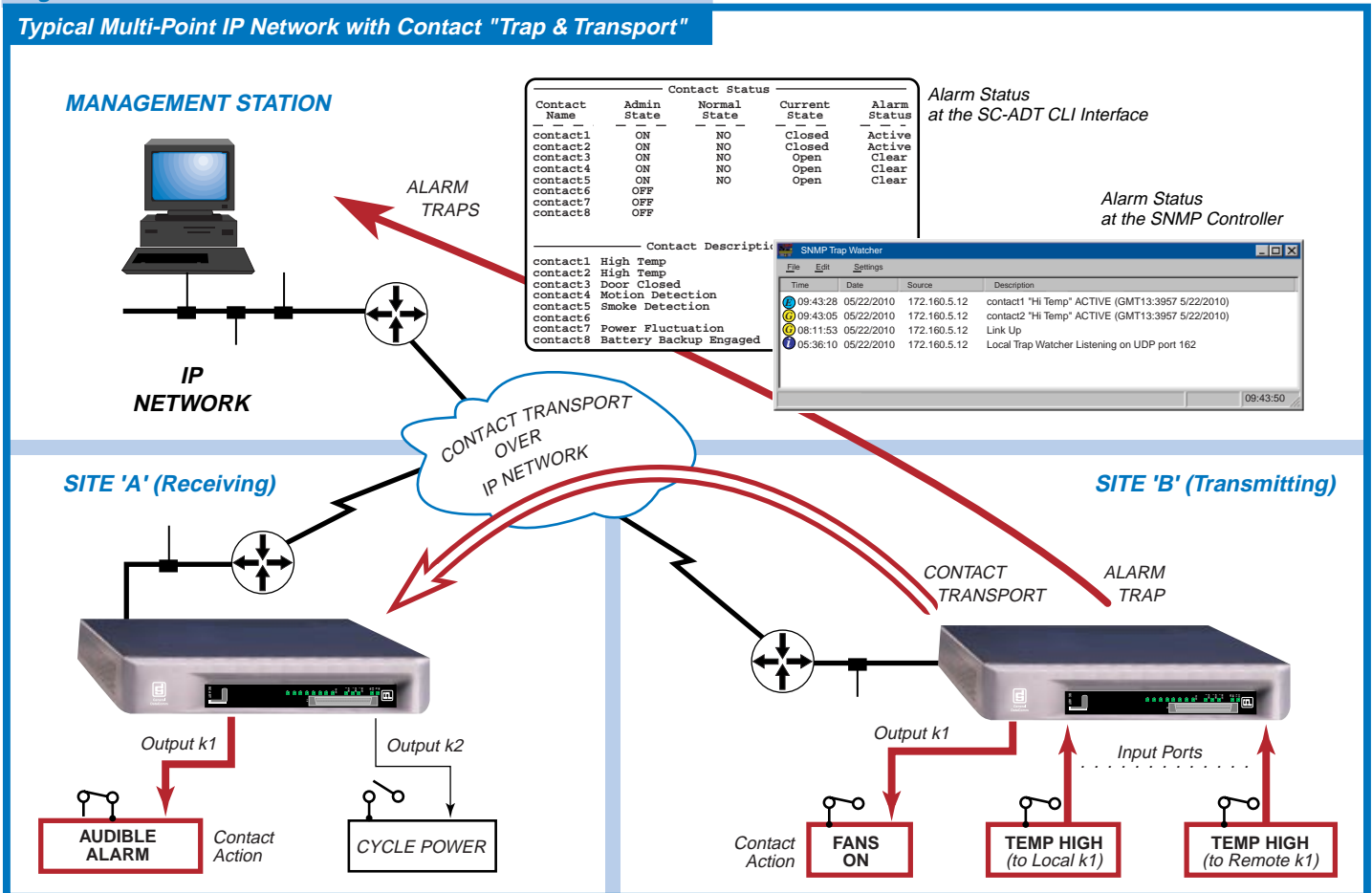

SC-ADT MANAGEMENT

SC-ADT configuration is managed through SMART CLI, an interactive command line interface, or through graphical user interface (GUI) web screens. Through these interfaces, an authorized user can monitor or configure any SC-ADT device in the network via a terminal or Telnet connection or through any popular web browser.

Secure Access and Protection

Management access to SC-ADT through CLI and web interfaces is protected by several security features:

- User- and Supervisor-level password protection authorizes every access attempt.
- Configurable inactivity timers for CLI, Port Activity and DUN Activity, as well as fixed inactivity timers and overrides.
- Access control: Enable/Disable Telnet, SSH, SNMP, HTTP, FTP, TFTP services to deter hacking via these protocols.
- Enable/Disable management traffic by interface, for provider and customer management access schemes.
- TACACS+ protocol off-loads user authentication to a central server, providing 'centralized' security.
- Access Control List (up to 200 IP addresses) blocks unauthorized IP addresses from connecting with ports.

SMART CLI Features

General DataComm's SMART CLI has a look and feel that will be familiar to most field personnel, with the benefit of several enhancements over most standard CLIs, such as:

- Command entry from a Telnet, SSH or terminal connection, or using a standard browser.
- Recognition and auto-expansion of abbreviated commands and sub-commands.
- Auto-prompts for required command arguments.
- General help at the command prompt; Context-sensitive help at the command string.
- Command line recall for easy re-entry or review of previous commands.
- Advanced utility for generating downloadable ASCII configuration files as batch scripts.
- Upgradable via FTP or TFTP downloads of SC-ADT software versions and configuration data.

Web-Based Management

An integral HTTP server provides password-protected access to a web-based CLI interface. Authorized users can monitor or change SC-ADT configuration and operation parameters in a streamlined logical graphical user interface using any popular web browser.

Figure 7: MANAGEMENT INTERFACE OPTIONS

Flexible, Secure and SMART

IP Management Access to any SC-ADT unit

Management Station

Alternate OOB management path via Dial-Up

Local management via Craft Port

Terminal or Telnet CLI Interface Option

```

SC-ADT% configure
Type "configure ?" for a list of subcommands
SCIP-ADT% configure ?
Help for "configure"
accounts      Configure usernames and passwords
banner        Configure login banner
contact        Configure contact sense parameters
inactivity     Configure CLI inactivity timer; requires 1 parameter(s)
interfaces     Configure interface parameters
ip-route       Configure ip static route table
modem          Configure modem parameters
ports          Configure port parameters
prompt         Configure custom prompt; requires 1 parameter(s)
services       Configure HTTP, SNMP, TELNET, TFTP & FTP Services
snmp           Configure SNMP Server parameters
syslog         Configure sending SYSMSGs to remote SYSLOG servers
tacacs+        Configure TACACS+ query parameters
time           Configure time service parameters
SC-ADT% configure _
                    
```

Web-based Interface Option

SpectraComm ADT

YOUR SYSTEM NAME (172.16.5.127)

clear	Reset functions
configure	Configure system parameters
help	Description of the command line interface and help system
show	Show system parameters
reboot	Halt and perform a reboot
netstat	Show TCP socket connections
services	Show/Enable/Disable HTTP, SNMP, & TFTP Services
tutorial	Display tutorials for SC-ADT

All SC-ADT devices are simultaneously configurable for ADT, Terminal Server or Contact Sense applications.

DialUp access is available on SCIP devices equipped with an integral modem or operating with a compatible external V.34 modem.

Centralized and Versatile Options

Figure 7 shows management throughout the network from the central site. SC-ADT units can also be accessed via a craft connection from a VT100-compatible terminal, a Telnet connection, or a web browser. Authorized remote dial-in users can access SC-ADTs equipped with an internal or external modem.

SC-ADT Physical Specifications

SpectraComm ADT 8-Port Dimensions

Width: 178 mm (7.0 in)
Height: 21 mm (0.81 in)
Depth: 241 mm (9.5 in)
Weight: 0.28 kg (10 oz); Shipping Weight: 0.74 kg (1 lb 10 oz)

Environmental Specifications

Non-Operating

Temperature: -40 to 70 degrees C (-40 to 158 degrees F)
Relative Humidity: 5% to 95%
Altitude: up to 12,191 m (40,000 ft)

Operating

Temperature: 0 to 50 degrees C (32 to 122 degrees F)
Relative Humidity: 5% - 90% non-condensing
Altitude: -60 to 4,000 m (-197 to 13,123 ft)

Electrical Characteristics

Power (AC or DC), voltage, frequency, and fusing determined by your SpectraComm shelf or enclosure.

Power Dissipation: 6 Watts per slot maximum

Compliance & Compatibility

Safety: UL Approved
NEBS Level III Certified
EMI: FCC Part 15 Class A Approved
Telco: FCC Part 68 Approved
Quality Assurance: ISO 9001:2000 Certified

Management Options

Command line interface via VT100-compatible terminal
Command line interface via Telnet or SSH.
HTTP interface via embedded web-server agent using PC browser. (Supports HTML)
SNMP support for discovery, statistics and alarm traps:
MIB for Network Management of TCP/IP-based Internets MIB2 (RFC 1213); Ethernet MIB (RFC 1398)
FTP/TFTP support for firmware and configuration maintenance.



Operational Specifications

Physical Interfaces

Craft Port: Standard asynchronous EIA-232 DCE (3-wire) interface at 9600,8,N, 1 for connection to standard VT100-compatible terminal, using rear panel DB-25 connector.

LAN Port (10/100B-T Ethernet) using rear panel RJ-connector.

Eight Async ports using a single front panel 68-pin (D-type) connector.

Eight Contact Relay Input (2-wire) Interfaces and two Output (3-wire) Interfaces on rear DB-25 connector

Data Rates

Maximum: 8 ports at 115.2Kbps

Integral Modem Operation (Optional)

ITU-T V.34 with 9600 bps to 33.6 Kbps line speed

DTE speed up to 115.2 Kbps using:

- V.42 LAPM and MNP 2-3 error correction
- V.42 bis and MNP 5 data compression

Dial-up Access Modes using:

- Terminal Emulation Mode, using a standard ASCII terminal or terminal emulation package like HyperTerminal.
- Dial-up Networking Mode, using standard Dial-up applications.

Monitoring, Diagnostics & Statistics

Transmit and Receive packet counts on Ethernet interface.

Transmit and Receive byte counts on Ethernet interface.

Transmit and Receive character counts on Async ports.

Transmit and Receive byte counts on Management IP address (optional).

Generates/answers pings

Tests Contact States (via 2-wire Normal or 3-wire Range Hi/Lo sense)

Loopback on Async ports

Port Alerts

Trace-Route

SNMP Traps: Cold Start, Linkup/down for e0, Link up/down for m0, Contact Sense start/stop, Contact Sense active/clear, ACL violation, Port Alerts

Logs & Status: Sysmsg log, History log, Modem activity log, Alarm log, Port status, Network statistics,

Security and Authentication

Username and Password verification

Multi-level permissions: User (Read-only), Supervisor (Read-Write), or Administrator (Read-Write and special functions)

Individual disable/enable of Telnet, SSH, HTTP, SNMP, FTP, TFTP access

Configurable timeouts for CLI activity, Port activity, DUN activity

Fixed timeouts for Dialup Service menu, Dial-up Port menu, Telnet/SSH Port menu, Authentication, Telnet/SSH Override, Modem Override.

TACACS+ Authentication Protocol (optional)

Access Control List (ACL)