

OPERATING AND INSTALLATION INSTRUCTIONS
FOR

DataComm 552A-1
VERSION 1.1
DATA SERVICE UNIT



General DataComm, Inc.
MIDDLEBURY, CONNECTICUT
06762-1299



ATTENTION! STATIC SENSITIVE DEVICES

PROPER HANDLING AND GROUNDING PRECAUTIONS REQUIRED

This equipment contains electrostatic sensitive devices. Use ESD precautionary procedures when removing or inserting parts or printed circuit (pc) cards. Keep parts and pc cards in their antistatic packaging material until ready to install.

The use of an antistatic wrist strap, connected to the grounded equipment frame or chassis, is recommended when handling pc cards during installation, removal, or setting of on-board option switches. Do not use a conductive tool, such as a screwdriver or paper clip, to set the position of the option switches.

INSTALLATION SAFETY INSTRUCTIONS

- a. Never install telephone wiring during a lightning storm.
- b. Never install telephone jacks in a wet location unless the jack is specifically designed for wet locations.
- c. Never touch uninsulated telephone wires or terminals unless the telephone line has been disconnected at the network interface.
- d. Use caution when installing or modifying telephone lines.

CAUTION

Potentially hazardous voltages exist within this unit.

**DataComm 552A-1
VERSION 1.1
DATA SERVICE UNIT**

(GDC PART NOS. 048A070-101, -111 and 048M070-101, -111)

This product was designed and manufactured by



General DataComm, Inc. (GDC)
Middlebury, Connecticut 06762-1299

WARNING

This equipment has been tested and found to comply with the limits for a Class A digital device, pursuant to Part 15 of the FCC rules. These limits are designed to provide reasonable protection against harmful interference when the equipment is operated in a commercial environment. This equipment generates, uses and can radiate radio frequency energy and, if not installed and used in accordance with the instruction manual, may cause harmful interference to radio communications. Operation of this equipment in a residential area is likely to cause harmful interference, in which case the user will be required to correct the interference at his own expense. To comply with FCC Part 15 Class A, the following instructions must be implemented: **ALL** cables need to be shielded cables, bundled and grounded.

The user is cautioned that any changes or modifications not expressly approved by the party responsible for compliance would void the user's authority to operate the equipment.

CRC-REQUIRED NOTIFICATION

This equipment is a Class A digital apparatus which complies with the Radio Interference Regulations, CRC c.1374.

PUBLICATION NOTICE

This manual has been carefully compiled and checked for accuracy. The information in this manual does not constitute a warranty of performance. Furthermore, GDC reserves the right to revise this publication and make changes from time to time in the content thereof. GDC assumes no liability for losses incurred as a result of out-of-date or incorrect information contained in this manual.

The features described herein may not exist on all versions of the software and are subject to change without notice.

READER'S COMMENTS

Comments regarding this manual should be addressed to:

**Publications Department
General DataComm, Inc.
1579 Straits Turnpike
P.O Box 1299
Middlebury, CT 06762-1299**

PROPRIETARY NOTICE

This publication contains information proprietary and confidential to General DataComm, Inc. Any reproduction, disclosure, or use of this publication is expressly prohibited except as General DataComm, Inc., may otherwise authorize in writing.

USERS OF T1 SERVICE
NOTICE FOR USERS OF FCC-REGISTERED EQUIPMENT
Read before using this technical manual or installing submect equipment.

The following instructions are provided to ensure compliance with the Federal Communications Commission (FCC) Rules, Part 68.

- A. This equipment complies with Part 68 of the FCC Rules. On the underside of this equipment (Standalone enclosure) or just behind the panel (Rackmount enclosure) is a label that contains along with other information, the FCC registration number for this equipment. This information, if requested must be provided to the telephone company.
- B. To connect the DataComm 552A-1 V1.1 DSU to the Public Telephone Network you are required to give the following information to the Telephone Company:
 - 1. The Port ID, which is J1.
 - 2. The FCC Registration Number, which is AG6 USA-18307-DE-N.
 - 3. The FIC (Facility Interface Code), which is 04DU9-B and/or 04DU9-C.
 - 4. The SOC (Service Order Code), which is 6.0F.
 - 5. The Telephone Company jack type, which is RJ48C.
- C. For single and two-line equipment that connects to the telephone network via a plug and jack, the plug and jack must comply with the FCC Part 68 Rules. An FCC compliant telephone modular plug and telephone cord is provided with this equipment. This equipment is designed to be connected to the telephone network or premises wiring, using a compatable modular jack which is Part 68 compliant. See installation instructions for details.
- D. This device has been designed to prevent harm to the T1 network. If the DataComm 552A-1 V1.1 DSU causes harm to the telephone network, the telephone company will notify you in advance that temporary discontinuance of service may be required. But if advance notice is not practical, the telephone company will notify the customer as soon as possible. Also, you will be advised of your right to file a complaint with the FCC if you believe it is necessary.
- E. The telephone company may make changes in its facilities, equipment, operations or procedures that could effect the operation of the equipment. If this happens the telephone company will provide advance notice in order for you to make necessary modifications to maintain uninterrupted service.
- F. If trouble is experienced with the DataComm 552A-1 V1.1 DSU, contact General DataComm Service Corp., 6 Rubber Ave, Naugatuck, CT 06770 phone (203) 729-0271 for repair and/or warranty information. If the equipment is causing harm to the telephone network, the telephone company may request that you disconnect the equipment until the problem is resolved.
- G. In the event the equipment needs repair it must be sent back to the company or listed authorized agent. Under FCC rules, no customer is authorized to repair this equipment. Any repair or modification will render the FCC registration and the warranty of this equipment null and void.
- H. The DataComm 552A-1 V1.1 DSU cannot be used on Public Coin Phone Service or Party Lines. Connection to Party Line Service is subject to state tariffs. Contact the state public utility commission, public service commission or corporation commission for information.

March 1994

CANADIAN DEPARTMENT OF COMMUNICATIONS (DOC) REQUIRED
NOTIFICATION

FOR USERS OF DOC-CERTIFIED EQUIPMENT

Read before using this technical manual or installing subject equipment.

The Canadian Department of Communications label identifies certified equipment. This certification means that the equipment meets certain telecommunications network protective, operational, and safety requirements. The Department does not guarantee the equipment will operate to the user's satisfaction.

Before installing this equipment, users should ensure that it is permissible to be connected to the facilities of the local telecommunications company. The equipment must also be installed using an acceptable method of connection. In some cases, the company's inside wiring associated with a single line individual service may be extended by means of a certified connector assembly (telephone extension cord). The customer should be aware that compliance with the above conditions may not prevent degradation of service in some situations.

Repairs to certified equipment should be made by an authorized Canadian maintenance facility designated by the supplier. Any repairs or alterations made by the user to this equipment, or equipment malfunctions, may give the telecommunications company cause to request the user to disconnect the equipment.

Users should ensure for their own protection that the electrical ground connections of the power utility, telephone lines, and internal metallic water pipe system, if present, are connected together. This precaution may be particularly important in rural areas.

Caution: Users should not attempt to make such connections themselves, but should contact the appropriate electric inspection authority, or electrician, as appropriate.

CANADIAN EMISSIONS REQUIREMENTS

"This digital apparatus does not exceed the (Class A) limits for radio noise emissions from digital apparatus set out in the Radio Interference Regulations of the Canadian Department of Communications."

**AFFIDAVIT FOR THE CONNECTION OF CUSTOMER PREMISES EQUIPMENT
TO 1.544 Mbps AND/OR SUBRATE DIGITAL SERVICES**

For work to be performed in the certified territory of

(Telco's Name)

State of:

County of:

I, ,
(Name) Business Address

representing ,
(Name of Customer)

being duly sworn, state:
(Telephone Number)

I have the responsibility for the operation and maintenance of the terminal equipment to be connected to 1.544 Mbps and/or subrate digital services. The terminal equipment to be connected complies with Part 68 of the Commission's rules except for the encoded analog content and billing protection specifications. With respect to encoded analog content and billing protection:

- I attest that all operations associated with the establishment, maintenance and adjustment of the digital CPE with respect to encoded analog content and encoded billing information continuously complies with Part 68 of FCC's Rules and Regulations.
- The digital CPE does not transmit digital signals containing encoded analog content or billing information which is intended to be decoded within the telecommunications network.
- The encoded analog and billing protection is factory set and is not under the control of the customer.

I attest that the operator(s)/maintainer(s) of the digital CPE responsible for the establishment, maintenance and adjustment of the encoded analog content and billing information has (have) been trained to perform these functions by successfully completing one of the following: (Check appropriate one(s)).

- a. A training course provided by the manufacturer/grantee of the equipment used to encode analog signals
- b. A training course provided by the customer or authorized representative, using training materials and instructions provided by the manufacturer/grantee of the equipment used to encode analog signals
- c. An independent training course (e.g., trade school or technical institution) recognized by the manufacturer/grantee of the equipment used to encode analog signals
- d. In lieu of the preceding training requirements, the operator(s)/maintainer(s) is (are) under the control of a supervisor trained in accordance with above.
(Circle One)

I agree to provide with proper documentation

(Telco's Name)

to demonstrate compliance with the information as provided in the preceding paragraph, if so requested.

(Signature)

(Title)

(Date)

Subscribed and Sworn to before me

this day of 19 .

Notary Public

My Commission expires:

READER SURVEY

Help us to produce a better manual by returning this page with your comments.

Name of Manual _____ Publication No. _____ Issue No. ____

Overall rating of this manual Excellent Good Adequate Poor

Readability of text Very clear Good Adequate Poor

Installation Instructions Very clear Good Adequate Poor

Usefulness of graphics Useful Good Adequate Poor

Is this manual User Friendly? Yes Partly No

Did you find any errors? Yes No

If so, describe (List page No.) _____

Do you recommend additions/changes? Yes No

If so, describe _____

Any additional comments? _____

Name _____ Title _____ Date _____

Company _____ Mail Drop _____

City _____ State _____ ZIP Code or Country _____

Telephone Number if you want us to call you (____) ____ - _____

Copy or remove this page and mail to:

**Publications Department
Technology Center
General DataComm Industries, Inc.
Middlebury, CT 06762-1299**

TABLE OF CONTENTS

Section & Subject	Page
1 — INTRODUCTION	
DataComm 552A-1 V1.1 FEATURES.....	1-1
DESCRIPTION.....	1-2
DIAGNOSTICS.....	1-2
APPLICATIONS.....	1-3
FRACTIONAL T1 CAPABILITIES.....	1-4
SERVICE AND TRAINING.....	1-5
2 — INSTALLATION	
OVERVIEW.....	2-1
UNPACKING AND HANDLING.....	2-1
PREOPERATIONAL CHECK.....	2-1
INSTALLATION PROCEDURES.....	2-1
OPTION SELECTION.....	2-3
Option Switches and Option Selection Diagrams.....	2-4
Channel Flow Control Options.....	2-5
Soft Configuration Privileges Option.....	2-6
Timing Options.....	2-7
ELECTRICAL CONNECTIONS.....	2-20
Channel Port Connection	2-20
Network Port Connection	2-22
Supervisory Port Connection.....	2-24
Primary Power Connection.....	2-27
DataComm Shelf Grounding Jumpers.....	2-28
3 — OPERATION	
OVERVIEW.....	3-1
FRONT PANEL INDICATORS, TEST JACKS, AND SWITCHES.....	3-1
SUPERVISORY TERMINAL OPERATING PROCEDURES.....	3-1
Accessing a DSU.....	3-1
Soft Configuration Privileges Option.....	3-6
The Log-On Screen.....	3-7
Display Information.....	3-8
Using the Keyboard.....	3-8
The Main Menu.....	3-9
Privilege Level.....	3-10
The Modem Session Privileges Screen.....	3-10

INTRODUCTION

TABLE OF CONTENTS (Cont.)

Section & Subject	Page
The Channel Diagnostics Screen.....	3-13
The DS0 Diagnostics Screen	3-15
The T1 Diagnostics Menu.....	3-18
The CSU Configuration Screen.....	3-40
The Channel Configuration Screen.....	3-44
The Maintenance Screen.....	3-50
4 — TESTS	
OVERVIEW.....	4-1
DS1 LOOPBACK FUNCTIONS.....	4-4
DS1 Line Loopback Function.....	4-5
DS1 Network Interface Loopback Function.....	4-6
DS1 Test Loopback Function	4-7
DS1 DIAGNOSTICS.....	4-8
DS1 Line Loop.....	4-8
DS1 Line Loop with Self-Test.....	4-9
DS1 Local Test.....	4-10
DS1 Local Test with Self-Test.....	4-11
DS1 Network Interface Loopback	4-12
DS1 Network Interface Loopback with Self-Test.....	4-13
DS1 Remote Test.....	4-14
DS1 Remote Test with Self-Test.....	4-16
DS1 Self-Test.....	4-18
DS1 Test Loop.....	4-19
DS1 Test Loop with Self-Test	4-20
DS0 DIAGNOSTICS.....	4-21
DS0 Circuit Delay Measurement Test.....	4-21
DS0 Remote Test.....	4-23
DS0 Remote Test with Self-Test.....	4-24
DS0 Self-Test.....	4-25
CHANNEL DIAGNOSTICS.....	4-26
Channel Digital Loop.....	4-26
Channel Local Loop.....	4-28
Channel Remote Digital Loop.....	4-29
Channel Remote Digital Loop with Self-Test.....	4-31
Channel Self-Test.....	4-32
TECHNICAL ASSISTANCE PROCEDURE.....	4-33
TRAINING.....	4-34

TABLE OF CONTENTS (Cont.)

APPENDIX A — TECHNICAL INFORMATION

APPENDIX B — TIMING OPTIONS

APPENDIX C — CONFIGURATION CROSS-REFERENCE

APPENDIX D — GLOSSARY

INDEX

LIST OF ILLUSTRATIONS

Section & Figure	Page
1 — INTRODUCTION	
1-1 TYPICAL NETWORK, LOCAL TERMINAL CONTROL.....	1-8
1-2 TYPICAL NETWORK, REMOTE TERMINAL CONTROL USING MODEMS	1-8
1-3 TYPICAL NETWORK, LOCAL TERMINAL CONTROL USING PMC-100s WITH DIAL BACKUP	1-9
1-4 TYPICAL NETWORK, REMOTE TERMINAL CONTROL USING PMC-100s WITH DIAL BACKUP	1-9
1-5 TYPICAL LARGE NETWORK, REMOTE TERMINAL CONTROL USING MASTER AND SLAVE PMC-100s WITH EXPANSION AND DIAL BACKUP.....	1-10
1-6 TYPICAL HYBRID NETWORK (552A-1 V1.1, 551), REMOTE TERMINAL CONTROL USING PMC-100s WITH EXPANSION AND DIAL BACKUP.....	1-11
1-7 TYPICAL FT1/DDS NETWORK APPLICATION.....	1-12
1-8 TYPICAL CAD/CAM APPLICATION.....	1-12
2 — INSTALLATION	
2-1 OPTION LOCATION AND JUMPER SELECTIONS (2 Sheets).....	2-8
2-2 DataComm ENCLOSURE COVER REMOVAL PROCEDURE.....	2-10
2-3 OPTION SWITCH SELECTIONS (8 Sheets).....	2-11
2-4 POLLING APPLICATION WITH CMI SIGNALLING.....	2-19
2-5 IN-BAND COMMUNICATION PATH.....	2-39
2-6 OUT-OF-BAND COMMUNICATION PATH.....	2-40
2-7 DataComm ENCLOSURE INSTALLATION.....	2-41
2-8 DataComm FOURPAK ENCLOSURE INSTALLATION.....	2-42
2-9 DataComm SHELF INSTALLATION.....	2-43
2-10 GDC TRIPAK SHELF INSTALLATION.....	2-44

INTRODUCTION

LIST OF ILLUSTRATIONS (Cont.)

Section & Figure	Page
2-11 UNIVERSAL SYSTEM SHELF INSTALLATION.....	2-45
2-12 CHANNEL PORT INTERFACE CABLE APPLICATIONS (2 Sheets).....	2-47
2-13 NETWORK PORT INTERFACE CABLE APPLICATIONS.....	2-49
2-14 SUPERVISORY PORT INTERFACE CABLE APPLICATIONS.....	2-50
2-15 SUPERVISORY TERMINAL MODEM APPLICATION.....	2-51
2-16 GROUNDING DataComm SHELF CABLES.....	2-52

3 — OPERATION

3-1 FRONT PANEL INDICATORS.....	3-2
3-2 FRONT PANEL ACCESS TEST JACKS.....	3-3
3-3 FRONT PANEL SWITCHES.....	3-4
3-4 LOG-ON SCREEN.....	3-7
3-5 MAIN MENU.....	3-9
3-6 MODEM SESSION PRIVILEGES SCREEN.....	3-11
3-7 CHANNEL DIAGNOSTICS SCREEN.....	3-13
3-8 DS0 DIAGNOSTICS SCREEN.....	3-15
3-9 T1 DIAGNOSTICS MENU.....	3-18
3-10 ERROR DESCRIPTION.....	3-19
3-11 T1 ALARM HISTORY SCREEN.....	3-20
3-12 TWENTY-FOUR HOUR REPORTS MENU.....	3-24
3-13 LOCAL USER TWENTY-FOUR HOUR REPORT SCREEN PAGES.....	3-25
3-14 LOCAL USER TWENTY-FOUR HOUR REPORT SCREEN (2 Sheets).....	3-27
3-15 REMOTE USER TWENTY-FOUR HOUR REPORT SCREEN (ERRORED SECONDS).....	3-29
3-16 REMOTE NETWORK TWENTY-FOUR HOUR REPORT SCREEN (ERRORED SECONDS).....	3-31
3-17 SCHEDULED PERFORMANCE REPORT SCREEN.....	3-33
3-18 CSU SELF TEST SCREEN.....	3-35
3-19 LOOPBACKS SCREEN.....	3-37
3-20 RECEIVE LEVEL SCREEN.....	3-39
3-21 CSU CONFIGURATION SCREEN.....	3-40
3-22 CHANNEL CONFIGURATION SCREEN.....	3-44
3-23 CHANNEL CONFIGURATION ERROR.....	3-49
3-24 MAINTENANCE SCREEN.....	3-50

4 — TESTS

4-1 TROUBLE DIAGNOSTIC FLOWCHART.....	4-3
4-2 DS1 AND CHANNEL LOOPBACK FUNCTIONS.....	4-4
4-3 DS1 LINE LOOPBACK FUNCTION.....	4-5
4-4 DS1 NETWORK INTERFACE LOOPBACK FUNCTION.....	4-6
4-5 DS1 TEST LOOPBACK FUNCTION.....	4-7
4-6 DS1 LINE LOOP.....	4-8

LIST OF ILLUSTRATIONS (Cont.)

Section & Figure	Page
4-7 DS1 LINE LOOP WITH SELF-TEST	4-9
4-8 DS1 LOCAL TEST.....	4-10
4-9 DS1 LOCAL TEST WITH SELF-TEST	4-11
4-10 DS1 NETWORK INTERFACE LOOPBACK.....	4-12
4-11 DS1 NETWORK INTERFACE LOOPBACK WITH SELF-TEST.....	4-13
4-12 DS1 REMOTE TEST WITH LINE LOOPBACK	4-15
4-13 DS1 REMOTE TEST WITH TEST LOOPBACK.....	4-15
4-14 DS1 REMOTE TEST WITH SELF-TEST AND LINE LOOPBACK.....	4-17
4-15 DS1 REMOTE TEST WITH SELF-TEST AND TEST LOOPBACK.....	4-17
4-16 DS1 END-TO-END SELF-TEST.....	4-18
4-17 DS1 TEST LOOP.....	4-19
4-18 DS1 TEST LOOP WITH SELF-TEST.....	4-20
4-19 DS0 CIRCUIT DELAY MEASUREMENT TEST.....	4-22
4-20 DS0 REMOTE TEST	4-23
4-21 DS0 REMOTE TEST WITH SELF-TEST.....	4-24
4-22 DS0 END-TO-END SELF-TEST.....	4-25
4-23 CHANNEL DIGITAL LOOP.....	4-27
4-24 CHANNEL LOCAL LOOP.....	4-28
4-25 CHANNEL REMOTE DIGITAL LOOP.....	4-30
4-26 CHANNEL REMOTE DIGITAL LOOP WITH SELF-TEST	4-31
4-27 CHANNEL END-TO-END SELF-TEST.....	4-32

LIST OF TABLES

Section & Table	Page
1 — INTRODUCTION	
1-1 HOUSINGS FOR THE 552A-1 V1.1 AND RELATED PRODUCTS.....	1-4
1-2 EQUIPMENT LIST (2 Sheets).....	1-6
2 — INSTALLATION	
2-1 OPTION APPLICATION NOTES (5 Sheets).....	2-29
2-2 DSU ADDRESS SELECTION.....	2-34
2-3 CHANNEL STARTING DS0 NUMBER SELECTION	2-35
2-4 CHANNEL DATA RATE SELECTION.....	2-36

INTRODUCTION

LIST OF TABLES (Cont.)

Section & Table	Page
2-5 CHANNEL FLOW CONTROL LEADS.....	2-37
2-6 CONNECTOR FUNCTION ASSIGNMENTS.....	2-38
2-7 CABLE APPLICATIONS.....	2-46

3 — OPERATION

3-1 MENU ORGANIZATION.....	3-5
3-2 STATUS LINE INDICATORS.....	3-12
3-3 CHANNEL STARTING DS0 AND DATA RATE SELECTION.....	3-46

4 — TESTS

4-1 DS1 LINE LOOP.....	4-8
4-2 DS1 LINE LOOP WITH SELF-TEST	4-9
4-3 DS1 LOCAL TEST.....	4-10
4-4 DS1 LOCAL TEST WITH SELF-TEST	4-11
4-5 DS1 NETWORK INTERFACE LOOPBACK.....	4-12
4-6 DS1 NETWORK INTERFACE LOOPBACK WITH SELF-TEST.....	4-13
4-7 DS1 REMOTE TEST	4-14
4-8 DS1 REMOTE TEST WITH SELF-TEST.....	4-16
4-9 DS1 END-TO-END SELF-TEST.....	4-18
4-10 DS1 TEST LOOP.....	4-19
4-11 DS1 TEST LOOP WITH SELF-TEST.....	4-20
4-12 DS0 CIRCUIT DELAY MEASUREMENT TEST.....	4-21
4-13 DS0 REMOTE TEST	4-23
4-14 DS0 REMOTE TEST WITH SELF-TEST.....	4-24
4-15 DS0 END-TO-END SELF-TEST.....	4-25
4-16 CHANNEL DIGITAL LOOP.....	4-26
4-17 CHANNEL LOCAL LOOP	4-28
4-18 CHANNEL REMOTE DIGITAL LOOP.....	4-29
4-19 CHANNEL REMOTE DIGITAL LOOP WITH SELF-TEST	4-31
4-20 CHANNEL END-TO-END SELF-TEST.....	4-32

SECTION 1

INTRODUCTION

DataComm 552A-1 VERSION 1.1 FEATURES

- Provides an interface to Fractional T1 (FT1) services, giving you the flexibility to utilize only the bandwidth you need, from 56 kbps up to the full T1 rate of 1.536 Mbps
- Allows the linking of FT1 services with traditional Dataphone Digital Service (DDS) and generic digital services, including support for remote digital loopback loop-up/-down codes based on PN-127
- One CCITT V.35-compatible high-speed serial data port (channel) for customer equipment (an EIA-530 compatible channel interface card is available optionally)
- Control Mode Idle (CMI) in-band flow control option for use with 56 kbps DDS I polling applications
- Configurable for network transmitter timing from a variety of sources: provided by an internal clock; provided by the customer channel equipment; or recovered from network data.
- Auto Framing adapts the 552A-1 V1.1 automatically to Extended Superframe Format (ESF) or D4 Superframe Format
- Supports both Alternate Mark Inversion (AMI) and Bipolar with 8 Zero Substitution (B8ZS) line codes, and allows a variety of options for ones density in the data stream
- Supports both PUB 54016 and Bellcore TR-TSY-000194 (ANSI) procedures for the collection and monitoring (via the Supervisory terminal) of the network TABS Maintenance Messages and Performance Report Messages provided by the Central Office, with time-stamped 24-Hour Performance Report statistics stored in non-volatile memory
- Provides two independent register sets for TABS performance data so that the user set is unaffected when the Central Office clears the network set
- DS1-, DS0-, and channel-level diagnostics provide extensive diagnostic capabilities
- Supervisory terminal provides software-control of configuration, diagnostics, and maintenance

INTRODUCTION

- Supports GDC's PMC-100 Performance Monitor Card for enhanced, centralized network control

DESCRIPTION

The 552A-1 Version 1.1 (or V1.1) Data Service Unit (DSU), ideal for medium-sized single-channel networks, provides the interface between the customer's equipment and the Fractional T1 digital carrier facility provided by the Telco or other carrier. The 552A-1 V1.1 provides the DSU function of converting the customer's data stream to bipolar format, and the CSU (Channel Service Unit) functions of network interfacing and protection, as well as a host of other flexible and powerful features, including:

- It can perform automatic line build-out (signal attenuation) of 0, 7.5, or 15 dB at 772 kHz on the network side.
- On detection of an AIS (Alarm Indication Signal), it can automatically terminate a DS1 loopback initiated remotely via in-band codes.
- It can perform a variety of loopbacks and other tests, and allows termination (via the Supervisory terminal) of network-initiated loopbacks.
- It can be configured to limit the configuration changes and diagnostics available via the Supervisory terminal, preventing actions which could disrupt service.

The 552A-1 V1.1 is a dual-card product and can be mounted in the following housings:

- Standalone DataComm Enclosure (model DE-22)
- Four-slot DataComm FourPak Enclosure (model DFP-11)
- Rack-mountable sixteen-slot DataComm Shelf (models DS-1, DS-5R, DS-5NR, DS-6R, and DS-6NR)
- Three-slot GDC TriPak Shelf (models TPS-1 and TPS-2)
- Rack-mountable four-slot Universal System Shelf backplane (models USS-1D, USS-1-DC/R, and USS-1-DC/NR)

(All rack-mountable housings fit into 19- and 23-inch wide equipment racks.)

Table 1-1 lists which related products may be installed with the 552A-1 V1.1 in these housings, depending on slot availability.

DIAGNOSTICS

The 552A-1 V1.1 offers the following DS1-level diagnostics:

- Alarm history display
- ANSI Payload Loopback (PLB)
- Bellcore Performance Report Messages support

- DS1 End-to-End Self-Test
- DS1 Line Loop, with Self-Test
- DS1 Local Test (LT), with Self-Test
- DS1 Network Interface Loopback, with Self-Test
- DS1 Remote Test (RT), with Self-Test
- DS1 Test Loop, with Self-Test
- PUB 54016 DTE Loopback (DLB)
- PUB 54016 TABS Maintenance Message Protocol support

It also offers the following DS0-level diagnostics:

- DS0 Circuit Delay Measurement Test
- DS0 End-to-End Self-Test
- DS0 Remote Test, with Self-Test

The following channel-level (customer equipment) diagnostics are also offered:

- Channel Digital Loop
- Channel Local Loop
- Channel Remote Digital Loop, with Self-Test
- Channel Self-Test (including Channel End-to-End Self-Test)

The 552A-1 V1.1 also allows the user to set the time and date, and display the firmware revision level.

NOTE

Some of these functions require the use of the Supervisory terminal. Refer to Supervisory Terminal Operating Procedures in Section 3 for further discussion.

Part numbers for the 552A-1 V1.1 are listed in Table 1-2.

APPLICATIONS

The 552A-1 V1.1 is used in pairs in a point-to-point data network over a T1 link, with one DSU on each end providing the interface between the customer equipment and the T1 link. One Supervisory terminal is typically co-located with each DSU and used only with that DSU, as shown in Figure 1-1. However, a single Supervisory terminal in a remote service center, for example, can be used to access both DSUs by utilizing modems, as shown in Figure 1-2.

INTRODUCTION

TABLE 1-1. HOUSINGS FOR THE 552A-1 V1.1 AND RELATED PRODUCTS

Product	Housing				
	DE-22	DFP-11	DS-1, -5R, -5NR, -6R/-1, -6NR/-1	TPS-1, -2	USS-1D, -1-DC/R, -1-DC/NR
DataComm 296B Modem					
DataComm 551 CSU					
DataComm 552 DSU					
DataComm 552-1 DSU					
DataComm 552A DSU					
DataComm 552A V1.1 DSU					
DataComm 552A-1 DSU					
DataComm 552A-1 V1.1 DSU					
PMC-100 Performance Monitor Card					

To centralize and enhance network control, install PMC-100 Performance Monitor Cards. The PMC-100s provide Supervisory terminal access to any 552A-1 V1.1 in the network, using a single multiplexer channel on each T1 link for primary intercommunication. And to provide access in the event of a T1 link failure, install modems such as GDC's DataComm 296B Modem for dial backup, as shown in Figure 1-3 (for local access) or Figure 1-4 (for remote access).

Figure 1-5 illustrates a large network with a master and several slave and expansion PMC-100s providing Supervisory terminal access to all sites. Failure of one T1 link does not prevent access to the sites served by it. With one call, the dial backup modems bypass the failed link to fully restore access. Suppose the link between sites A and I fails. This prevents access to site I, as well as sites D, E and F. By establishing a connection via modems at sites A and I, the operator can restore access to these sites and begin troubleshooting the fault. There is normally a modem at each site, but they are not shown in Figure 1-5 for clarity.

Figure 1-6 illustrates a hybrid network utilizing 552A-1 V1.1s for FT1 service and DataComm 551s for T1 service. Figure 1-7 shows how a host/FEP and a 552A-1 V1.1 on an FT1 circuit can be linked to DDS-type DSUs, such as the DataComm 500G/UXR, in a polling application.

The PMC-100 also, on request, polls each 552A-1 V1.1 in the network for its alarm status and displays this on the Supervisory terminal. For other PMC-100 applications in a 552A-1 V1.1 network, and additional PMC-100 information, refer to Publication No. 048R139-000.

FRACTIONAL T1 CAPABILITIES

The 552A-1 V1.1 is equipped with one CCITT V.35-compatible port (channel) for connection to synchronous serial customer equipment such as FEPs, LAN bridges, video codecs, CAD/CAM (illustrated in Figure 1-8), and Group 4 facsimile. This channel is mapped into either consecutive or alternate DS0s in the T1 signal, starting on any DS0 at rates from 56

kbps to 1.536 Mbps (in Nx56 kbps and Nx64 kbps multiples). With consecutive DS0s, the full T1 bandwidth is available but there may be restrictions on ones density, limiting the usable bandwidth. With alternate DS0s, only one-half of the T1 bandwidth is available for customer data, but minimum ones density is maintained at 50% by filling unused DS0s with ones, so there's no restriction on the content of the customer's data.

Available optionally to replace the standard CCITT V.35 channel interface is an EIA-530 compatible interface card.

SERVICE AND TRAINING

Refer to Section 4 for information on service and training available from GDC.

INTRODUCTION

TABLE 1-2. EQUIPMENT LIST

Description	GDC Part No.
DataComm 552A-1 V1.1 DSU, standalone enclosure (model DE-22 base), 117 V ac, one V.35 channel interface	048A070-101
DataComm 552A-1 V1.1 DSU, standalone enclosure (model DE-22 base), 117 V ac, one EIA-530 channel interface	048A070-111
DataComm 552A-1 V1.1 DSU, rackmount pc card, one V.35 channel interface	048M070-101
DataComm 552A-1 V1.1 DSU, rackmount pc card, one EIA-530 channel interface	048M070-111
EIA-530 Channel Interface Card	048P042-001
Shorting jumper, 2x8 pin (for use when EIA-530 Channel Interface Card is not installed; four required)	208-011-716
PMC-100 Performance Monitor Card	048P038-001
Optional Mounting Enclosures and Shelves	
DataComm FourPak Enclosure model DFP-11, standalone, 117 V ac	010B115-001
DataComm Shelf, rackmount	
Model DS-1, 117 V ac	010B015-001
Model DS-5R, dc-powered with redundant power supplies	010M011-001
Model DS-5NR, dc-powered with non-redundant power supply	010M011-002
Model DS-6R, dc-powered with redundant power supplies, with Telco, VF and DTE cables	010M047-001
Model DS-6NR, dc-powered with non-redundant power supplies, with Telco, VF and DTE cables	010M047-002
Model DS-6R-1, dc-powered with redundant power supplies, with Telco and VF cables only	010M047-003
Model DS-6NR-1, dc-powered with non-redundant power supplies, with Telco and DTE cables only	010M047-004
GDC TriPak Shelf, rackmount	
Model TPS-1, 117 V ac	010B124-001
Model TPS-2, 48 V dc	010B125-001
Universal System Shelf, rackmount	
Model USS-1D, 117 V ac	010B080-001
Model USS-1-DC/R, dc-powered with redundant power supplies	010M040-002
Model USS-1-DC/NR, dc-powered with non-redundant power supply	010M040-001
Domestic DataComm Backplane (for Universal System Shelf installation)	048B015-001
Optional Equipment	
Supervisory terminal (customer-provided)	n/a
Modem (customer-provided)	n/a
Applicable Instruction Manuals	
Instruction Manual for GDC TriPak Shelf	010R355-000
Instruction Manual for 10-1/2 Inch DataComm Shelf (Model DS-1)	010R310-000
Instruction Manual for DataComm 10 1/2-Inch DC-to-DC Shelf Model DS-5	010R340-000
Instruction Manual for DataComm 10 1/2-Inch DC-to-DC Shelf Model DS-6	010R341-000
Instruction Manual for Universal System Shelf Models USS-1D, -1E, -1J, -1U, -1H	010R380-000
Instruction Manual for Universal System Shelf DC-to-DC Models USS-1-DC/NR, -DC/R	010R385-000
Operating and Installation Instructions for PMC-100 Performance Monitor Card	048R139-000
DataComm/NMS DSU Data Rate Adapter Card Addendum	048R161-A1

TABLE 1-2. EQUIPMENT LIST (Cont.)

Description	GDC Part No.
Cables	
Customer Equipment Cables	
Adapter cable, 34-pin female to 25-pin male (use with cable P/N 027H516-XXX for a CCITT V.35 channel port in any housing except a DataComm Enclosure model DE-22; included with models with a V.35 interface)	027H560-001
Adapter cable, 37-pin female to 25-pin male (use with customer-provided cable for RS-449 channel equipment in any housing with an EIA-530 Channel Interface Card)	027H501-001
Grounding jumper for customer equipment cables (required for a DataComm shelf housing only; one included with each rackmount 552A-1 V1.1 pc card)	024H005-X03
Interface cable, CCITT V.35 34-pin male-to-male (DSU channel port to customer equipment) (5- to 50-foot lengths)	027H516-XXX
Interface cable, EIA/TIA-232-E/EIA-530 25-pin female-to-male (DSU channel port to customer equipment with a male connector; DSU Supervisory port to a terminal or multiplexer channel with a female connector) (26- and 43-inch, and 2- to 100-foot lengths)	028H511-XXX
Interface cable, EIA/TIA-232-E/EIA-530 25-pin male-to-male (DSU channel port to customer equipment with a female connector) (6-, 26- and 43-inch, and 2- to 100-foot lengths)	028H502-XXX
Interface cable, RS-422 25-pin male-to-male (DSU channel port to multiplexer aggregate) (5- to 50-foot lengths)	027H531-XXX
Interface cable, RS-449 37-pin male to 25-pin male (DSU channel port to customer equipment with a female RS-449 connector) (5- to 25-foot lengths)	023H603-XXX
Front Panel Cables	
Bantam-to-WECO 310 Adapter Plug	209-026-S001
Front panel access test jack patch cable (male-to-male) (24- and 60-inch lengths)	830-005-XXX
Front panel access test jack patch cable Bantam-to-WECO 310 (4 feet)	830-021-S001
Network Cables	
Interface cable, RJ48C plug to 15-pin female (DSU network port to the T1 line, for Canadian installation only) (10- to 125-foot lengths)	022H020-XXX
Interface cable, RJ48C plug-to-plug (DSU network port to the T1 line for any housing; 022H024-010 included with standalone enclosure models) (10- to 50-foot lengths)	022H024-XXX
Interface cable, RJ48C plug-to-terminal lugs (DSU network port to the T1 line for any housing except a DataComm Shelf) (10- to 50-foot lengths)	022H021-XXX
Network Cables (DataComm Shelf only)	
Adapter cable, RJ48C plug-to-plug (DSU network port to the T1 line for a DataComm Shelf housing only; use with coupler 209-038-002)	027H242-X04
Coupler, RJ48C jack-to-jack (use with adapter cable 027H242-X04)	209-038-002
Interface cable, RJ48C plug-to-terminal lugs (DSU network port to the T1 line for a DataComm Shelf housing only) (10- to 50-foot lengths)	022H025-XXX
Supervisory Terminal Cables	
Interface cable, EIA/TIA-232-E 25-pin female-to-male (DSU Supervisory port to a modem) (1- to 50-foot lengths)	028H311-XXX
Interface cable, EIA/TIA-232-E/EIA-530 25-pin female-to-female (DSU Supervisory port to a terminal or multiplexer channel with a male connector) (1- to 25-foot lengths)	028H507-XXX
Interface cable, EIA/TIA-232-E/EIA-530 25-pin female-to-male (DSU Supervisory port to a terminal or multiplexer channel with a female connector; DSU channel port to customer equipment with a male connector) (26- and 43-inch, and 2- to 100-foot lengths)	028H511-XXX

INTRODUCTION

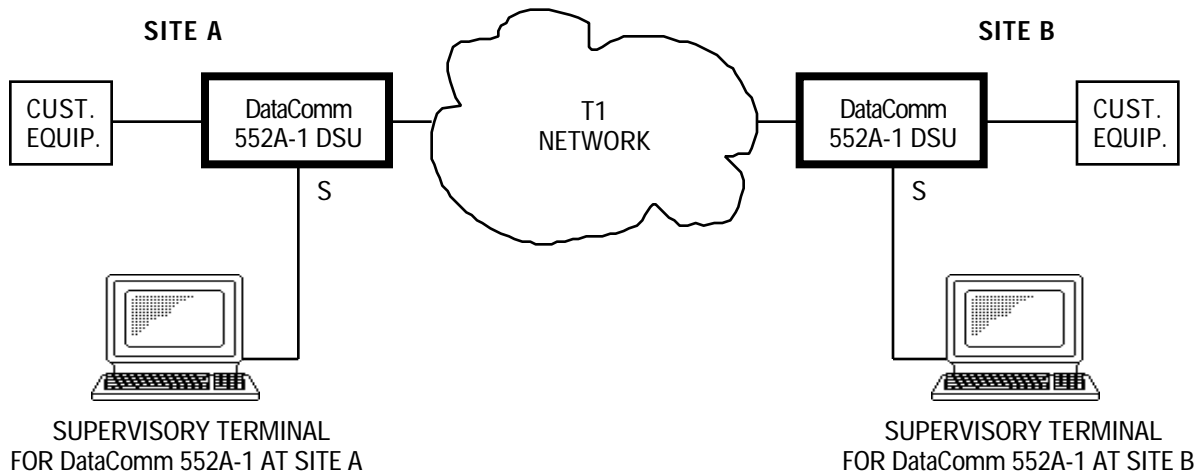

FIGURE 1-1. TYPICAL NETWORK, LOCAL TERMINAL CONTROL

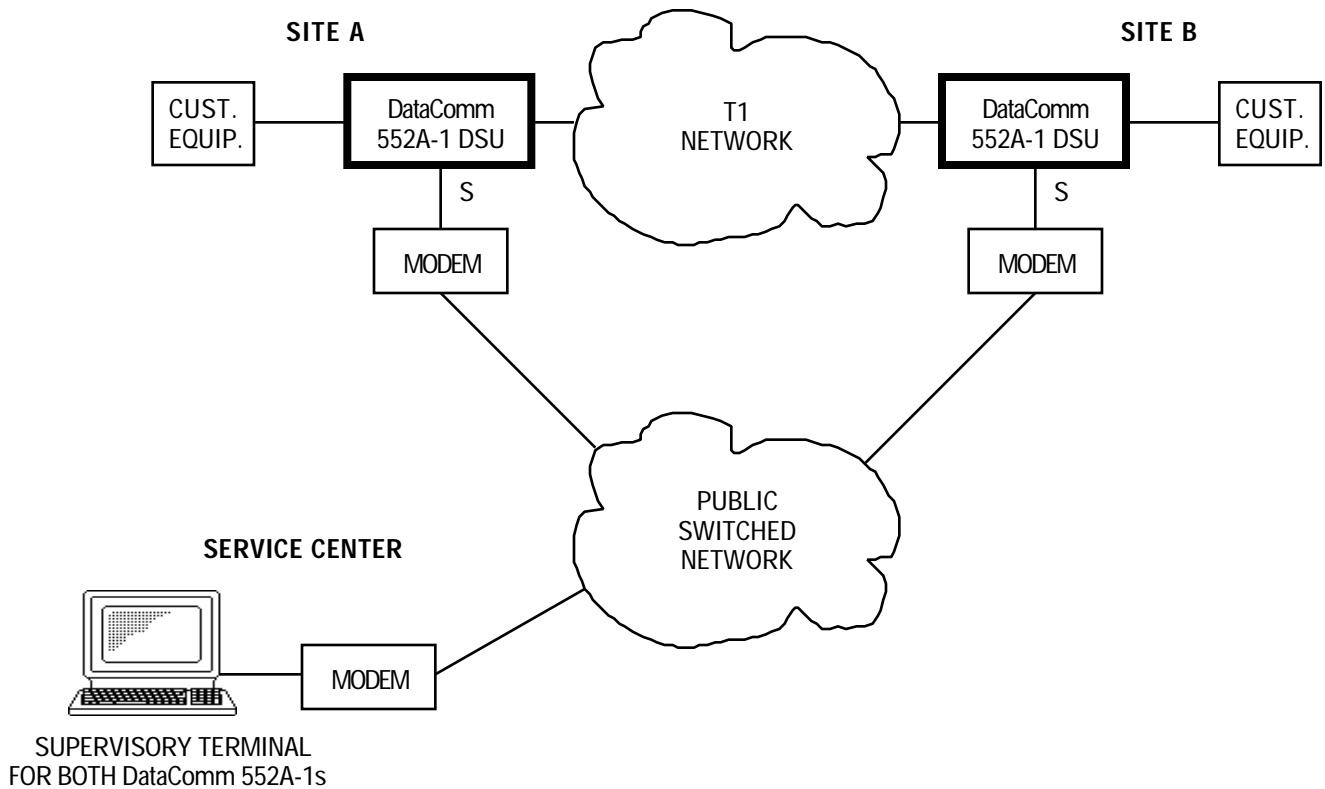

FIGURE 1-2. TYPICAL NETWORK, REMOTE TERMINAL CONTROL USING MODEMS

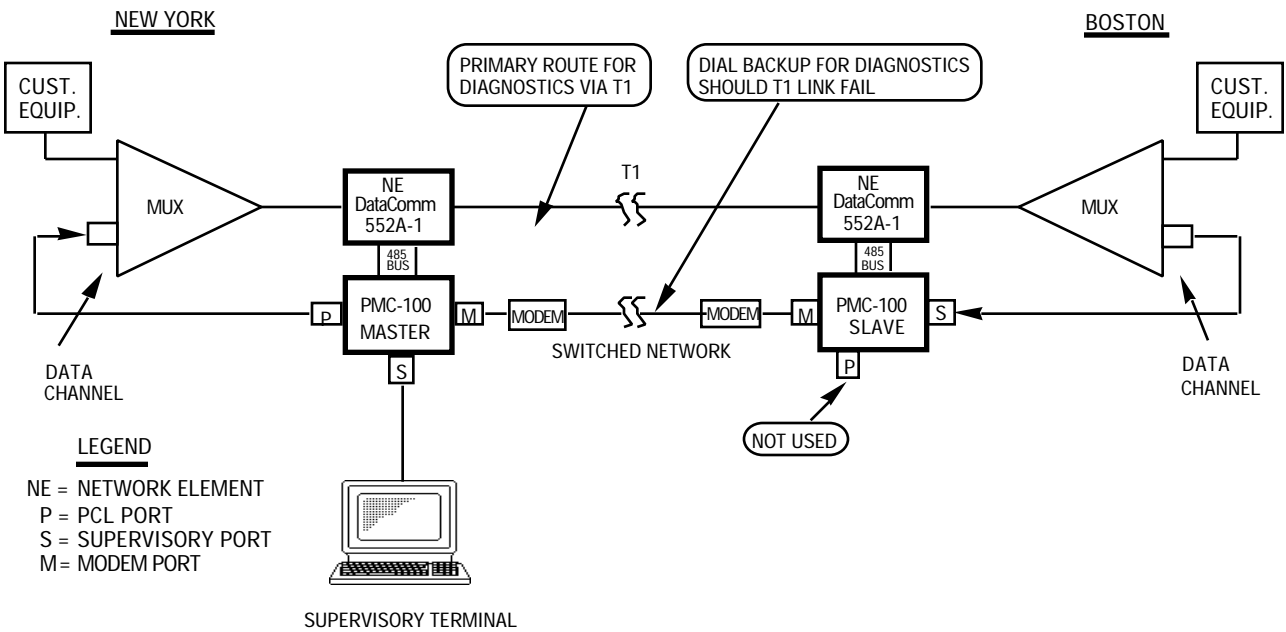

FIGURE 1-3. TYPICAL NETWORK, LOCAL TERMINAL CONTROL USING PMC-100s WITH DIAL BACKUP

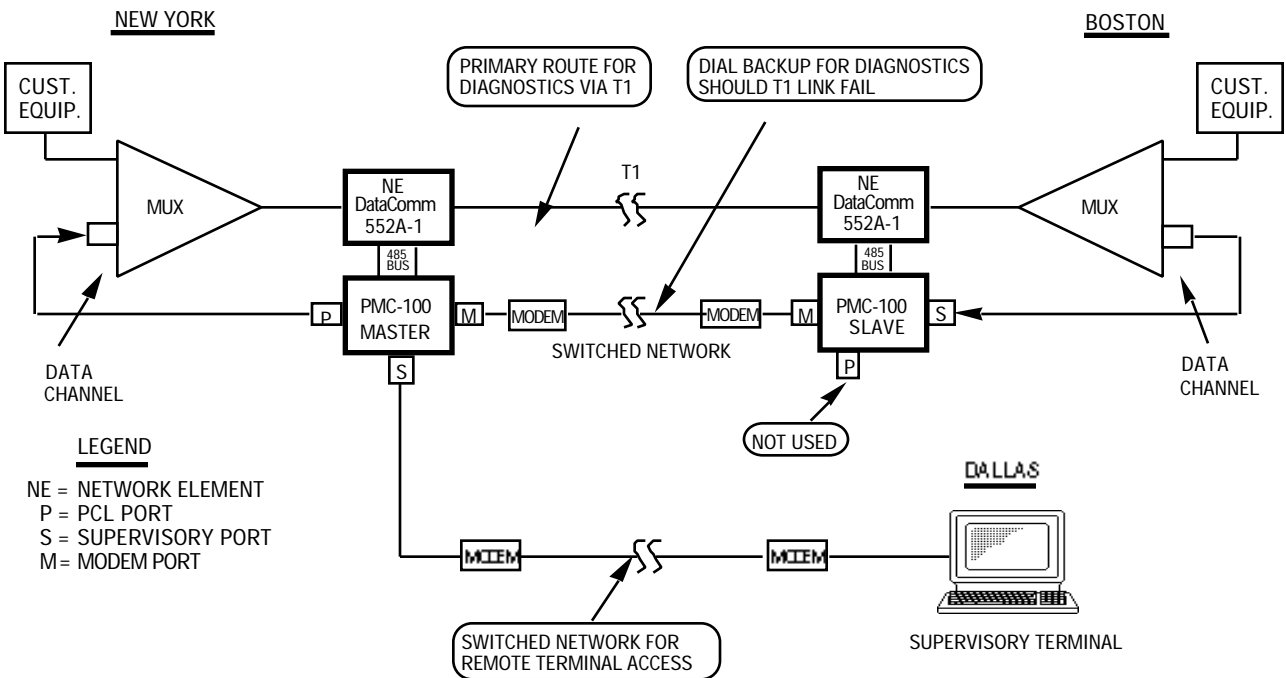

FIGURE 1-4. TYPICAL NETWORK, REMOTE TERMINAL CONTROL USING PMC-100s WITH DIAL BACKUP

INTRODUCTION

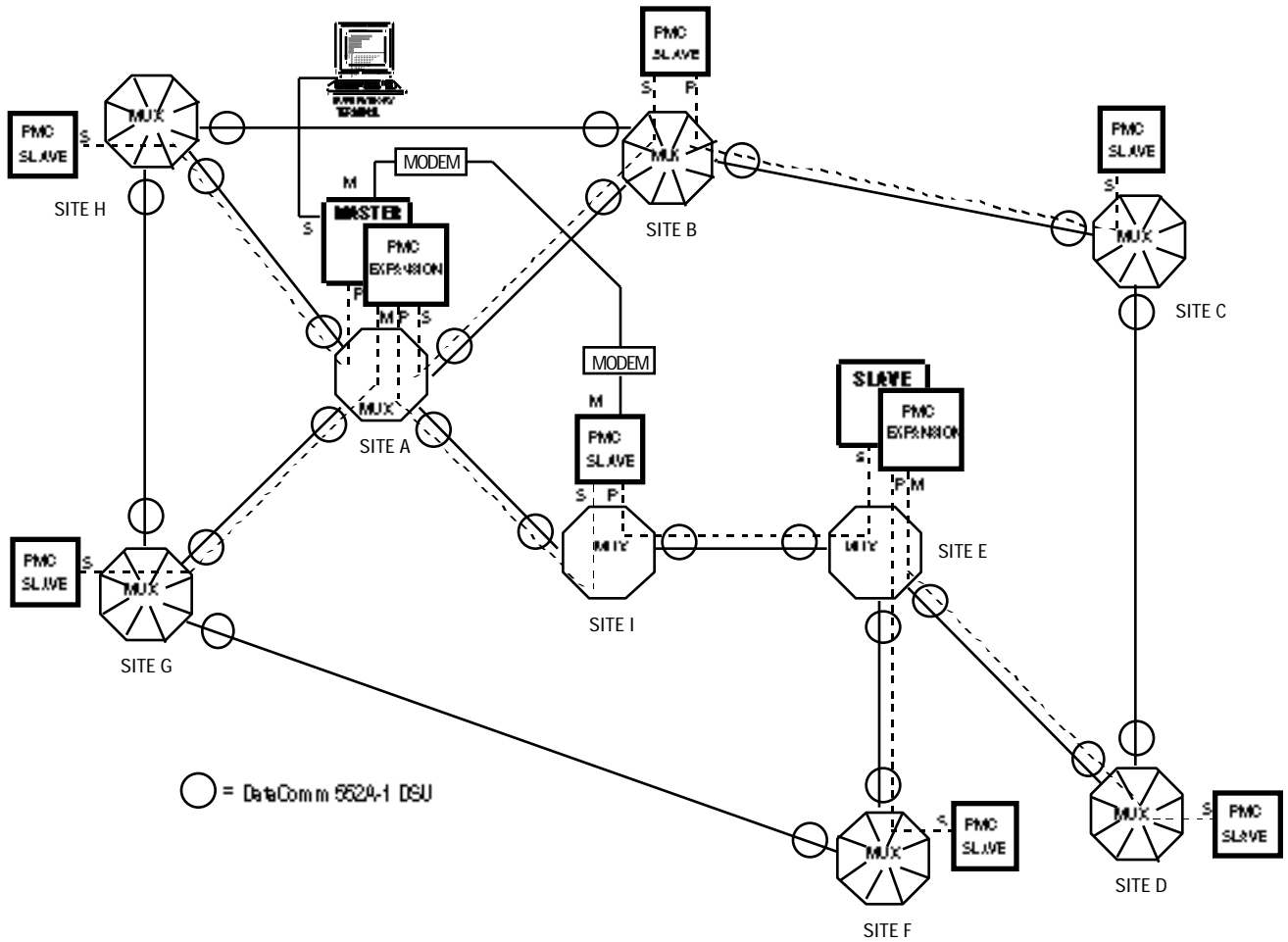

FIGURE 1-5. TYPICAL LARGE NETWORK, REMOTE TERMINAL CONTROL USING MASTER AND SLAVE PMC-100s WITH EXPANSION AND DIAL BACKUP

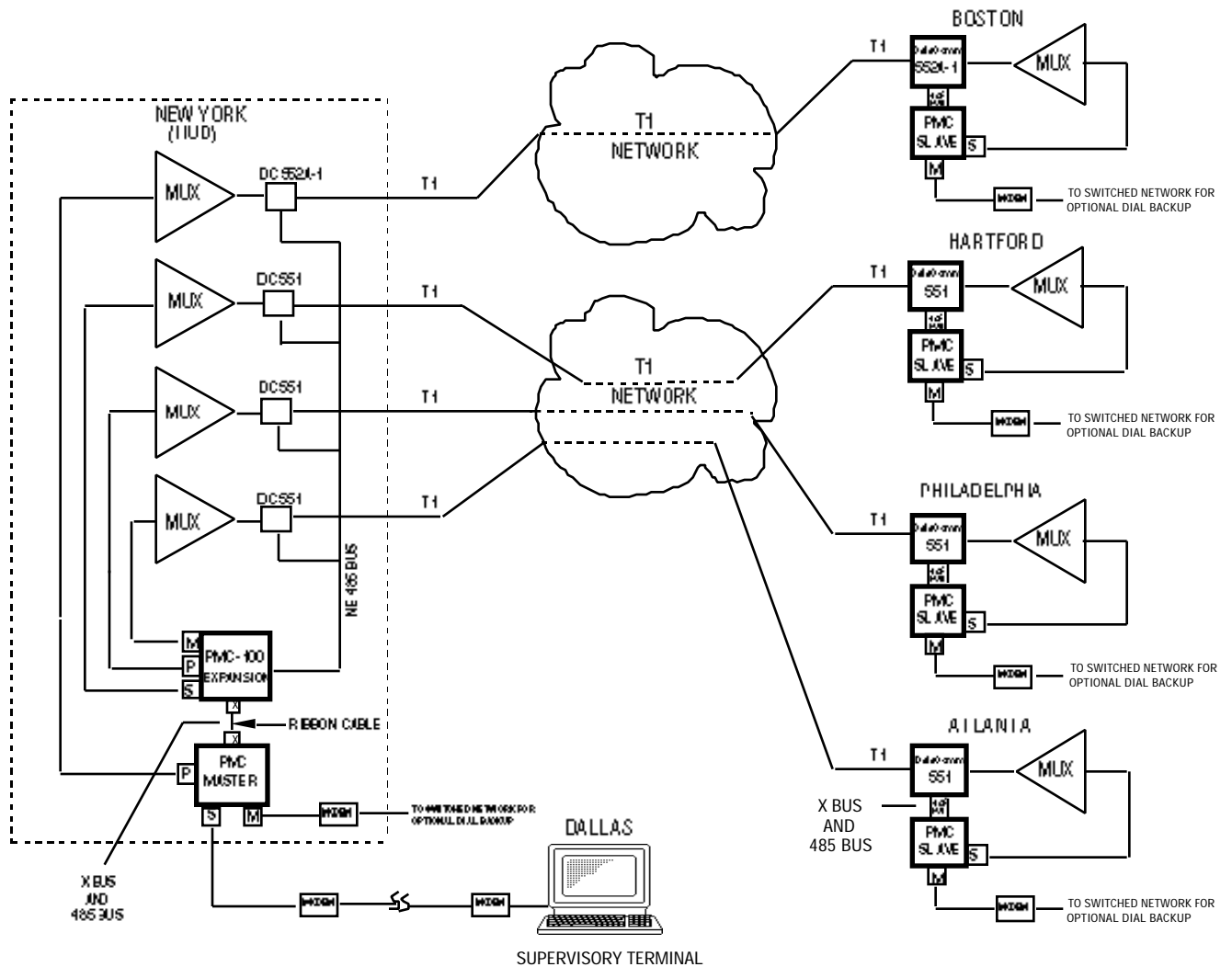

FIGURE 1-6. TYPICAL HYBRID NETWORK (552A-1 V1.1, 551), REMOTE TERMINAL CONTROL USING PMC-100s WITH EXPANSION AND DIAL BACKUP

INTRODUCTION

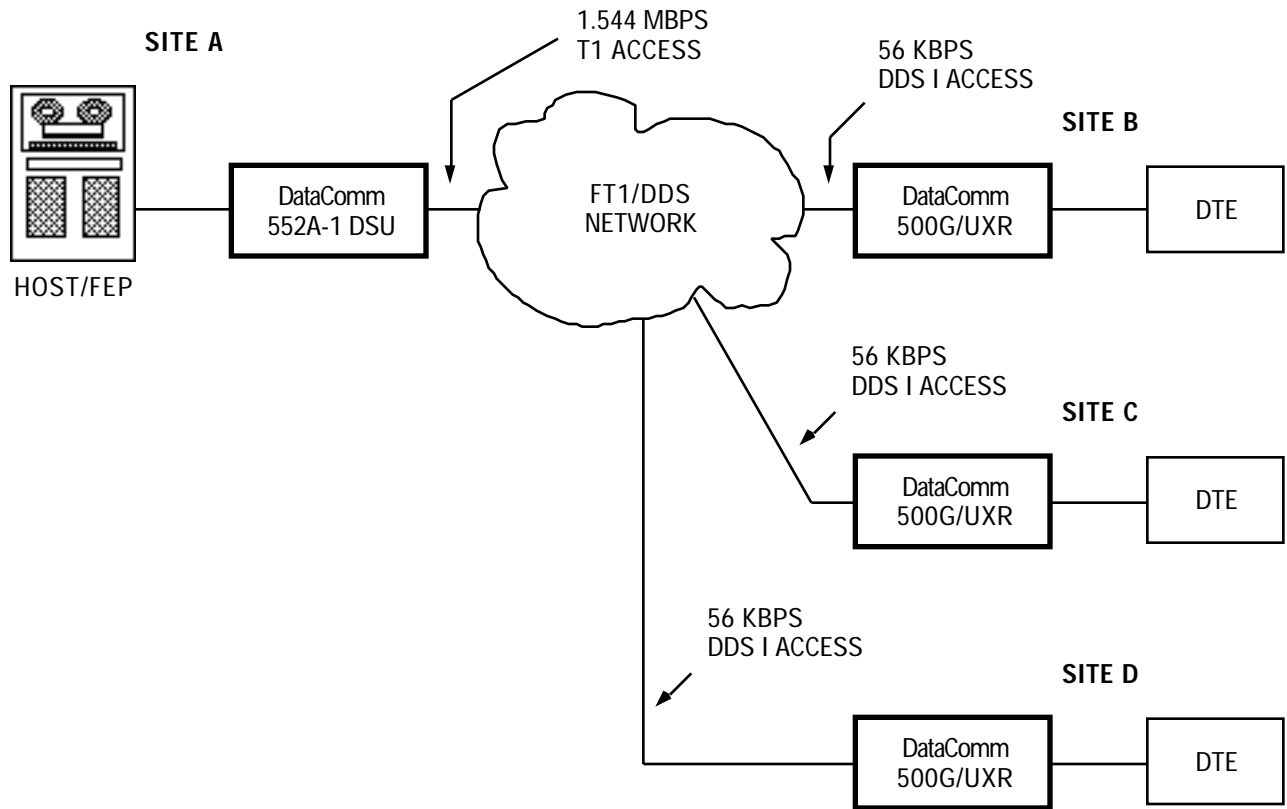

FIGURE 1-7. TYPICAL FT1/DDS NETWORK APPLICATION

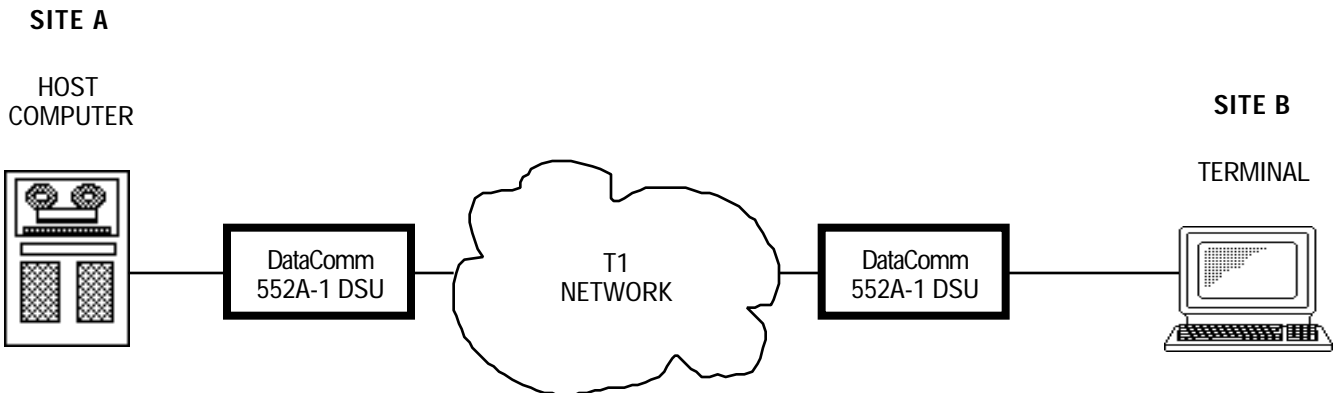

FIGURE 1-8. TYPICAL CAD/CAM APPLICATION

SECTION 2

INSTALLATION

OVERVIEW

This section describes the installation of the DataComm 552A-1 V1.1, including option selection.

UNPACKING AND HANDLING

The unit is shipped in packing material that is enclosed in a corrugated box. Inspect the unit for damage; if any is observed, notify the shipper immediately. Do not discard the box and packing material; their use will facilitate reshipping the unit, if necessary.

PREOPERATIONAL CHECK

Before it is connected to the network or the customer equipment, and *before any factory-set options are changed*, the DSU should be given a preoperational check by performing a DS1 Local Test with Self-Test to verify normal operation. Refer to Section 4 for instructions on performing this test. First verify that the options are set as shown in Figure 2-1, and perform the test on the DSU before it is connected to anything except ac power.

If the DSU passes the test, but subsequently fails to perform in data communications operation, it may not be at fault; some error may have been made in the installation or option selection, or there are other faulty devices or connections. Recheck the connections and option selections, and if necessary perform the Fault Isolation Procedures in Section 4 to isolate the fault. Also verify that the customer equipment and remote DSU are compatible. In the event that the DSU does not check out properly, replace it with a spare, if available, and repeat the test. Do not attempt to repair the DSU. For assistance, contact DataComm Service Corporation (refer to the Technical Assistance Procedure in Section 4).

INSTALLATION PROCEDURES

The DSU should be installed in a ventilated area where the ambient temperature does not exceed 122°F (50°C). Do not install the DSU above other equipment that generates large amounts of heat (e.g., power supplies).

You can mount the DSU in the following housings:

INSTALLATION

DataComm Enclosure (model DE-22)

You can mount one DSU in a standalone DataComm Enclosure.

If it is necessary to remove the pc cards from the enclosure:

1. Disconnect ac power by pulling the ac plug from the wall receptacle.
2. Disconnect phone connections.

WARNING

Disconnect power supply (or cable) and communications line (T1 line) connections prior to removal of the cover.

3. Remove the cover, as shown in Figure 2-2.
4. Disconnect the power supply connector from J5, which is mounted at the rear center of the lower card (see Figure 2-1).

When reinstalling the pc cards, reinstall the power supply connector at J5 before replacing the ac plug into the wall receptacle.

DataComm FourPak Enclosure (model DFP-11)

You can mount two DSUs or a combination of one DSU and other plug-ins (PMC-100 Performance Monitor Cards, DataComm 551 CSUs, and DataComm 296B Modems only) in a standalone DataComm FourPak Enclosure. If it is necessary to remove the pc cards from the enclosure, use the procedure for the DataComm Enclosure.

DataComm Shelf (models DS-1, DS-5R, DS-5NR, DS-6R/-1, and DS-6NR/-1)

You can mount up to 8 DSUs or a combination of DSUs and other plug-ins (including DataComm 551 CSUs and DataComm 296B Modems) in a rack-mountable DataComm Shelf. A DSU can be installed in any slot pair; however, for each DSU, one adapter cable and coupler (P/Ns 027H242-X04 and 209-038-002) are required to connect the T1 line.

NOTE

When you install a DSU in a DataComm Shelf, you must ground the customer equipment cables, as described under Electrical Connections.

When you install the DataComm 552A-1 V1.1 in any dc powered DataComm shelf, you should select "OPEN" for the ground option (jumper X1). For shelf grounding follow the guidelines in the shelf manual, or observe telco/Bellcore practices, whichever is applicable.

GDC TriPak Shelf (models TPS-1 and TPS-2)

You can mount one DSU or a combination of one DSU and another plug-in (including DataComm 551 CSUs and DataComm 296B Modems) in a rack-mountable GDC TriPak Shelf.

Universal System Shelf (models USS-1D, USS-1-DC/R, and USS-1-DC/NR)

You can mount up to 8 DSUs or a combination of DSUs and other plug-ins (including PMC-100 Performance Monitor Cards, DataComm 551 CSUs, and DataComm 296B Modems) in a rack-mountable Universal System Shelf. For each group of two DSUs, one Domestic DataComm Backplane (P/N 048B015-001) must be installed, occupying four slots (one quadrant) in the shelf.

All rack-mountable housings fit into 19- and 23-inch wide equipment racks.

Instructions specific to installing the DSU in the above housings follow. Refer to the appropriate Instruction Manual for general installation instructions.

OPTION SELECTION

The field-selectable options adapt the DSU to a variety of configurations, as well as enable or disable certain features and tests. These options are selected by the positioning of switches and jumper straps on the pc cards (hard configuration). Some of these options may also be selected via the Supervisory terminal (soft configuration, described under Supervisory Terminal Operating Procedures in Section 3), and stored in non-volatile memory, overriding the switch settings. Before selecting any options, consult Tables 2-1 through 2-4 to determine which options should be selected for your application. For a complete cross-reference of the DSU's hard- and soft-configurable options, refer to Appendix C.

CAUTION

- a. *Do not enable Auto Framing for both DSUs on a link.*
- b. *If you connect two DSUs back-to-back (a direct cable connection), do not enable automatic Network Line Build-Out for both of them.*

NOTE

- a. *When you are using PMC-100s to provide network control, you must select a unique network address, and enable PMC-100 Operation, for each DSU in the network.*
- b. *When connected to a DS1 Interface Connector (or Smart Jack), the DSU must be configured for manual Network Line Build-Out (consult the carrier for the proper attenuation level).*

After determining which options should be selected, see Figure 2-3 (which describes the method of implementing each option) and Figure 2-1 (which illustrates the location of each switch and jumper, and its default setting). Also refer to Section 3, which describes configuring the DSU via the Supervisory terminal.

NOTE

Several options are discussed in detail in the following paragraphs. All remaining options are discussed briefly in Table 2-1 and Figure 2-3, and those selectable via the Supervisory terminal are discussed in detail in Section 3 under The CSU Configuration Screen and The Channel Configuration Screen.

Option Switches and Option Selection Diagrams

The DSU uses two basic types of option switches: piano switches and slide (or rocker) switches. The CSU-function card (the lower card) usually uses piano switches that are easily accessible from the side. To select an option parameter with a piano switch, flip the switch up (away from the pc card) to turn the switch OFF, or flip the switch down (toward from the pc card) to turn the switch ON. The DSU-function card (the upper card) usually uses slide (or rocker) switches. To select an option parameter with a slide (rocker) switch, slide (rock) the switch to the left to turn the switch OFF, or slide (rock) the switch to the right to turn the switch ON.

Figure 2-3 (eight sheets, usually one sheet per switch) describes *how to set the switches* to select specific option parameters (option selection details are included in Table 2-1). The instructions are brief, yet the figures provide a lot of information. Starting from the left side of the page:

- Option name
In uppercase bold letters (applicable notes are in parentheses).
- Pc card silkscreen name
Located to the left of each switch position, written exactly as printed on the pc card.
- Switch position number
1, 2, 3, etc. (each switch typically has eight positions). If an option uses two or more switch positions, they are grouped with a dotted line.
- Site switch setting
A space (box) for each switch position, for you to permanently record the switch setting for your site configuration (write in OFF or ON, up or down, or use arrows).
- Default setting
Located to the right of each switch position, showing the factory default setting (OFF or ON).
- Option parameter choices and selection
Located on the right side of the page, each choice (in italics) is followed by the required switch setting. The default choice is listed first.

- General description
 Located at the bottom of the page, includes the switch number, which pc card it is on, the basic options supported, and a reminder on switch settings.

Channel Flow Control Options

The channel flow control options determine the behavior of several of the channel interface control leads. The options are DSR Operation, CTS Operation, and CMI Signalling.

DSR AND CTS OPERATION OPTIONS

These options, which determine the behavior of the Data Set Ready (DSR) and Clear to Send (CTS) leads, are selected with option switches S12-6 and S12-8.

DSR Operation Option

DSR can respond normally or it can be forced ON (default). Normal DSR operation means that the DSU turns it OFF to indicate it is in a diagnostic mode or in an error condition, or turns it ON to indicate it is ready.

CTS Operation Option

CTS can respond normally (default) or it can be forced ON. Normal CTS operation means that the DSU turns it ON 10 milliseconds after sensing that the customer channel equipment has turned ON Request To Send (RTS).

NOTE

Refer to Table 2-5 for detailed information on how these leads behave when the DSU is in a diagnostic mode or in an error condition.

CMI SIGNALLING OPTION

Control Mode Idle (CMI) uses in-band signalling to convey carrier control information end-to-end. It is used in polling applications on 56 kbps DDS I lines, as illustrated in Figure 2-4, with remote DSUs such as GDC's DataComm 500G/UXR. The CMI Signalling option, selected with option switch S12-7, uses the following handshaking protocol:

1. While the host is idle, it keeps RTS OFF. This causes each remote DSU to keep its DCD OFF.
2. When the host needs to poll remote DTE, it turns ON RTS. After a delay, the local DSU turns ON CTS.
3. When the remote DSUs detect this, they turn ON DCD.
4. The host sends the address of the remote DTE it is polling. When the addressed remote DTE detects its address, it turns ON RTS. After a delay, the remote DSU turns ON CTS.

INSTALLATION

5. When the local DSU detects this, it turns ON DCD. The local and addressed remote DTE now have a full-duplex communication path.
6. When the session is complete, the hosts turns OFF RTS.
7. When the remote DSU detects this, it turns OFF DCD. All equipment is now in the idle state, waiting for the host to begin another session.

NOTE

- a. *This option is available only when the DS0 Type option is Nx56 kbps.*
- b. *CMI is compatible only with FT1 lines using Nx56 kbps DS0s, and full-rate 56 kbps DDS I lines. Do not use it with a sub-rate or DDS II (Secondary Channel) line.*

Soft Configuration Privileges Option

The Soft Configuration Privileges option (selected with option switch S4-6) provides control over using the Supervisory terminal to configure the DSU and to perform diagnostics. A DSU with Full Control privileges (sometimes called a master DSU) allows unrestricted configuration and diagnostics via the Supervisory terminal, while a DSU with Monitor privileges (sometimes called a slave DSU) gives the user the ability to separately control these privileges (depending on the Supervisory terminal communication path). There are two means of communication between the Supervisory terminal and a DSU's Supervisory port:

- ***In-band communication*** — the primary means of communicating with the DSU, utilizing PMC-100s and a dedicated multiplexer channel (i.e., a permanent virtual circuit, or PVC). In-band communication is intended for monitoring the DSU's performance reports and performing other **non-disruptive** diagnostics and maintenance functions. A DSU configured for Monitor privileges, when accessed via in-band communication, restricts Supervisory privileges to monitor only, preventing configuration changes and diagnostics. A typical in-band communication path is illustrated in Figure 2-5.

NOTE

When you are using PMC-100s to provide network control, you must select a unique network address, and enable PMC-100 Operation, for each DSU in the network.

- ***Out-of-band communication*** — the alternate means of communicating with the DSU, that does not depend on the T1 link to the DSU. Out-of-band communication with the DSU is typically made via modems or a Supervisory terminal co-located with the DSU. It is intended for performing diagnostics that would disrupt in-band communication (such as a loopback) and for accessing the DSU when a T1 link failure prevents in-band communication. A DSU configured for Monitor privileges, when accessed via out-of-band communication, gives the user the

ability to separately control Supervisory configuration and diagnostics privileges. A typical out-of-band communication path is illustrated in Figure 2-6.

Refer to Electrical Connections for additional installation information, and to Supervisory Terminal Operating Procedures in Section 3 for operation and configuration procedures.

Timing Options

The timing options determine the clock sources for the data the DSU transmits to the network and receives from the customer channel equipment. The default timing option for the DSU is Slave Timing and is used when the network provides the timing source. When provided (as in a DACS-based system), the network's clock must be used. However, the DSU allows other timing options for use in applications where a network clock is not available. The flexibility and complexity of the DSU's timing options require explanations that are more detailed than those normally provided. Refer to Appendix B for details and applications of the DSU's timing options.

INSTALLATION

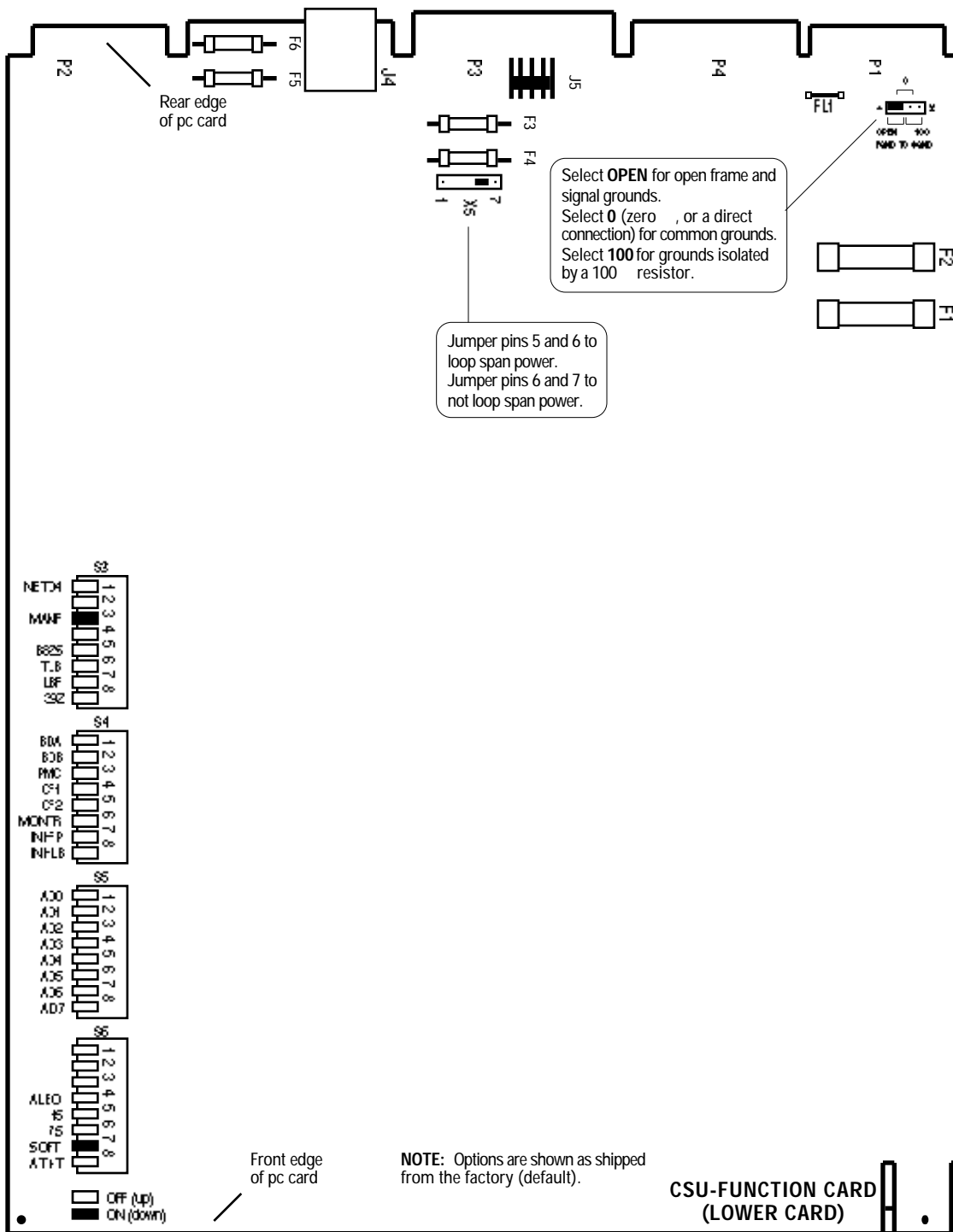

FIGURE 2-1. OPTION LOCATION AND JUMPER SELECTIONS (Sheet 1 of 2)

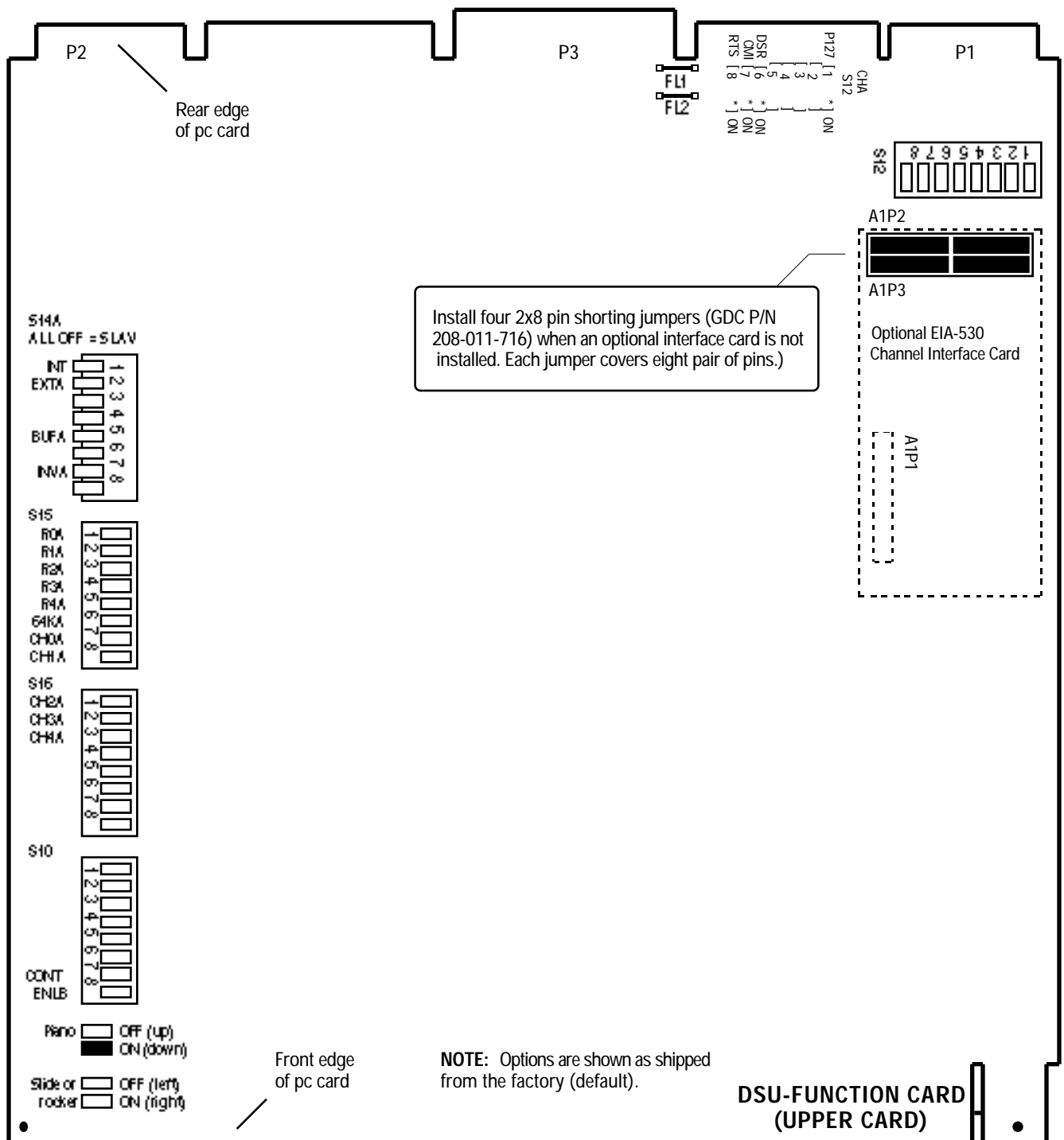

FIGURE 2-1. OPTION LOCATION AND JUMPER SELECTIONS (Sheet 2 of 2)

INSTALLATION

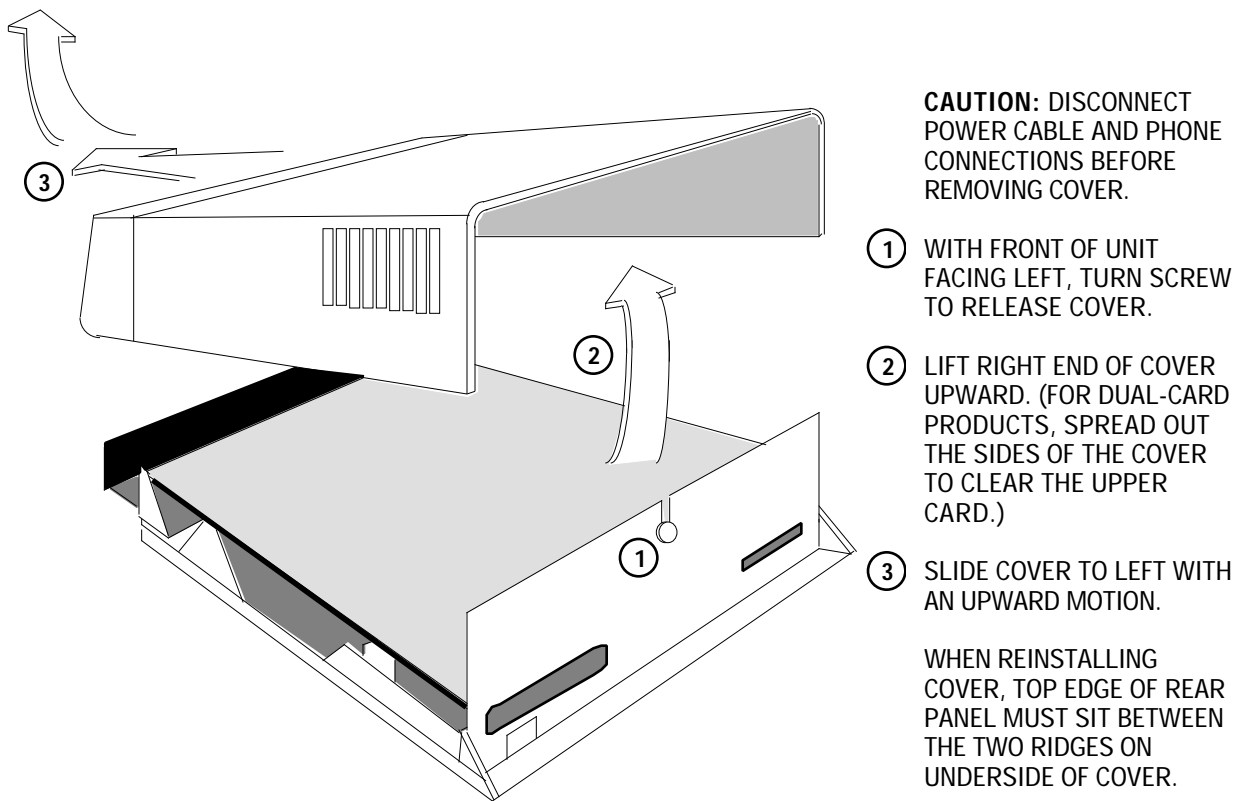
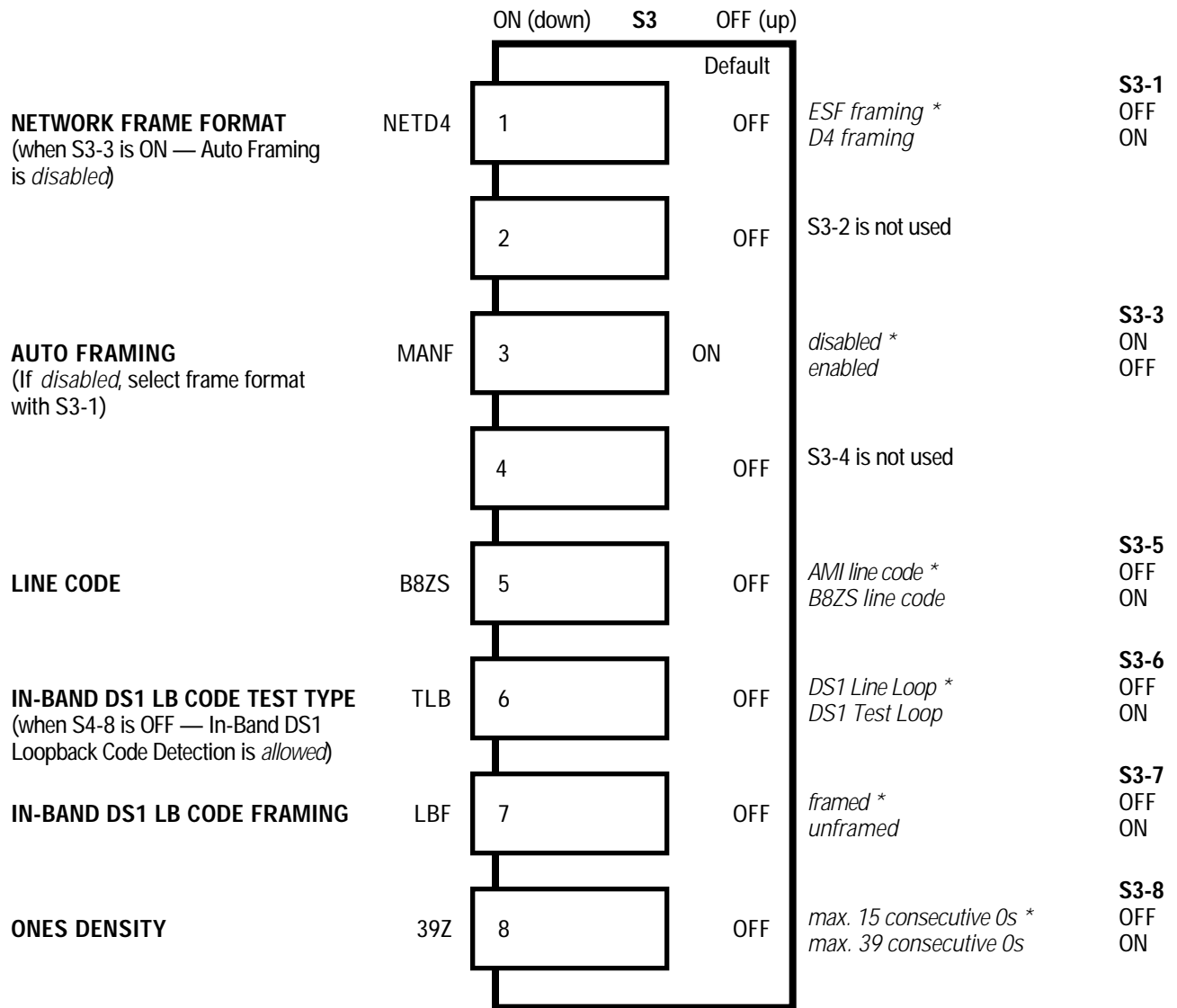

FIGURE 2-2. DataComm ENCLOSURE COVER REMOVAL PROCEDURE



Option Switch S3 on CSU-Function Card

Network Port Options

Piano Switch - Top View

Switch OFF is away from the pc card (up)

Switch ON is toward the pc card (down)

* Factory default position

FIGURE 2-3. OPTION SWITCH SELECTIONS (Sheet 1 of 8)

INSTALLATION

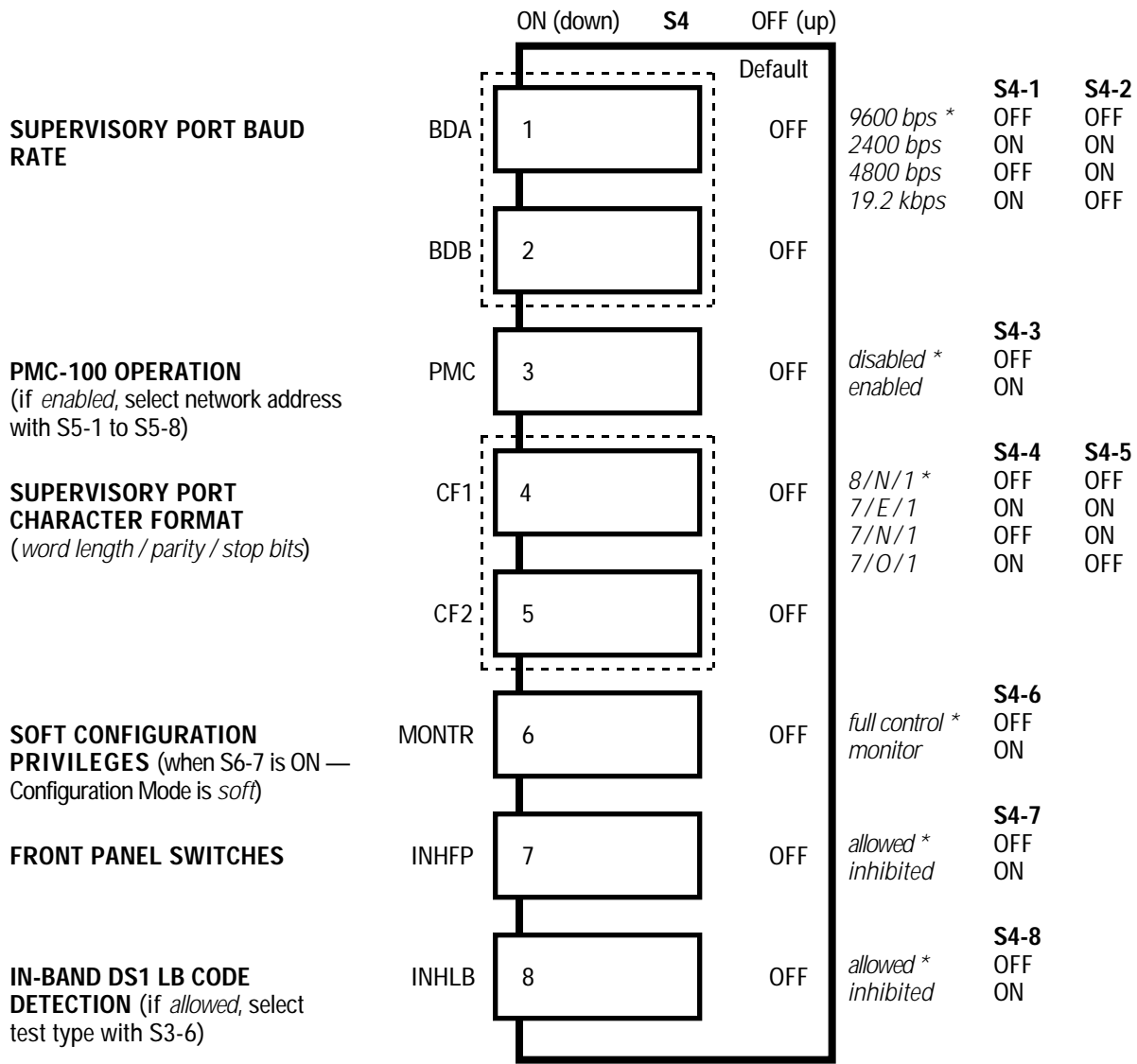

Option Switch S4 on CSU-Function Card

Supervisory Port, PMC-100, Front Panel, and Diagnostics Options

Piano Switch - Top View

Switch OFF is away from the pc card (up)

Switch ON is toward the pc card (down)

* Factory default position

FIGURE 2-3. OPTION SWITCH SELECTIONS (Sheet 2 of 8)

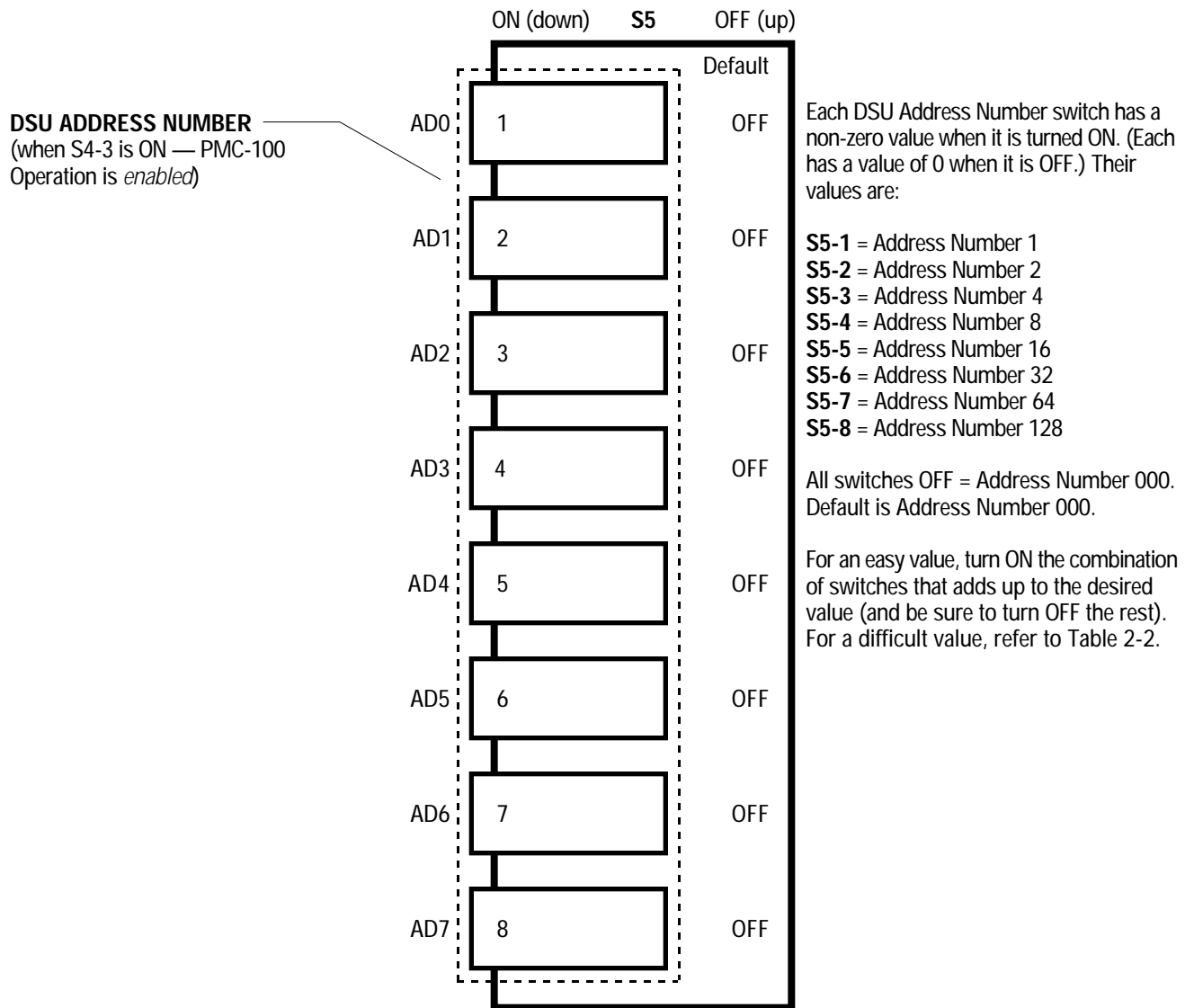

Option Switch S5 on CSU-Function Card

DSU Address Number Option

Piano Switch - Top View

Switch OFF is away from the pc card (up)

Switch ON is toward the pc card (down)

* Factory default position

FIGURE 2-3. OPTION SWITCH SELECTIONS (Sheet 3 of 8)

INSTALLATION

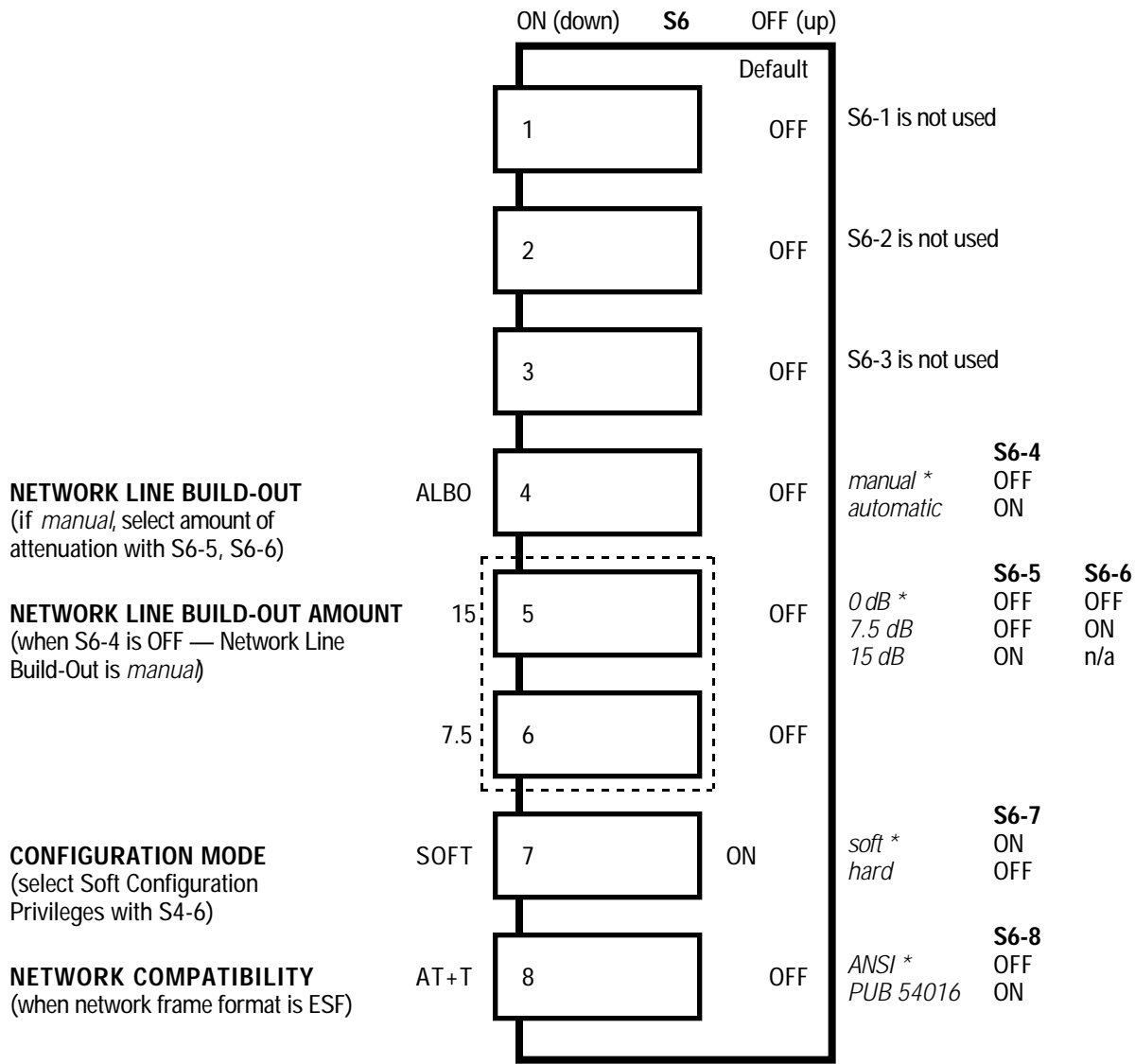

NETWORK LINE BUILD-OUT
(if *manual*, select amount of attenuation with S6-5, S6-6)

NETWORK LINE BUILD-OUT AMOUNT
(when S6-4 is OFF — Network Line Build-Out is *manual*)

CONFIGURATION MODE
(select Soft Configuration Privileges with S4-6)

NETWORK COMPATIBILITY
(when network frame format is ESF)

Option Switch S6 on CSU-Function Card

Network and Configuration Mode Options

Piano Switch - Top View

Switch OFF is away from the pc card (up)

Switch ON is toward the pc card (down)

* Factory default position

FIGURE 2-3. OPTION SWITCH SELECTIONS (Sheet 4 of 8)

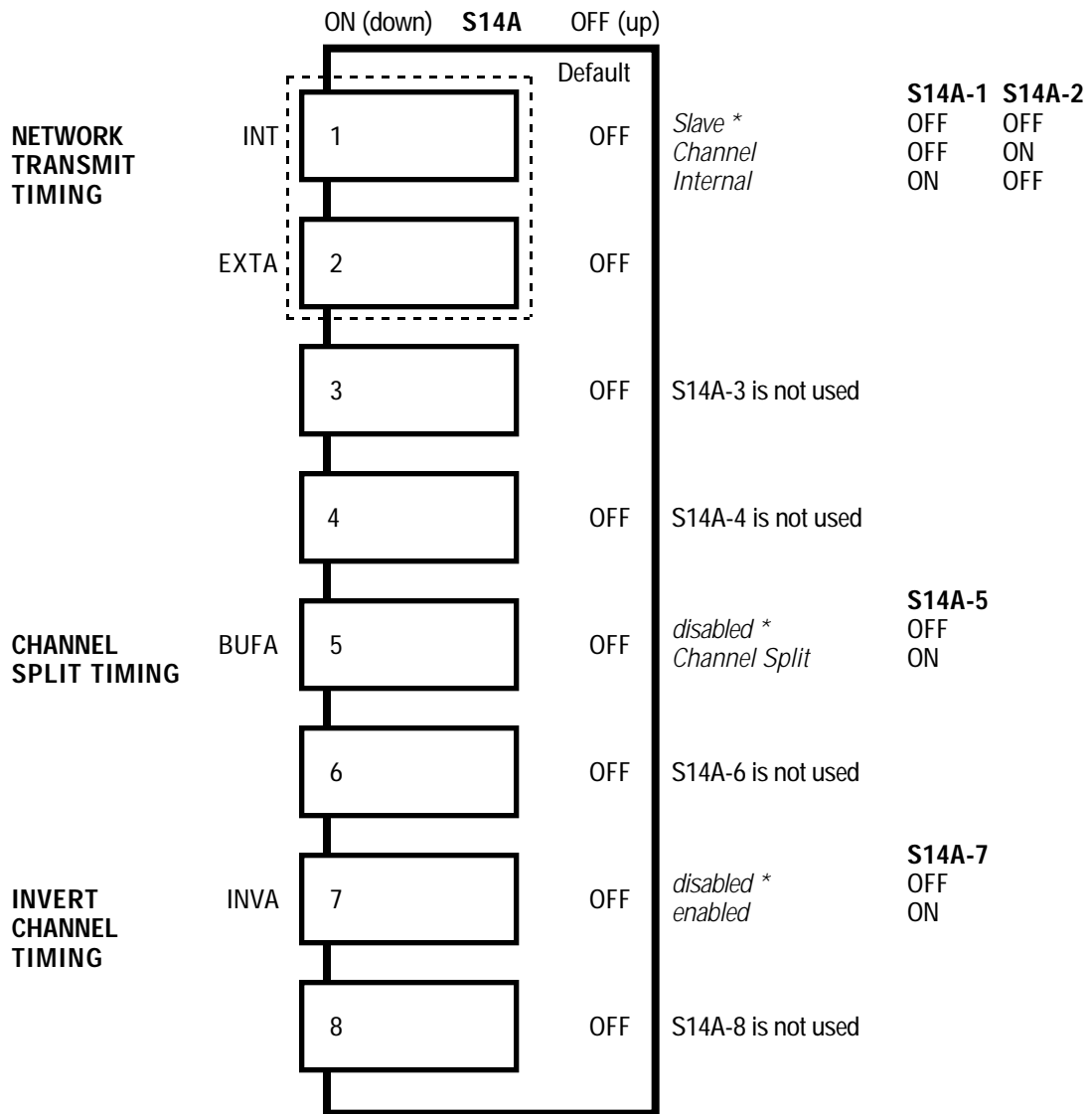

Option Switch S14A on DSU-Function Card

Timing Options

Piano Switch - Top View

Switch OFF is away from the pc card (up)

Switch ON is toward the pc card (down)

* Factory default position

FIGURE 2-3. OPTION SWITCH SELECTIONS (Sheet 5 of 8)

INSTALLATION

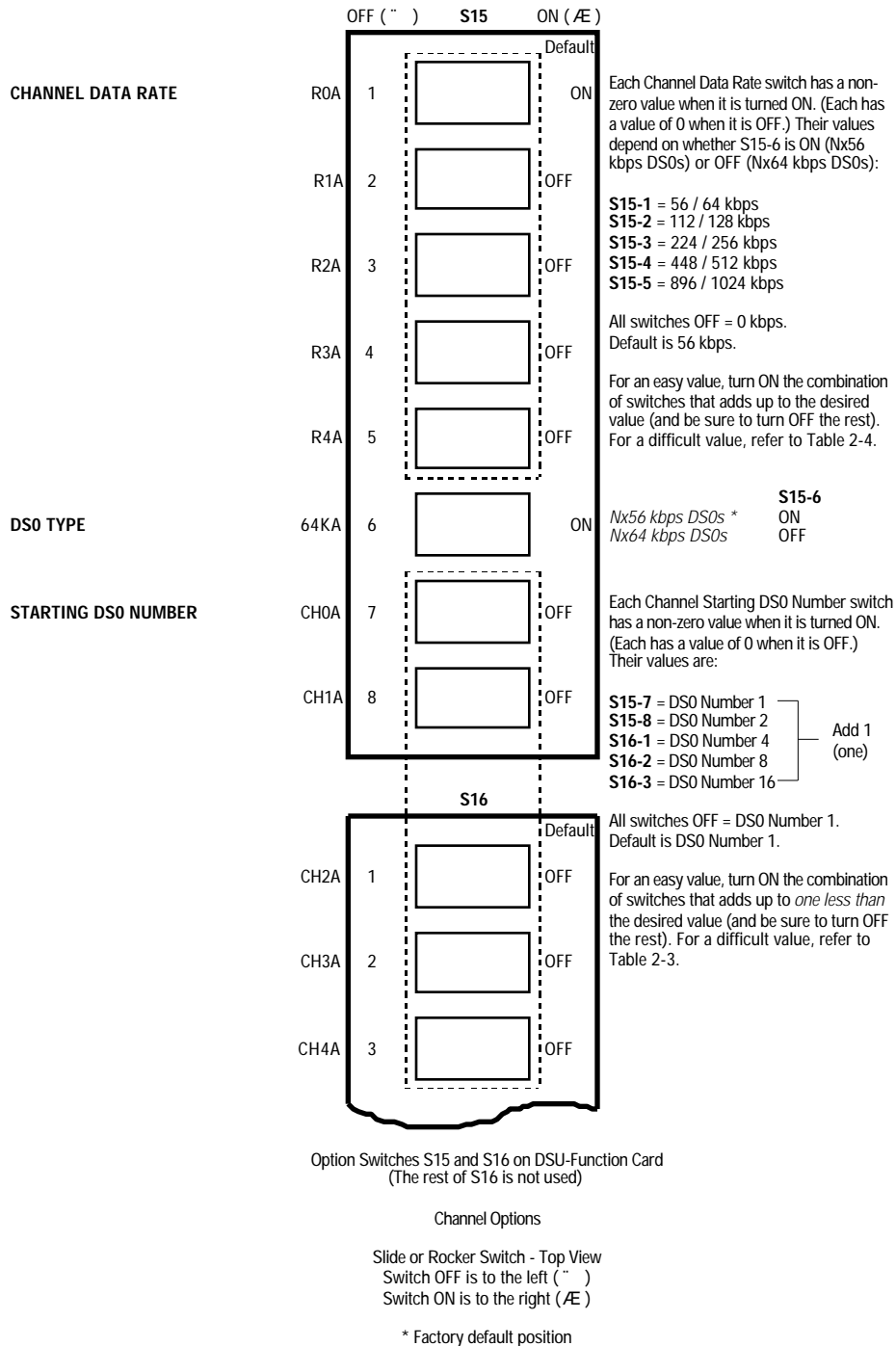
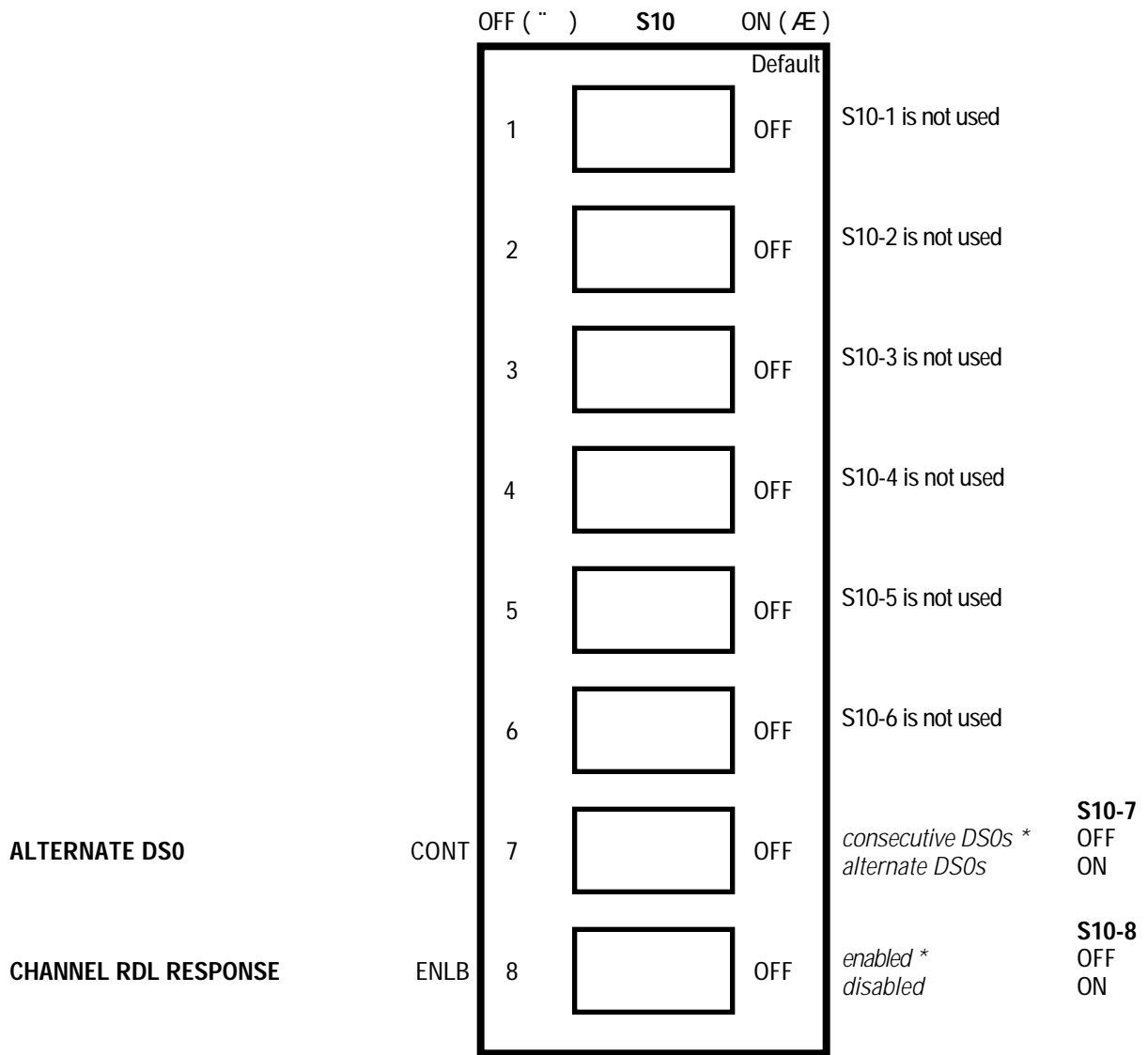

FIGURE 2-3. OPTION SWITCH SELECTIONS (Sheet 6 of 8)



Option Switch S10 on DSU-Function Card

Alternate DS0 and Channel RDL Response Options

Slide or Rocker Switch - Top View
 Switch OFF is to the left (")
 Switch ON is to the right (Æ)

* Factory default position

FIGURE 2-3. OPTION SWITCH SELECTIONS (Sheet 7 of 8)

INSTALLATION

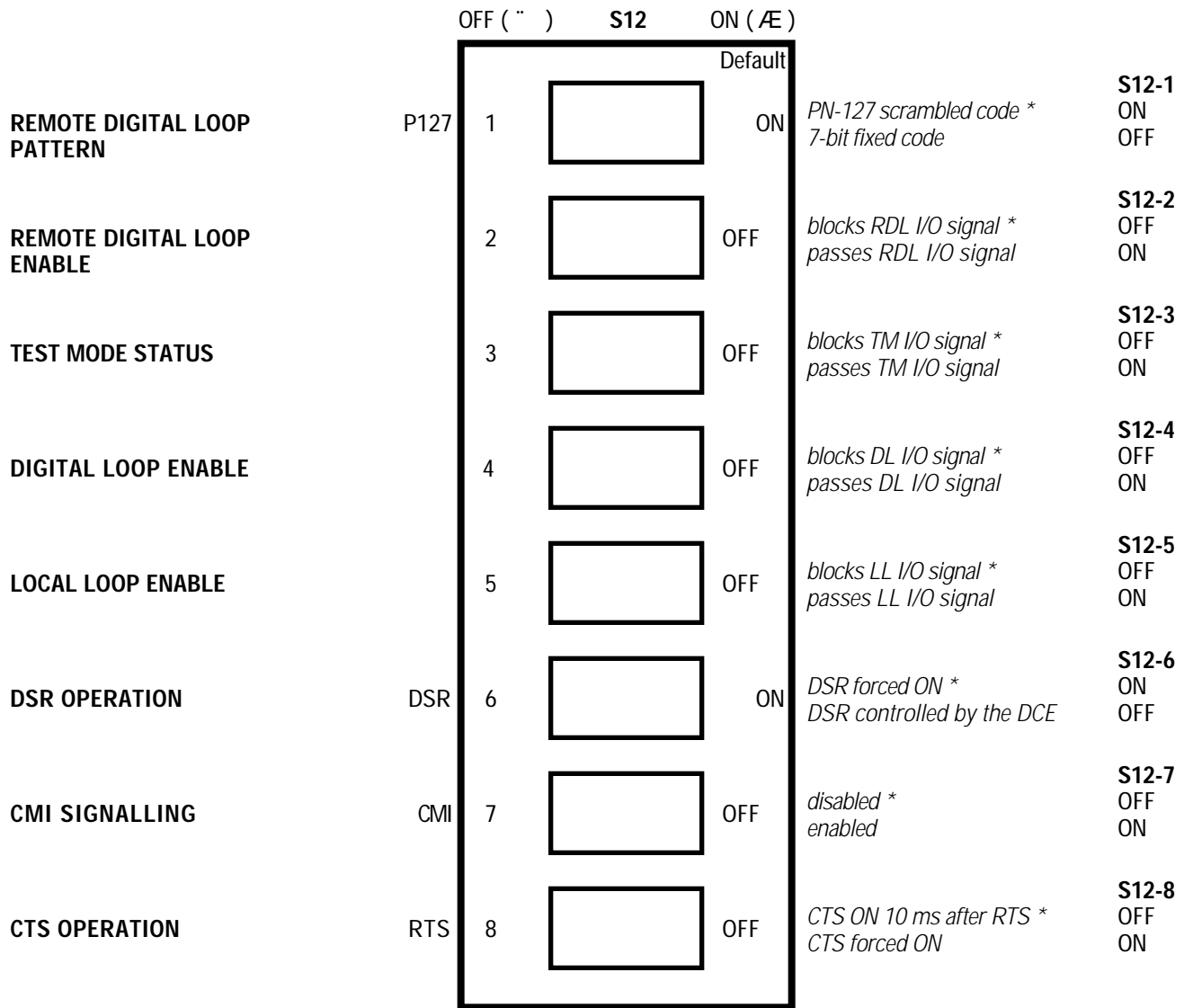

Option Switch S12 on DSU-Function Card

Channel Options

Slide or Rocker Switch - Top View

Switch OFF is to the left (")

Switch ON is to the right (Æ)

* Factory default position

FIGURE 2-3. OPTION SWITCH SELECTIONS (Sheet 8 of 8)

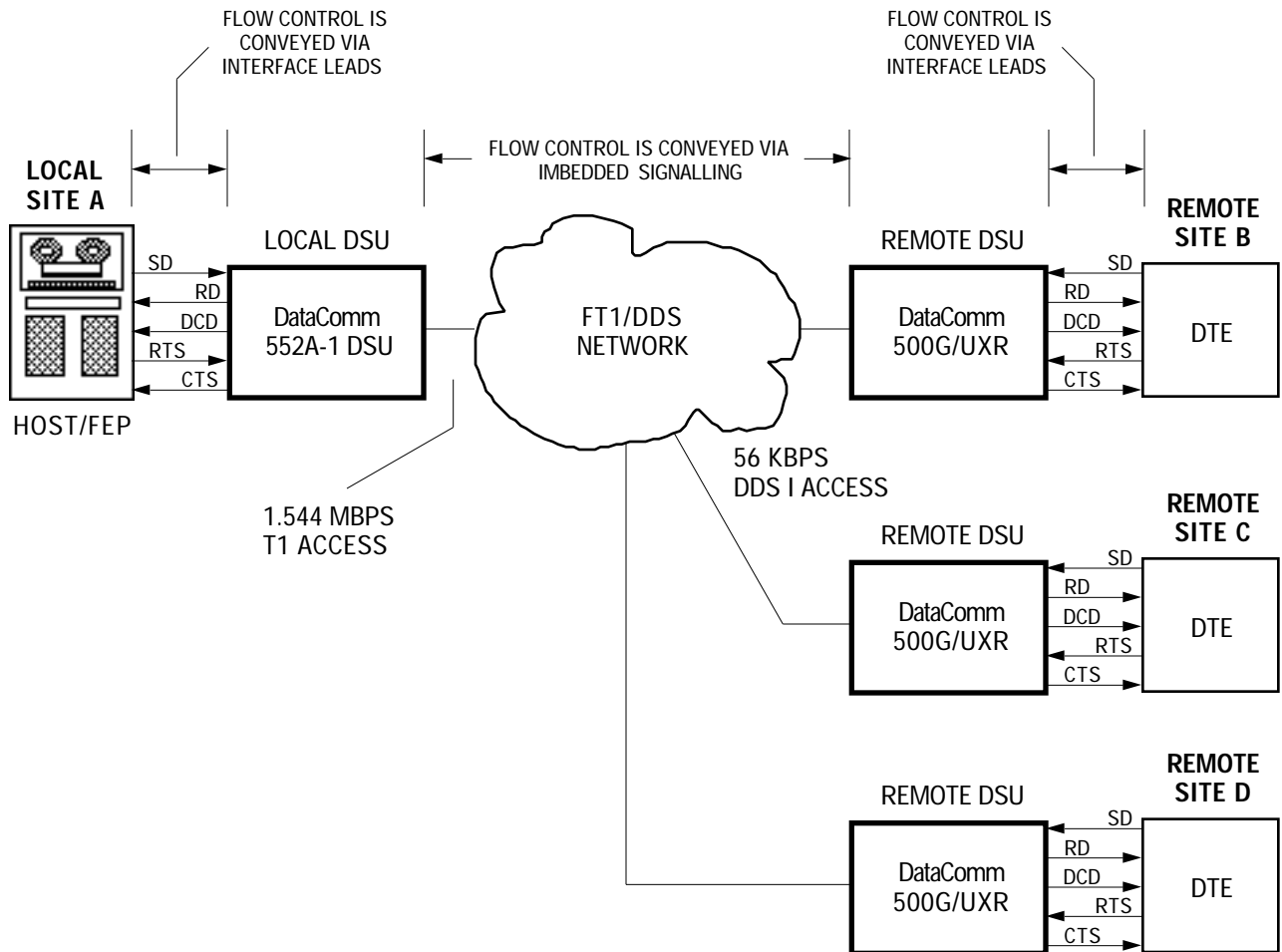

FIGURE 2-4. POLLING APPLICATION WITH CMI SIGNALLING

INSTALLATION

ELECTRICAL CONNECTIONS

The following paragraphs describe the channel port, network port, Supervisory port, and primary power connections to the DSU. The DSU is a dual-card product and can be installed in any two adjacent slots. Table 2-6 lists the connector function assignment and labeling for each port in each housing, and Figures 2-7 through 2-11 show the locations of these connectors for each housing. Table 2-7 and Figures 2-12 through 2-14 show the various cables available and their application.

NOTE

For Canadian installations only, a special cable is required for the network port connection. Use GDC cable P/N 022H020-XXX (RJ48C plug to 15-pin female) to connect the network port to the T1 line.

Channel Port Connection

There is one channel port for connection of customer equipment. Connect the customer equipment to the DSU as described below.

NOTE

When an optional interface card is not installed, you must install shorting jumpers (GDC P/N 208-011-716) on connectors A1P2 and A1P3, as shown in Figure 2-1, Sheet 2.

Unless otherwise noted, the channel port interface is a 25-pin female subminiature-D (DB25S) connector located on the rear panel. Refer to Table 2-7 and Figure 2-12 for the appropriate interface cable. Depending on the type of interface installed, the DSU requires that the signals be connected to the pins as follows:

<u>CCITT V.35 (standard interface)</u>			
<u>34-Pin Pin No.</u>	<u>25-Pin Pin No.</u>	<u>Function</u>	<u>Direction</u>
A	1	Frame Ground, AA	n/a
P	2	Send Data (a), BA	To DSU
S	14	Send Data (b), BA	To DSU
R	3	Rcv Data (a), BB	From DSU
T	16	Rcv Data (b), BB	From DSU
C	4	RTS, CA	To DSU
D	5	CTS, CB	From DSU
E	6	DSR, CC	From DSU
B	7	Sig Gnd, AB	n/a
F	8	DCD, CF	From DSU
CC	11	DL to Remote	To DSU
U	12	Ext Clk (a), DA	To DSU
W	24	Ext Clk (b), DA	To DSU
V	13	Rcv Clk (a), DD	From DSU
X	17	Rcv Clk (b), DD	From DSU
Y	19	Tx Clk (a), DB	From DSU
AA	15	Tx Clk (b), DB	From DSU
H	20	DTR, CD	To DSU
BB	21	RDL, RL	To DSU
K	25	Test Mode, TM	From DSU
L	18	Local Loop, LL	To DSU

EIA-530 (optional interface; use EIA-530 Card)

<u>Pin No.</u>	<u>Function</u>	<u>Direction</u>
1	Frame Ground, AA	n/a
2	Send Data (a), BA	To DSU
14	Send Data (b), BA	To DSU
3	Rcv Data (a), BB	From DSU
16	Rcv Data (b), BB	From DSU
4	RTS (a), CA	To DSU
19	RTS (b), CA	To DSU
5	CTS (a), CB	From DSU
13	CTS (b), CB	From DSU
6	DSR (a), CC	From DSU
22	DSR (b), CC	From DSU
7	Sig Gnd, AB	n/a DSU
8	DCD (a), CF	From DSU
10	DCD (b), CF	From DSU
17	Rcv Clk (a), DD	From DSU
9	Rcv Clk (b), DD	From DSU
24	Ext Clk (a), DA	To DSU
11	Ext Clk (b), DA	To DSU
15	Tx Clk (a), DB	From DSU
12	Tx Clk (b), DB	From DSU
20	DTR (a), CD	To DSU
23	DTR (b), CD	To DSU
21	RDL, RL	To DSU
25	Test Mode, TM	From DSU
18	Local Loop, LL	To DSU

RS-449 (optional interface; use EIA-530 Card)

<u>Pin No.</u>	<u>Function</u>	<u>Direction</u>
1	Frame Ground, AA	n/a
4	Send Data (a), BA	To DSU
22	Send Data (b), BA	To DSU
6	Rcv Data (a), BB	From DSU
24	Rcv Data (b), BB	From DSU
7	RTS (a), CA	To DSU
25	RTS (b), CA	To DSU
9	CTS (a), CB	From DSU
27	CTS (b), CB	From DSU
11	DSR (a), CC	From DSU
29	DSR (b), CC	From DSU
19	Sig Gnd, AB	n/a DSU
13	DCD (a), CF	From DSU
31	DCD (b), CF	From DSU
8	Rcv Clk (a), DD	From DSU
26	Rcv Clk (b), DD	From DSU
17	Ext Clk (a), DA	To DSU
35	Ext Clk (b), DA	To DSU
5	Tx Clk (a), DB	From DSU
23	Tx Clk (b), DB	From DSU
12	DTR (a), CD	To DSU
30	DTR (b), CD	To DSU
14	RDL, RL	To DSU
18	Test Mode, TM	From DSU
10	Local Loop, LL	To DSU

INSTALLATION

DataComm Enclosure Installation

Connect the customer equipment to the DSU by means of the connector labeled **Business Equip 1**, as shown in Figure 2-7. The channel port interface is either a 34-pin female V.35 or 25-pin female subminiature-D connector (for an EIA-530 interface), depending on port configuration.

DataComm FourPak Enclosure Installation

Connect the customer equipment to the DSU by means of the connectors labeled **BUSINESS EQUIP 1** through **BUSINESS EQUIP 3**, as shown in Figure 2-8.

DataComm Shelf Installation

Connect the customer equipment to the DSU by means of the connectors labeled **Business Equip 1** through **Business Equip 15**, as shown in Figure 2-9.

NOTE

When you install a DSU in a DataComm Shelf, you must ground the customer equipment cables, as described under Electrical Connections.

When you install the DataComm 552A-1 V1.1 in any dc powered DataComm shelf, you should select "OPEN" for the ground option (jumper X1). For shelf grounding follow the guidelines in the shelf manual, or observe telco/Bellcore practices, whichever is applicable.

GDC TriPak Shelf Installation

Connect the customer equipment to the DSU by means of the connectors labeled **BUSINESS EQUIP A** and **BUSINESS EQUIP B**, as shown in Figure 2-10.

Universal System Shelf Installation

Connect the customer equipment to the DSU by means of the connectors labeled **BUSINESS EQUIP 1** through **BUSINESS EQUIP 3**, as shown in Figure 2-11.

Network Port Connection

Connect the network (T1 line) to the DSU as described below.

Unless otherwise noted, the network port interface is an RJ48C jack located on the rear panel. Refer to Table 2-7 and Figure 2-13 for the appropriate interface cable.

For other than a DataComm Shelf installation, you must use either GDC cable P/N 022H024-XXX (RJ48C plug-to-plug) or 022H021-XXX (RJ48C plug-to-terminal lugs) to connect the T1 line to the DSU. For a DataComm Shelf installation, you must use either 027H242-X04 (and coupler 209-038-002) or 022H025-XXX. Using any other cable may cause damage to the DSU or the network. Cables 027H242-X04 and 022H024-XXX are labeled **NETWORK** and **CSU** to indicate where each end is used. The pinouts for the network end of these cables are listed below:

Function	Direction	027H242-X04	022H025-XXX
		022H024-XXX	022H021-XXX
		Pin No.	Wire color
Receive Data (Ring)	To DSU	1	ORN/WHT
Receive Data (Tip)	To DSU	2	WHT/ORN
Send Data (Ring)	From DSU	4	BLU/WHT
Send Data (Tip)	From DSU	5	WHT/BLU
Shield (Frame Gnd.)	n/a	7	DRAIN

NOTE: The remaining leads are not used.

CAUTION

If you connect two DSUs back-to-back (a direct cable connection), do not enable automatic Network Line Build-Out for both of them.

NOTE

- a. *For compliance with FCC Part 15, Subpart J, Class A requirements, this installation procedure must be followed.*
- b. *For Canadian installations only, a special cable is required for the network port connection. Use GDC cable P/N 022H020-XXX (RJ48C plug to 15-pin female) to connect the network port to the T1 line.*

DataComm Enclosure Installation

Connect the network to the DSU by means of the jack labeled **Network**, as shown in Figure 2-7.

DataComm FourPak Enclosure Installation

Connect the network to the DSU by means of the jacks labeled **NET 2** through **NET 4**, as shown in Figure 2-8. When you install a DSU in slots three and four (the lower two slots), you must install the rear panel option jumper in the T1 position.

DataComm Shelf Installation

Connect the network to the DSU by means of the jacks labeled **J2** through **J16**, as shown in Figure 2-9.

INSTALLATION

CAUTION

The RJ48C network jack in the DataComm Shelf has a pinout different from all other housings for the DSU. For this reason, you must use either GDC cable P/N 027H242-X04 and coupler 209-038-002 (RJ48C plug-to-jack), or 022H025-XXX (RJ48C plug-to-terminal lugs). Using any other cable may cause damage to the DSU or the network. The pinouts for the network end of these cables are listed above.

GDC TriPak Shelf Installation

Connect the network to the DSU by means of the jacks labeled **J2** and **J3**, as shown in Figure 2-10. You must install the appropriate rear panel option jumper in the T1.5 position.

Universal System Shelf Installation

Connect the network to the DSU by means of the jacks labeled **NET 2** through **NET 4**, as shown in Figure 2-11. When you install a DSU in slots three and four (the rightmost two slots) of a quadrant, you must install the rear panel option jumper in the T1 position.

Supervisory Port Connection

To allow software-control of configuration, diagnostics, and maintenance, connect the Supervisory terminal as described below. It can be connected directly to the DSU, or indirectly using modems or PMC-100 Performance Monitor Cards. Modems allow the Supervisory terminal to be located away from the DSU, while PMC-100s provide enhanced network control and allow one Supervisory terminal to be easily shared among all DSUs in the network. The Supervisory terminal can be any ANSI X3.64-compatible ASCII terminal that supports asynchronous EIA/TIA-232-E communications. The DSU Supervisory port supports:

- data rates from 2,400 to 19,200 bps
- one start bit
- a word length of 7 or 8 data bits
- even, odd, or no parity
- one stop bit

See Figure 2-3 for the switch selections required to match the DSU to the Supervisory terminal's parameters.

NOTE

- a. *Be sure to configure each DSU in the network to match the Supervisory terminal's data rate and character format.*

- b. *The Supervisory port is enabled only when PMC-100 operation is disabled.*

The Supervisory port pin functions for all installations are as follows:

<u>Pin No.</u>	<u>Function</u>	<u>Direction</u>
2	Send Data	From terminal
3	Receive Data	To terminal
7	Signal Ground	n/a

Refer to Supervisory Terminal Operating Procedures in Section 3 for further discussion.

**DIRECT
CONNECTION
APPLICATION**

The following paragraphs describe directly connecting an on-site Supervisory terminal to the DSU's Supervisory port. However, this basic information applies also to connecting the Supervisory terminal via other devices (such as modems and PMC-100s) described later for other applications.

NOTE

When accessing a DSU configured for Monitor privileges via a directly-connected Supervisory terminal, select Modem (press M) when prompted for Supervisory Terminal Access, then access the Modem Session Privileges screen (press P) to select your Supervisory privileges. (Refer to Supervisory Terminal Operating Procedures in Section 3.)

Unless otherwise noted, the Supervisory port interface is a 25-pin male subminiature-D (DB25P) EIA/TIA-232-E connector located on the rear panel. Refer to Table 2-7 and Figure 2-14 for the appropriate interface cable. The DSU requires that the signals be connected to the pins as shown in the appropriate figure.

DataComm Enclosure Installation

Connect the Supervisory terminal to the DSU by means of the connector labeled **Auxiliary 1**, as shown in Figure 2-7.

DataComm FourPak Enclosure Installation

Refer to Figure 2-8 to connect the Supervisory terminal to the DSU by means of the connectors labeled **AUXILIARY 1** through **AUXILIARY 3**.

DataComm Shelf Installation

Connect the Supervisory terminal to the DSU by means of the connectors labeled **Telephone 1** through **Telephone 15**, as shown in Figure 2-9.

INSTALLATION

GDC TriPak Shelf Installation

See Figure 2-10 to connect the Supervisory terminal to the DSU by means of the connectors labeled **AUX-A** and **AUX-B**.

Universal System Shelf Installation

Connect the Supervisory terminal to the DSU by means of the connectors labeled **AUXILIARY 1** through **AUXILIARY 3** (See Figure 2-11).

MODEM APPLICATION

In an application using modems for access to the Supervisory port from a remotely-located Supervisory terminal, such as illustrated in Figure 2-15, one modem is required for the terminal and one for each DSU.

NOTE

When accessing a DSU configured for Monitor privileges via a remotely-located Supervisory terminal connected via modems, select Modem (press M) when prompted for Supervisory Terminal Access, then access the Modem Session Privileges screen (press P) to select your Supervisory privileges. (Refer to Supervisory Terminal Operating Procedures in Section 3.)

At the service center:

- Connect the modem to the Supervisory terminal as shown. Refer to Table 2-7 and Figure 2-14 for the appropriate interface cable. The Supervisory port requires that the signals described above be supported. For the modem, select XOFF/XON flow control (if applicable, to prevent losing data when the modem is operating at a slower speed than the terminal).

At each DSU site:

- Connect the modem to the DSU by means of the Supervisory port connector on the DSU rear panel, as shown in the appropriate figure. Refer to Table 2-7 and Figure 2-16 for the appropriate interface cable. The DSU requires that the signals be connected to the pins as shown. For the modem, enable Auto Answer (for unattended operation), disable terminal commands (to prevent the modem from responding to commands intended for the DSU), and select XOFF/XON flow control (if applicable, to prevent losing data when the modem is operating at a slower speed than the DSU).

PMC-100 APPLICATION

In a PMC-100 application, such as illustrated in Figures 1-3 through 1-6, the Supervisory terminal can be used to access all DSUs in the network. The PMC-100s at the hub site allow direct access to their DSUs, as well as access to the other sites' DSUs via in-band communication. The modem at each of the other sites allows access to its DSU via out-of-band communication.

NOTE

- a. Be sure to select a unique network address number, and enable PMC-100 Operation, for each DSU in the network.
- b. When PMC-100 Operation is enabled for a DSU, the DSU's Supervisory port is disabled. Supervisory terminal communications are handled on the RS-485 bus interconnecting the units.
- c. When accessing a DSU configured for Monitor privileges via a PMC-100, select Inband (press I) when prompted for Supervisory Terminal Access. Your Supervisory privileges are restricted to MONITOR ONLY. (Refer to Supervisory Terminal Operating Procedures in Section 3.)

Refer to the PMC-100 manual for additional PMC-100 installation instructions.

Primary Power Connection

After the above connections have been made, the options selected, and the DSUs installed, refer to the following instructions on connecting primary power to the system. The outlet used to provide ac power, where applicable, should not be under switch control. The DSU should be powered by the same ac source as the customer equipment interfaced with it to prevent large circulating currents caused by differences in ground potential. If it is not possible to determine whether the customer equipment is powered by the same ac source, it should be verified that a potential difference of less than 0.25 V rms exists between the grounding circuits of the respective outlets.

CAUTION

This unit incorporates internal fusible links, FL1 on the CSU-function card, and FL1 and FL2 on the DSU-function card (illustrated in Figure 2-1), which may be opened if the ground potential between the unit and peripheral equipment exceeds 0.25 V rms. Do not apply power to the unit until all connections to the peripheral equipment have been made. If a fusible link is opened, return the unit for repair.

NOTE

The Telco continuously monitors the T1 link and the equipment connected to it. Before connecting the DSU to the network, or disconnecting it, the Telco should be notified.

INSTALLATION

DataComm Enclosure Installation

The DataComm Enclosure is equipped with a captive ac power cord terminated in a molded three-prong plug. Plug the cord into a polarized outlet providing the required ac power.

DataComm FourPak Enclosure Installation

The DataComm FourPak Enclosure is equipped with a captive ac power cord terminated in a molded three-prong plug. Plug the cord into a polarized outlet providing the required ac power.

DataComm Shelf Installation

Refer to the appropriate Instruction Manual for details.

GDC TriPak Shelf Installation

Refer to the Instruction Manual for details.

Universal System Shelf Installation

Refer to the appropriate Instruction Manual for details.

DataComm Shelf Grounding Jumpers

In order to meet FCC radio frequency (RF) suppression requirements when you install a DSU in a DataComm Shelf, you must install grounding jumpers to ground the shielded customer equipment cables connected to the channel port connectors. One grounding jumper, GDC P/N 024H005-X03, is required for each DSU.

The grounding jumper consists of two pieces of wire — a short wire (2" long) and a long wire (3 1/2" long) — connected together at one end and terminated in a lug. The other ends are separate and each is terminated in a lug. Each jumper grounds two customer equipment cables.

NOTE

For compliance with FCC Part 15, Subpart J, Class A requirements, this installation procedure must be followed.

To install a grounding jumper:

1. Securely attach the common end of the jumper to the closest shelf screw, as shown in Figure 2-16. You can attach two jumpers to each shelf screw, grounding four cables.
2. Securely attach the other end of each wire to a customer equipment cable, using the cable mounting screw. When one channel is not used, connect both wires to the same cable.

TABLE 2-1. OPTION APPLICATION NOTES

Option	Selection	Switch (S) or Jumper (X)	Position	Description
CSU-Function Card Options — Switch S3 (Figure 2-3, Sheet 1)				
Network Frame Format	ESF framing	S3-1	OFF *	Selects Extended Superframe Format (ESF) framing for the network side (when S3-3 is ON).
	D4 framing	S3-1	ON	Selects D4 Superframe Format (D4) framing for the network side (when S3-3 is ON).
Auto Framing	Disabled	S3-3	ON *	Disables Auto Framing for the network side. Use S3-1 to manually select framing.
	Enabled	S3-3	OFF	Enables Auto Framing: the DSU adapts to the received framing for the network side. CAUTION: <i>Do not enable Auto Framing for both DSUs on a link.</i>
Line Code	AMI	S3-5	OFF *	Selects Alternate Mark Inversion (AMI) line code for the network side.
	B8ZS	S3-5	ON	Selects Bipolar with 8 Zero Substitution (B8ZS) line code for the network side.
In-Band DS1 Loopback Code Test Type	DS1 Line Loop	S3-6	OFF *	The DSU starts or stops a DS1 Line Loop test when the appropriate in-band loopback code is detected (when S4-8 is OFF).
	DS1 Test Loop	S3-6	ON	The DSU starts or stops a DS1 Test Loop test when the appropriate in-band loopback code is detected (when S4-8 is OFF).
In-Band DS1 Loopback Code Framing	Framed	S3-7	OFF *	The DSU sends framed in-band loopback codes.
	Unframed	S3-7	ON	The DSU sends unframed in-band loopback codes.
Ones Density	15 zeros	S3-8	OFF *	Allows a maximum of 15 consecutive zeros to be sent toward the network.
	39 zeros	S3-8	ON	Allows a maximum of 39 consecutive zeros to be sent toward the network.
* Factory default position.				

INSTALLATION

TABLE 2-1. OPTION APPLICATION NOTES (Cont.)

Option	Selection	Switch (S) or Jumper (X)	Position	Description															
CSU-Function Card Options — Switch S4 (Figure 2-3, Sheet 2)																			
Supervisory Port Baud Rate	4 rates: 2.4 to 19.2 kbps	S4-1 S4-2	Various	Selects the baud rate for the Supervisory port, as follows: <table border="1" style="margin-left: 20px;"> <tr> <td><u>Baud Rate</u></td> <td><u>S4-1</u></td> <td><u>S4-2</u></td> </tr> <tr> <td>2400 bps</td> <td>ON</td> <td>ON</td> </tr> <tr> <td>4800 bps</td> <td>OFF</td> <td>ON</td> </tr> <tr> <td>9600 bps</td> <td>OFF *</td> <td>OFF *</td> </tr> <tr> <td>19.2 kbps</td> <td>ON</td> <td>OFF</td> </tr> </table>	<u>Baud Rate</u>	<u>S4-1</u>	<u>S4-2</u>	2400 bps	ON	ON	4800 bps	OFF	ON	9600 bps	OFF *	OFF *	19.2 kbps	ON	OFF
<u>Baud Rate</u>	<u>S4-1</u>	<u>S4-2</u>																	
2400 bps	ON	ON																	
4800 bps	OFF	ON																	
9600 bps	OFF *	OFF *																	
19.2 kbps	ON	OFF																	
PMC-100 Operation	Disabled	S4-3	OFF *	Disables use of PMC-100s (disables the internal RS-485 bus and enables the Supervisory port).															
	Enabled	S4-3	ON	Enables use of PMC-100s (enables the internal RS-485 bus and disables the Supervisory port). Use S5-1 to S5-8 to select a network address.															
Supervisory Port Character Format	Various	S4-4 S4-5	Various	Selects the character format for the Supervisory port, as follows (word length / parity / stop bits): <table border="1" style="margin-left: 20px;"> <tr> <td><u>Format</u></td> <td><u>S4-4</u></td> <td><u>S4-5</u></td> </tr> <tr> <td>7 / E / 1</td> <td>ON</td> <td>ON</td> </tr> <tr> <td>7 / N / 1</td> <td>OFF</td> <td>ON</td> </tr> <tr> <td>7 / O / 1</td> <td>ON</td> <td>OFF</td> </tr> <tr> <td>8 / N / 1</td> <td>OFF *</td> <td>OFF *</td> </tr> </table>	<u>Format</u>	<u>S4-4</u>	<u>S4-5</u>	7 / E / 1	ON	ON	7 / N / 1	OFF	ON	7 / O / 1	ON	OFF	8 / N / 1	OFF *	OFF *
<u>Format</u>	<u>S4-4</u>	<u>S4-5</u>																	
7 / E / 1	ON	ON																	
7 / N / 1	OFF	ON																	
7 / O / 1	ON	OFF																	
8 / N / 1	OFF *	OFF *																	
Soft Configuration Privileges	Full control (master DSU)	S4-6	OFF *	Allows unrestricted Supervisory terminal configuration and diagnostics privileges (when S6-7 is ON).															
	Monitor (slave DSU)	S4-6	ON	Restricts Supervisory terminal privileges (when S6-7 is ON).															
Front Panel Switches	Enabled	S4-7	OFF *	Allows use of the front panel test switches.															
	Disabled	S4-7	ON	Disables use of the front panel test switches.															
In-Band DS1 Loopback Code Detection	Enabled	S4-8	OFF *	Enables detection of in-band loopback codes. Select test type with S3-6.															
	Disabled	S4-8	ON	Disables detection of in-band loopback codes.															
CSU-Function Card Options — Switch S5 (Figure 2-3, Sheet 3)																			
DSU Address Number	256 addresses, from 000 to 255	S5-1 through S5-8	Various (see Fig. 2-3 and Table 2-2)	Selects address number for DSU when using PMC-100s (S4-3 must be ON). Each DSU must have a unique address number. Factory default is address number 000 (all switches OFF).															
* Factory default position.																			

TABLE 2-1. OPTION APPLICATION NOTES (Cont.)

Option	Selection	Switch (S) or Jumper (X)	Position	Description												
CSU-Function Card Options — Switch S6 (Figure 2-3, Sheet 4)																
Network Line Build-Out	Manual	S6-4	OFF *	Selects manual LBO (attenuation of signal transmitted to the network). Use S6-5 and S6-6 to manually select amount of attenuation.												
	Automatic	S6-4	ON	Selects automatic LBO. CAUTION: <i>Do not enable automatic LBO for both DSUs when they are connected back-to-back. Do not enable automatic LBO when the DSU is connected to a DS1 Interface Connector (or Smart Jack): use manual LBO with the proper attenuation.</i>												
Network Line Build-Out Amount	0 dB, 7.5 dB, and 15 dB	S6-5 S6-6	Various	Matches transmitter to network gain characteristics (when S6-4 is OFF), as follows: <table style="margin-left: auto; margin-right: auto; border-collapse: collapse;"> <tr> <td style="padding: 2px;"><u>Attenuation</u></td> <td style="padding: 2px;"><u>S6-5</u></td> <td style="padding: 2px;"><u>S6-6</u></td> </tr> <tr> <td style="padding: 2px;">0 dB</td> <td style="padding: 2px;">OFF *</td> <td style="padding: 2px;">OFF *</td> </tr> <tr> <td style="padding: 2px;">7.5 dB</td> <td style="padding: 2px;">OFF</td> <td style="padding: 2px;">ON</td> </tr> <tr> <td style="padding: 2px;">15 dB</td> <td style="padding: 2px;">ON</td> <td style="padding: 2px;">n/a</td> </tr> </table>	<u>Attenuation</u>	<u>S6-5</u>	<u>S6-6</u>	0 dB	OFF *	OFF *	7.5 dB	OFF	ON	15 dB	ON	n/a
<u>Attenuation</u>	<u>S6-5</u>	<u>S6-6</u>														
0 dB	OFF *	OFF *														
7.5 dB	OFF	ON														
15 dB	ON	n/a														
Configuration Mode	Soft	S6-7	ON *	Supervisory terminal selections override option switch selections.												
	Hard	S6-7	OFF	Option switch selections override Supervisory terminal selections.												
Network Compatibility	ANSI mode	S6-8	OFF *	Selects compliance with ANSI network performance messages (per Bellcore TR-TSY-000194), available only with ESF framing on network side.												
	PUB 54016 mode	S6-8	ON	Selects compliance with TABS network maintenance messages (per PUB 54016), available only with ESF framing on network side.												
CSU-Function Card Options — Jumpers X1 and X5 (Figure 2-1, Sheet 1)																
Ground	Open	X1	OPEN *	Opens frame (chassis) and signal (reference) grounds.												
	Common	X1	0	Commons frame and signal grounds (connected through fusible link FL1).												
	Isolated	X1	100	Isolates frame and signal grounds by 100 .												
Loop Span	Enabled	X5	Pins 5 & 6 *	The DSU loops span power.												
Power	Disabled	X5	Pins 6 & 7	The DSU does not loop span power.												
<p>* Factory default position.</p> <p>When you install the DataComm 552A-1 V1.1 in any dc powered DataComm shelf, you should select "OPEN" for the ground option (jumper X1). For shelf grounding follow the guidelines in the shelf manual, or observe telco/Bellcore practices, whichever is applicable.</p>																

INSTALLATION

TABLE 2-1. OPTION APPLICATION NOTES (Cont.)

Option	Selection	Switch (S) or Jumper (X)	Position	Description
DSU-Function Card Options — Switch S14A (Figure 2-3, Sheet 5)				
Internal Timing	Disabled	S14A-1	OFF *	Disables Internal Timing. NOTE: To enable Slave Timing (factory default), turn OFF switches S14A-1, S14A-2, and S14A-5. With Slave Timing, the network or a device at the remote end provides the timing source.
	Enabled	S14A-1	ON	Enables Internal Timing (the DSU provides the timing source).
Channel Timing	Disabled	S14A-2	OFF *	Disables Channel Timing.
	Enabled	S14A-2	ON	Enables Channel Timing (the customer channel equipment provides the timing source).
Channel Split Timing	Disabled	S14A-5	OFF *	Disables Channel Split Timing.
	Channel Split Timing	S14A-5	ON	Enables Channel Split Timing (the customer channel equipment provides its own transmit timing source, while the network provides the timing source for everything else).
Invert Channel Timing	Disabled	S14A-7	OFF *	Disables Invert Channel Timing.
	Enabled	S14A-7	ON	Enables Invert Channel Timing (the 552A-1 inverts it's internal channel transmit clock signal).
DSU-Function Card Options — Switches S15, S16, and S10 (Figure 2-3, Sheets 6 and 7)				
Channel Data Rate	From 0 to 1536 kbps	S15-1 through S15-5	Various (see Fig. 2-3 and Table 2-4)	Factory default is 56 kbps (switch S15-1 ON, all others OFF).
DS0 Type	Nx56 kbps	S15-6	ON *	The LSB of each DS0 is forced to a mark. Only 7 bits of each DS0 are used for payload.
	Nx64 kbps	S15-6	OFF	All 8 bits of each DS0 are used for payload.
Starting DS0 Number	From 1 to 24	S15-7 through S16-3	Various (see Fig. 2-3 and Table 2-3)	Factory default is DS0 number 1 (all switches OFF).
Alternate DS0	Consecutive	S10-7	OFF *	Selects consecutive DS0s for payload.
	Alternate	S10-7	ON	Selects alternate DS0s for payload. Unused DS0s are forced to marks.
Channel RDL Response	Enabled	S10-8	OFF *	Enables response to in-band channel loopback codes.
	Disabled	S10-8	ON	Disables response to in-band channel loopback codes.
<p>* Factory default position.</p> <p>NOTE:</p> <p>a. All timing options that include split timing require each timing source to be traceable to a Stratum 1 clock.</p> <p>b. Discussion of the timing options is too extensive to include in this table. Refer to Appendix B for timing option details and applications.</p>				

TABLE 2-1. OPTION APPLICATION NOTES (Cont.)

Option	Selection	Switch (S) or Jumper (X)	Position	Description
DSU-Function Card Options — Switch S12 (Figure 2-3, Sheet 8)				
Remote Digital Loop Pattern	PN-127	S12-1	ON *	Selects scrambled loop-up/-down in-band codes for RDL (the recommended setting).
	7-bit	S12-1	OFF	Selects 7-bit fixed loop-up/-down in-band codes for RDL.
Remote Digital Loop Enable	Disabled	S12-2	OFF *	Blocks RDL interface signal into DSU. **
	Enabled	S12-2	ON	Passes RDL interface signal into DSU. **
Test Mode Status	Disabled	S12-3	OFF *	Blocks Test Mode interface signal out of DSU. **
	Enabled	S12-3	ON	Passes Test Mode interface signal out of DSU. **
Digital Loop Enable	Disabled	S12-4	OFF *	Blocks DL interface signal into DSU. **
	Enabled	S12-4	ON	Passes DL interface signal into DSU. **
Local Loop Enable	Disabled	S12-5	OFF *	Blocks Local Loop interface signal into DSU. **
	Enabled	S12-5	ON	Passes Local Loop interface signal into DSU. **
DSR Operation	Forced ON	S12-6	ON *	DSR forced ON. **
	Normal	S12-6	OFF	DSR controlled by DCE. **
CMI Signalling	Disabled	S12-7	OFF *	Disables CMI (Control Mode Idle) signalling.
	Enabled	S12-7	ON	Enables CMI signalling for polling applications.
CTS Operation	10 ms delay	S12-8	OFF *	CTS asserted 10 ms after RTS into DSU. **
	Forced ON	S12-8	ON	CTS forced ON. **
* Factory default position.				
** This option affects the operation of the stated EIA input/output lead on the channel interface (connector).				

INSTALLATION

TABLE 2-2. DSU ADDRESS SELECTION

DSU Address = AD7/AD6/AD5/AD4/AD3/AD2/AD1/AD0 (Option Switches S5-8 to S5-1)				
0 = Switch OFF; 1 = Switch ON (see example below)				
0=0000000	51=00110011	102=01100110	153=10011001	204=11001100
1=0000001	52=00110100	103=01100111	154=10011010	205=11001101
2=0000010	53=00110101	104=01101000	155=10011011	206=11001110
3=0000011	54=00110110	105=01101001	156=10011100	207=11001111
4=0000100	55=00110111	106=01101010	157=10011101	208=11010000
5=0000101	56=00111000	107=01101011	158=10011110	209=11010001
6=0000110	57=00111001	108=01101010	159=10011111	210=11010010
7=0000111	58=00111010	109=01101101	160=10100000	211=11010011
8=00001000	59=00111011	110=01110110	161=10100001	212=11010100
9=00001001	60=00111100	111=01101111	162=10100010	213=11010101
10=00001010	61=00111101	112=01110000	163=10100011	214=11010110
11=00001011	62=00111110	113=01110001	164=10100100	215=11010111
12=00001100	63=00111111	114=01110010	165=10100101	216=110101000
13=00001101	64=01000000	115=01110011	166=10100110	217=11011001
14=00001110	65=01000001	116=01110100	167=10100111	218=11011010
15=00001111	66=01000010	117=01110101	168=10101000	219=11011011
16=00010000	67=01000011	118=01110110	169=10101001	220=11011100
17=00010001	68=01000100	119=01110111	170=10101010	221=11011101
18=00010010	69=01000101	120=01111000	171=10101011	222=11011110
19=00010011	70=01000110	121=01111001	172=10101100	223=11011111
20=00010100	71=01000111	122=01111010	173=10101101	224=11100000
21=00010101	72=01001000	123=01111011	174=10101110	225=11100001
22=00010110	73=01001001	124=01111100	175=10101111	226=11100010
23=00010111	74=01001010	125=01111101	176=10110000	227=11100011
24=00011000	75=01001011	126=01111110	177=10110001	228=11100100
25=00011001	76=01001100	127=01111111	178=10110010	229=11100101
26=00011010	77=01001101	128=10000000	179=10110011	230=11100110
27=00011011	78=01001110	129=10000001	180=10110100	231=11100111
28=00011100	79=01001111	130=10000010	181=10110101	232=11101000
29=00011101	80=01010000	131=10000011	182=10110110	233=11101001
30=00011110	81=01010001	132=10000100	183=10110111	234=11101010
31=00011111	82=01010010	133=10000101	184=10111000	235=11101011
32=00100000	83=01010011	134=10000110	185=10111001	236=11101100
33=00100001	84=01010100	135=10000111	186=10111010	237=11101101
34=00100010	85=01010101	136=10001000	187=10111011	238=11101110
35=00100011	86=01010110	137=10001001	188=10111100	239=11101111
36=00100100	87=01010111	138=10001010	189=10111101	240=11110000
37=00100101	88=01011000	139=10001011	190=10111110	241=11110001
38=00100110	89=01011001	140=10001100	191=10111111	242=11110010
39=00100111	90=01011010	141=10001101	192=11000000	243=11110011
40=00101000	91=01011011	142=10001110	193=11000001	244=11110100
41=00101001	92=01011100	143=10001111	194=11000010	245=11110101
42=00101010	93=01011101	144=10010000	195=11000011	246=11110110
43=00101011	94=01011110	145=10010001	196=11000100	247=11110111
44=00101100	95=01011111	146=10010010	197=11000101	248=11111000
45=00101101	96=01100000	147=10010011	198=11000110	249=11111001
46=00101110	97=01100001	148=10010100	199=11000111	250=11111010
47=00101111	98=01100010	149=10010101	200=11001000	251=11111011
48=00110000	99=01100011	150=10010110	201=11001001	252=11111100
49=00110001	100=01100100	151=10010111	202=11001010	253=11111101
50=00110010	101=01100101	152=10011000	203=11001011	254=11111110
				255=11111111

Example: To select address 2, turn ON switch S5-2 (labeled AD1), and turn OFF all other address switches.

TABLE 2-3. CHANNEL STARTING DS0 NUMBER SELECTION

Start DS0	Channel Switch Settings				
	S16-3	S16-2	S16-1	S15-8	S15-7
1	OFF *	OFF *	OFF *	OFF *	OFF *
2	OFF	OFF	OFF	OFF	ON
3	OFF	OFF	OFF	ON	OFF
4	OFF	OFF	OFF	ON	ON
5	OFF	OFF	ON	OFF	OFF
6	OFF	OFF	ON	OFF	ON
7	OFF	OFF	ON	ON	OFF
8	OFF	OFF	ON	ON	ON
9	OFF	ON	OFF	OFF	OFF
10	OFF	ON	OFF	OFF	ON
11	OFF	ON	OFF	ON	OFF
12	OFF	ON	OFF	ON	ON
13	OFF	ON	ON	OFF	OFF
14	OFF	ON	ON	OFF	ON
15	OFF	ON	ON	ON	OFF
16	OFF	ON	ON	ON	ON
17	ON	OFF	OFF	OFF	OFF
18	ON	OFF	OFF	OFF	ON
19	ON	OFF	OFF	ON	OFF
20	ON	OFF	OFF	ON	ON
21	ON	OFF	ON	OFF	OFF
22	ON	OFF	ON	OFF	ON
23	ON	OFF	ON	ON	OFF
24	ON	OFF	ON	ON	ON
None **	ON	ON	n/a	n/a	n/a
* Factory default position.					
** This selection sets all bits to one.					

TABLE 2-4. CHANNEL DATA RATE SELECTION

Rate ** Nx56/Nx64	DS0s	Channel Switch Settings				
		S15-5	S15-4	S15-3	S15-2	S15-1
0/0	0	OFF	OFF	OFF	OFF	OFF
56/64	1	OFF *	OFF *	OFF *	OFF *	ON *
112/128	2	OFF	OFF	OFF	ON	OFF
168/192	3	OFF	OFF	OFF	ON	ON
224/256	4	OFF	OFF	ON	OFF	OFF
280/320	5	OFF	OFF	ON	OFF	ON
336/384	6	OFF	OFF	ON	ON	OFF
392/448	7	OFF	OFF	ON	ON	ON
448/512	8	OFF	ON	OFF	OFF	OFF
504/576	9	OFF	ON	OFF	OFF	ON
560/640	10	OFF	ON	OFF	ON	OFF
616/704	11	OFF	ON	OFF	ON	ON
672/768	12	OFF	ON	ON	OFF	OFF
728/832	13	OFF	ON	ON	OFF	ON
784/896	14	OFF	ON	ON	ON	OFF
840/960	15	OFF	ON	ON	ON	ON
896/1024	16	ON	OFF	OFF	OFF	OFF
952/1088	17	ON	OFF	OFF	OFF	ON
1008/1152	18	ON	OFF	OFF	ON	OFF
1064/1216	19	ON	OFF	OFF	ON	ON
1120/1280	20	ON	OFF	ON	OFF	OFF
1176/1344	21	ON	OFF	ON	OFF	ON
1232/1408	22	ON	OFF	ON	ON	OFF
1288/1472	23	ON	OFF	ON	ON	ON
1344/1536	24	ON	ON	OFF	OFF	OFF

* Factory default position.
 ** Turn option switch S15-6 ON for Nx56 kbps DS0s or OFF for Nx64 kbps DS0s.

TABLE 2-5. CHANNEL FLOW CONTROL LEADS

Status of Local DSU	State of DSR		State of CTS		State of
	Normal	Forced ON	10 ms delay	Forced ON	DCD
Initiated Channel Digital Loop	OFF	ON	OFF	OFF	ON
Initiated Channel Self-Test	OFF	ON	OFF	OFF	ON
Responded to Channel Remote Digital Loop	OFF	ON	OFF	OFF	ON
Initiated Channel Remote Digital Loop *	ON	ON	ON	ON	ON
Initiated DS1 Line Loop	OFF	ON	OFF	OFF	ON
Initiated DS1 Self-Test	OFF	ON	OFF	OFF	ON
Initiated DS1 Test Loop	OFF	ON	OFF	OFF	ON
Responded to DS1 Remote Test	OFF	ON	OFF	OFF	ON
Initiated DS1 Local Test *	ON	ON	ON	ON	ON
Initiated DS1 Remote Test *	ON	ON	ON	ON	ON
Network AIS	OFF	ON	ON	ON	OFF
Network LOS	OFF	ON	ON	ON	OFF
Network OOF	OFF	ON	ON	ON	OFF
Network YEL	ON	ON	ON	ON	ON
Configuration Error	OFF	ON	OFF	OFF	OFF
DTR turned OFF	ON	ON	ON	ON	ON
RTS turned OFF	ON	ON	OFF	ON	ON

NOTE:

- When the channel's DSR or CTS lead is negated, its Send Data (data transmitted toward the network) is clamped to the Marking condition.
- When the channel's DCD lead is negated, its Receive Data (data received from the network) is clamped to the Marking condition.

* Includes using this diagnostic with Self-Test.

INSTALLATION

TABLE 2-6. CONNECTOR FUNCTION ASSIGNMENTS

Port	DataComm Enclosure		
	Installed in Slots 1 and 2		
Channel	Business Equip 1		
Network	Network		
Supervisory	Auxiliary 1		
Port	DataComm FourPak Enclosure		
	Installed in Slots 1 and 2	Installed in Slots 2 and 3	Installed in Slots 3 and 4
Channel	BUSINESS EQUIP 1	BUSINESS EQUIP 2	BUSINESS EQUIP 3
Network	NET 2	NET 3	NET 4
Supervisory	AUXILIARY 1	AUXILIARY 2	AUXILIARY 3
Port	DataComm Shelf		
	Installed in Slots 1 and 2	Installed in Slots 2 and 3	Installed in Slots 15 and 16
Channel	Business Equip 1	Business Equip 2	Business Equip 15
Network	J2	J3	J16
Supervisory	Telephone 1	Telephone 2	Telephone 15
Port	GDC TriPak Shelf		
	Installed in Slots 1 and 2	Installed in Slots 2 and 3	
Channel	BUSINESS EQUIP A	BUSINESS EQUIP B	
Network	J2	J3	
Supervisory	AUX-A	AUX-B	
Port	Universal System Shelf quadrant		
	Installed in Slots 1 and 2	Installed in Slots 2 and 3	Installed in Slots 3 and 4
Channel	BUSINESS EQUIP 1	BUSINESS EQUIP 2	BUSINESS EQUIP 3
Network	NET 2	NET 3	NET 4
Supervisory	AUXILIARY 1	AUXILIARY 2	AUXILIARY 3
NOTE:			
<p>a. The DSU has 3 ports: channel, network, and Supervisory. Use this table to determine how each port is labeled on the housing for the slots in which it is installed. For example, if the DSU is installed in slots 2 and 3 in a DataComm FourPak Enclosure, use the following connectors: for the channel, use the connector labeled BUSINESS EQUIP 2; for the network port, use NET 3; and for the Supervisory port, use AUXILIARY 2.</p> <p>b. In the DataComm Enclosure, DataComm FourPak Enclosure and GDC TriPak Shelf, slot 1 is the upper slot. In the DataComm Shelf and in a Universal System Shelf quadrant, slot 1 is the left slot (looking from the front).</p>			

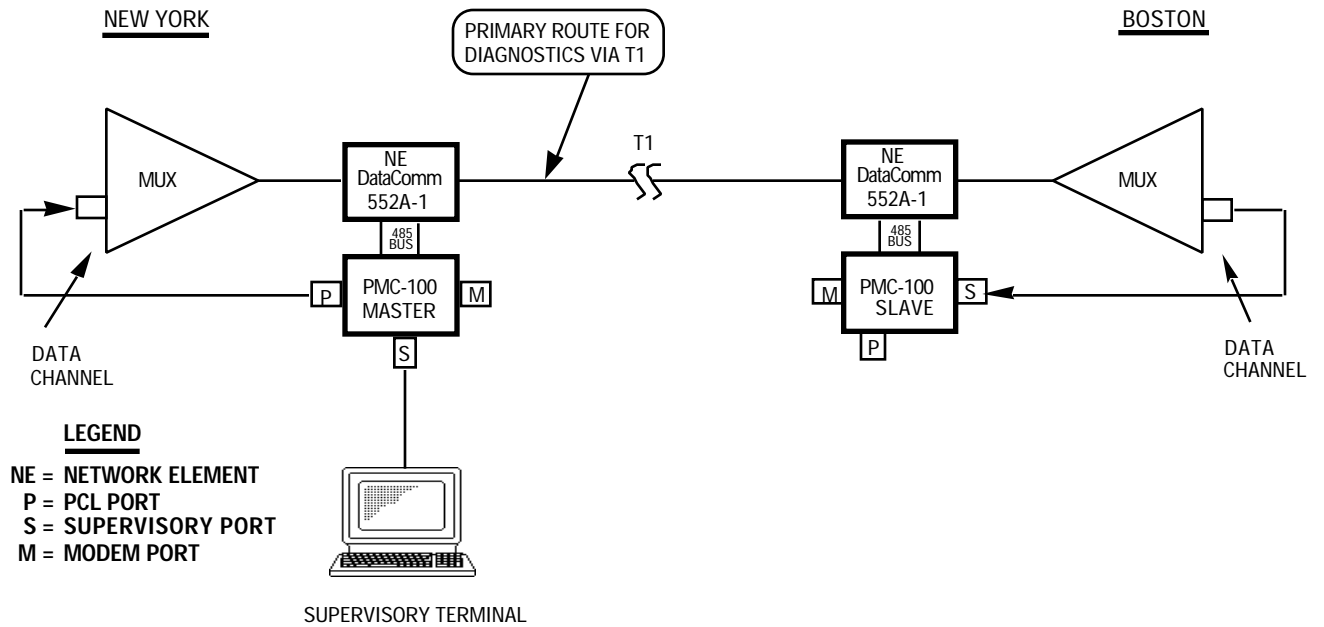

FIGURE 2-5. IN-BAND COMMUNICATION PATH

INSTALLATION

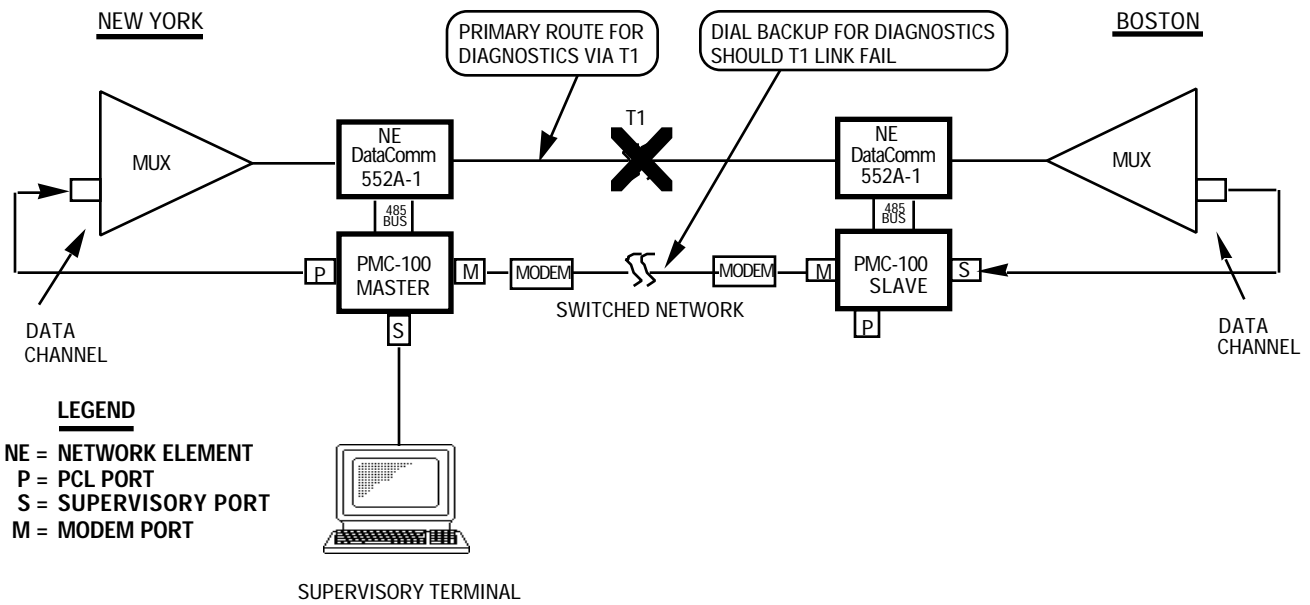
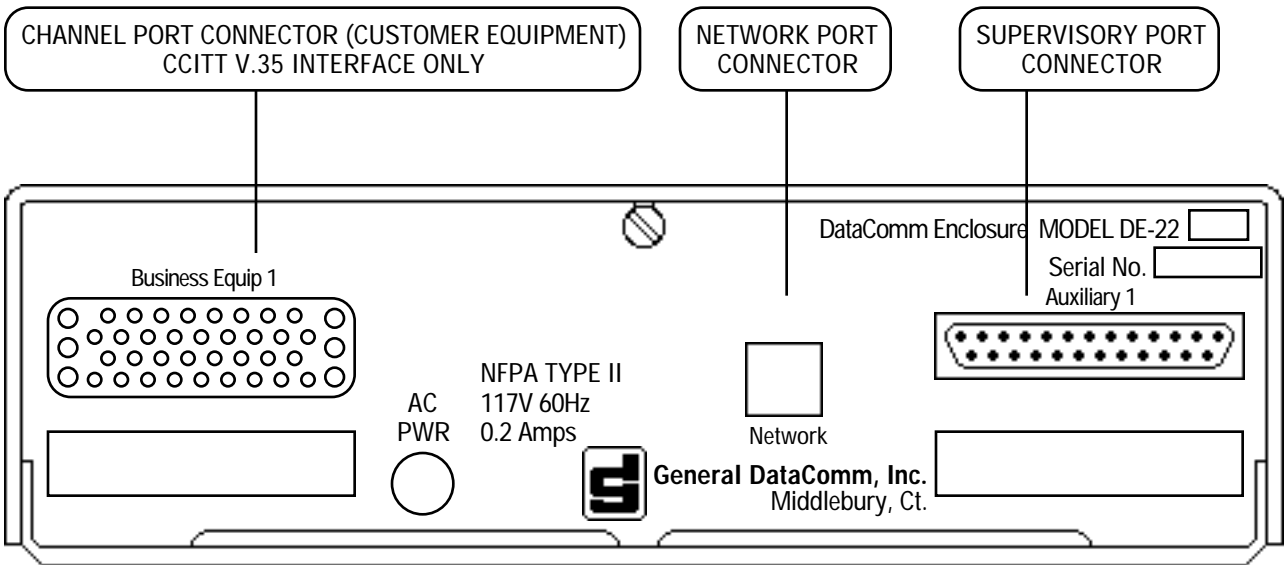
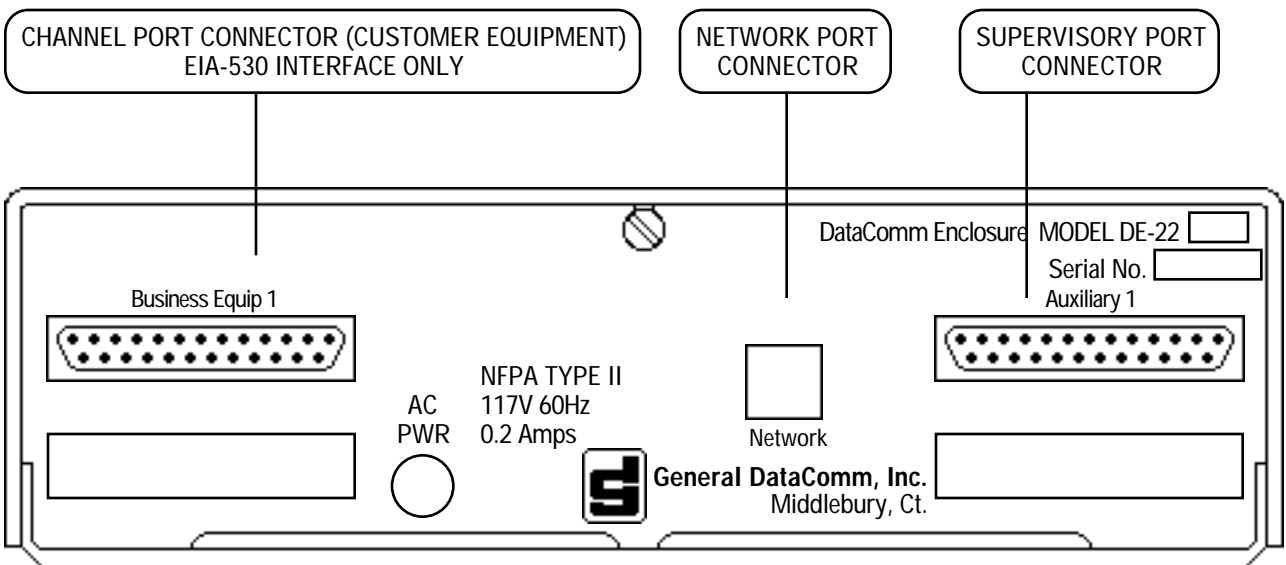

FIGURE 2-6. OUT-OF-BAND COMMUNICATION PATH



A. MODEL DE-22, WITH A CCITT V.35 CHANNEL INTERFACE



B. MODEL DE-22, WITH AN EIA-530 CHANNEL INTERFACE

FIGURE 2-7. DataComm ENCLOSURE INSTALLATION

INSTALLATION

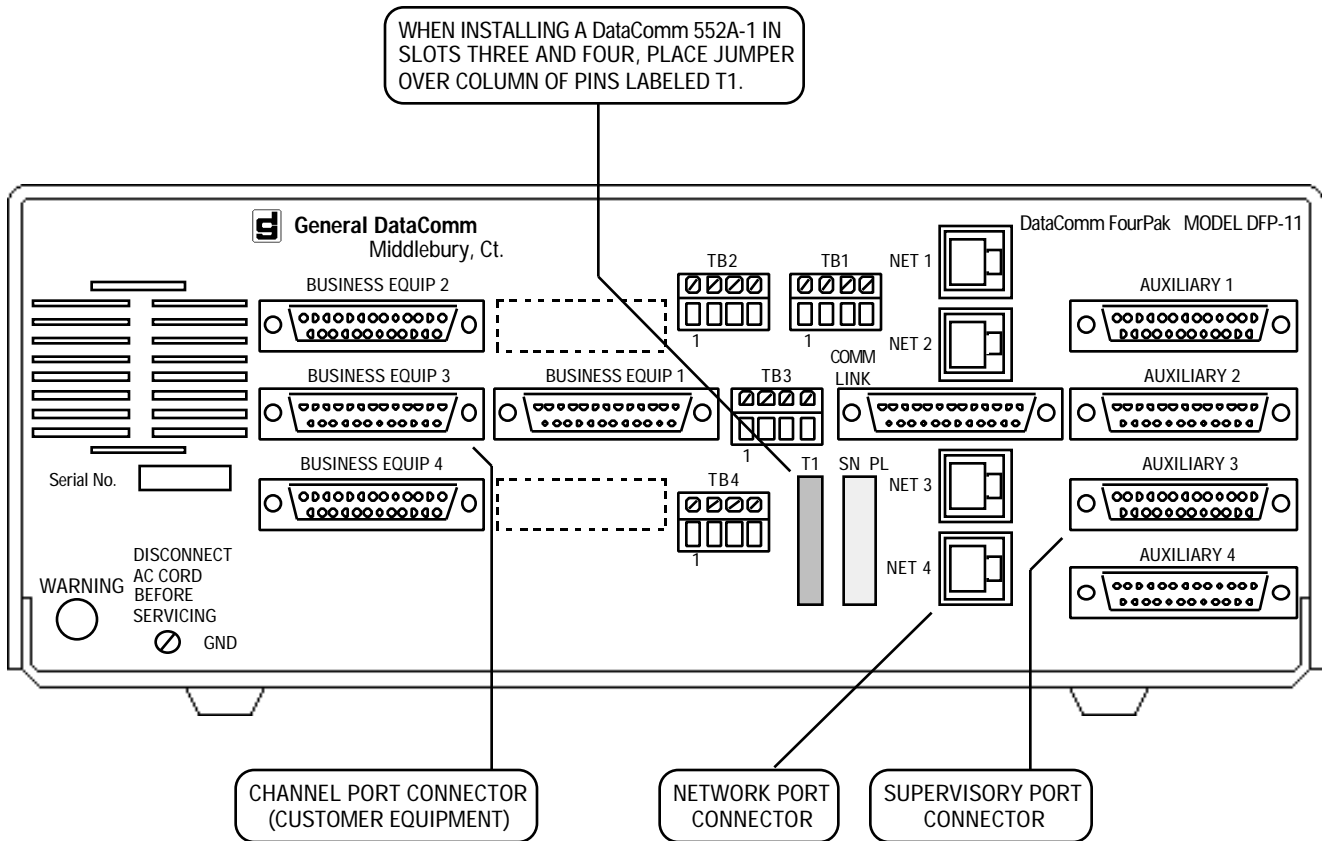

NOTE: CONNECTOR FUNCTIONS INDICATED ARE FOR A DataComm 552A-1 INSTALLED IN SLOTS THREE AND FOUR.

FIGURE 2-8. DataComm FOURPAK ENCLOSURE INSTALLATION

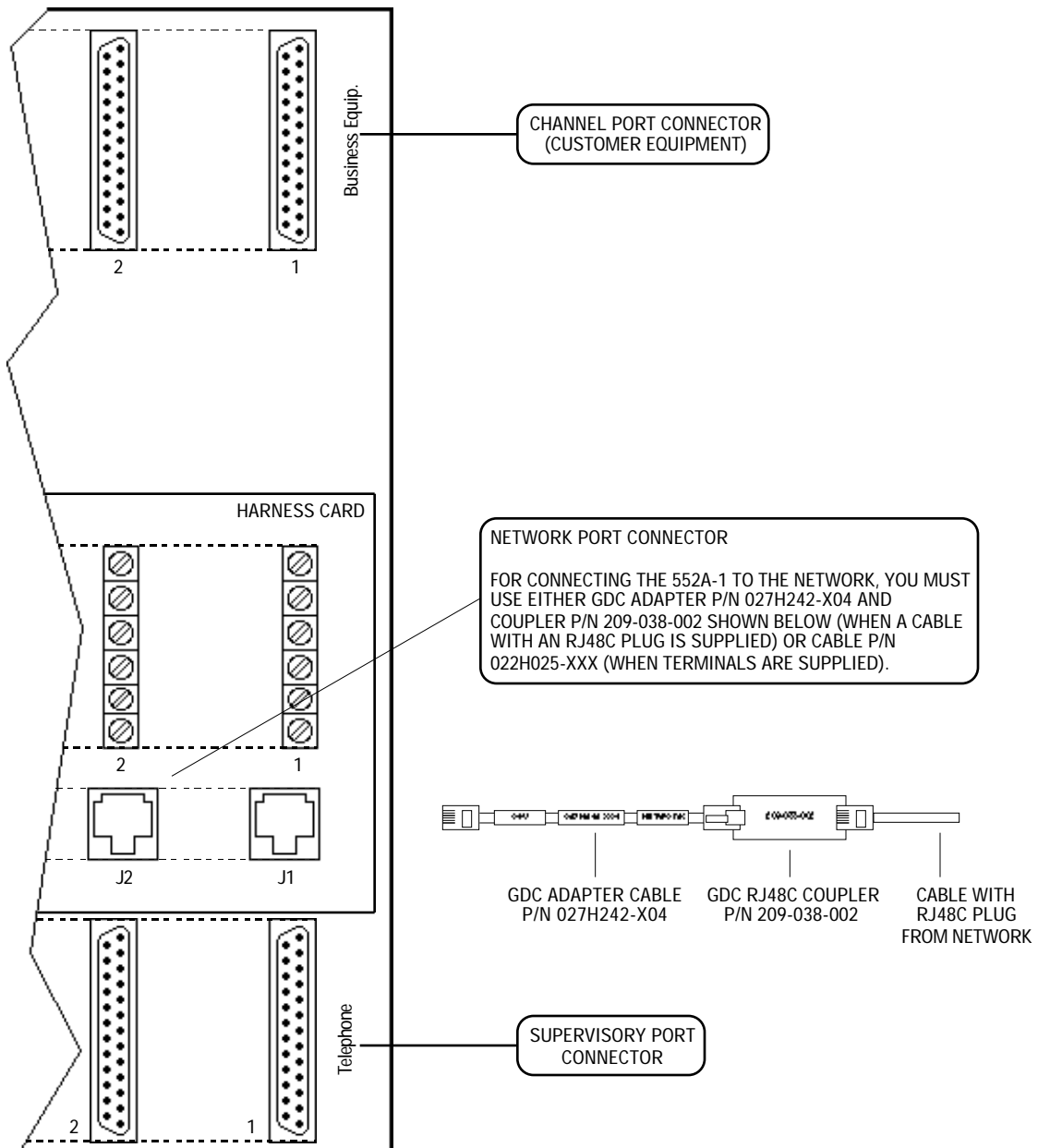

NOTE: CONNECTOR FUNCTIONS INDICATED ARE FOR A DataComm 552A-1 INSTALLED IN SLOTS ONE AND TWO.

FIGURE 2-9. DataComm SHELF INSTALLATION

INSTALLATION

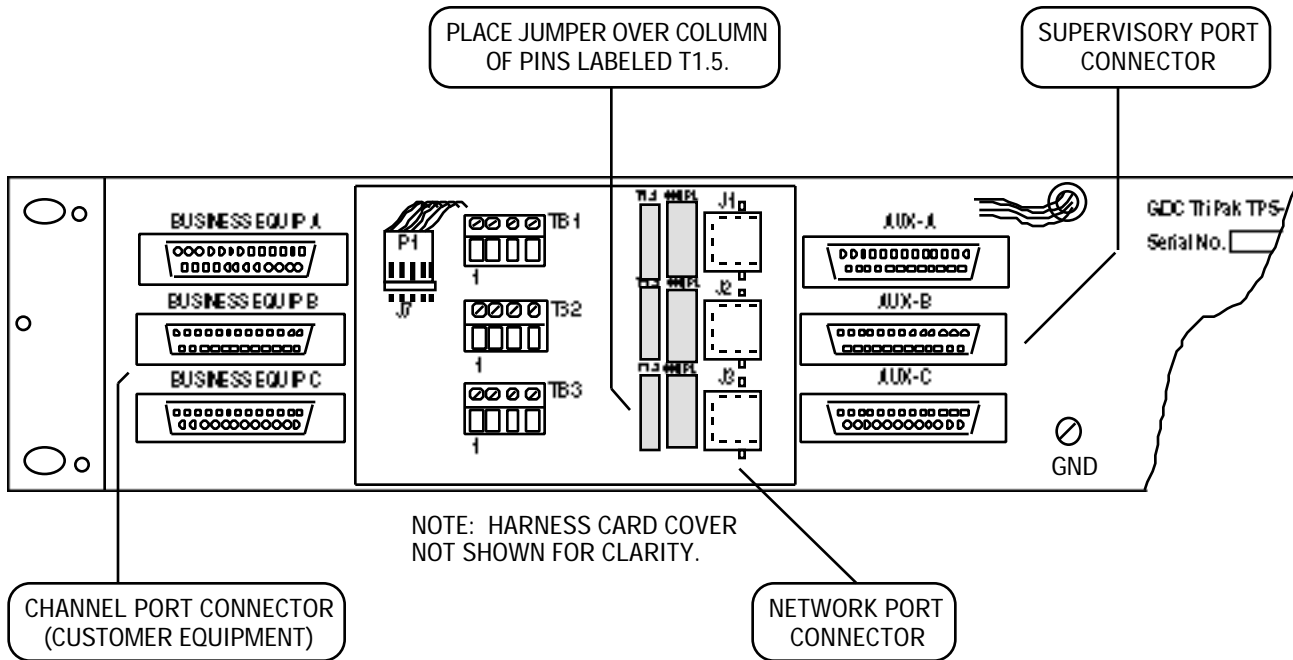

NOTE: CONNECTOR FUNCTIONS INDICATED ARE FOR A DataComm 552A-1 INSTALLED IN SLOTS TWO AND THREE.

FIGURE 2-10. GDC TRIPAK SHELF INSTALLATION

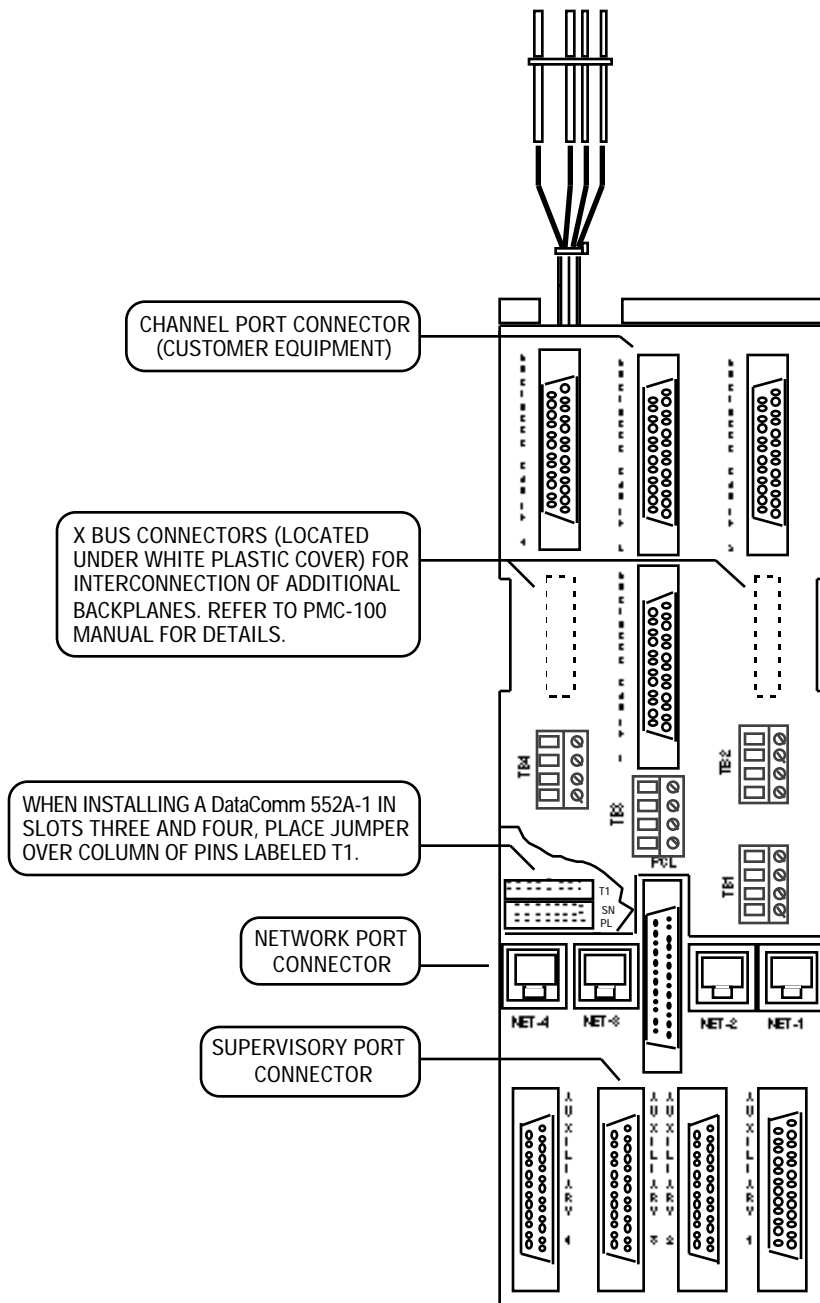

NOTE: CONNECTOR FUNCTIONS INDICATED ARE FOR A DataComm 552A-1 INSTALLED IN SLOTS THREE AND FOUR.

FIGURE 2-11. UNIVERSAL SYSTEM SHELF INSTALLATION

INSTALLATION

TABLE 2-7. CABLE APPLICATIONS

Application	Interface Type	Connectors	GDC P/N
Channel Port			
All housings except DataComm Enclosure Model DE-22 also require adapter cable P/N 027H560-001 (34-pin female to 25-pin male).	CCITT V.35	34-pin male-to-male	027H516-XXX
All housings	EIA-530 (with EIA-530 Card)	25-pin male-to-male OR 25-pin female-to-male	028H502-XXX OR 028H511-XXX
	RS-449 (with EIA-530 Card)	37-pin male to 25-pin male OR 37-pin female to 25-pin male adapter	023H603-XXX OR 027H501-001
Connection to a multiplexer aggregate	RS-422 (with EIA-530 Card)	25-pin male-to-male	027H531-XXX
Network Port			
All housings	FT1	RJ48C plug-to-plug OR RJ48C plug-to-lugs	022H024-XXX OR 022H021-XXX
DataComm Shelf only	FT1	Adapter cable and coupler (for RJ48C plug) OR RJ48C plug-to-lugs	027H242-X04 209-038-002 OR 022H025-XXX
Supervisory Port			
Connection to a terminal	EIA/TIA-232-E	25-pin male-to-female OR 25-pin female-to-female	028H511-XXX OR 028H507-XXX
Connection to a modem	EIA/TIA-232-E	25-pin female-to-male	028H311-XXX
Connection to a multiplexer channel	EIA/TIA-232-E	25-pin male-to-female OR 25-pin female-to-female	028H511-XXX OR 028H507-XXX
XXX — length, varies per customer order (refer to Cables in Table 1-1).			
NOTE: When two cables are listed: use the first cable when the device has a female connector; use the second cable when the device has a male connector.			

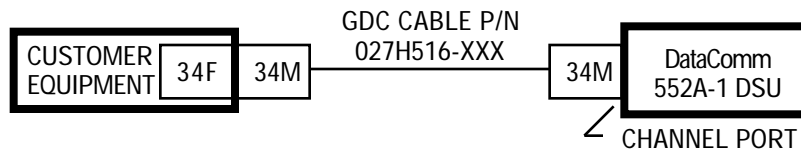

A. DataComm ENCLOSURE MODEL DE-22 WITH A CCITT V.35 INTERFACE

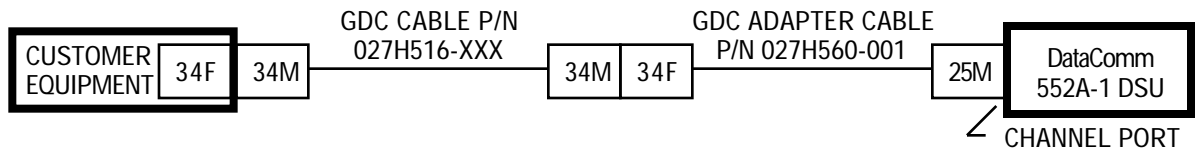

B. ALL OTHER HOUSINGS WITH A CCITT V.35 INTERFACE

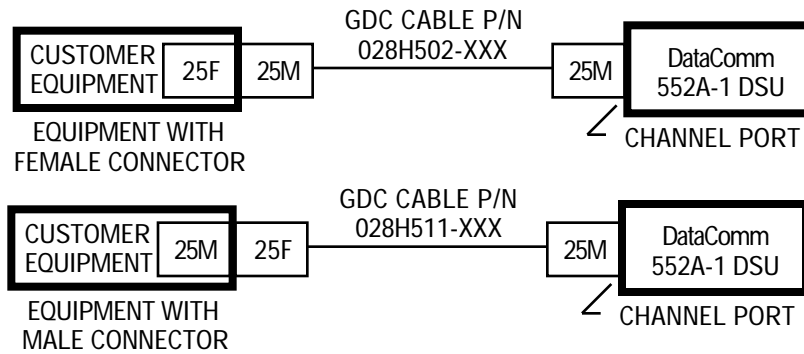

C. ALL HOUSINGS WITH AN EIA-530 INTERFACE

FIGURE 2-12. CHANNEL PORT INTERFACE CABLE APPLICATIONS (Sheet 1 of 2)

INSTALLATION

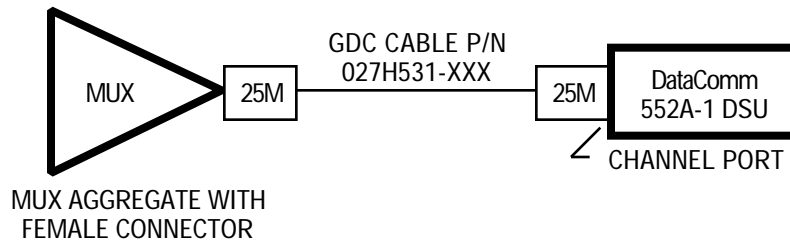

D. ALL HOUSINGS WITH AN RS-422 INTERFACE

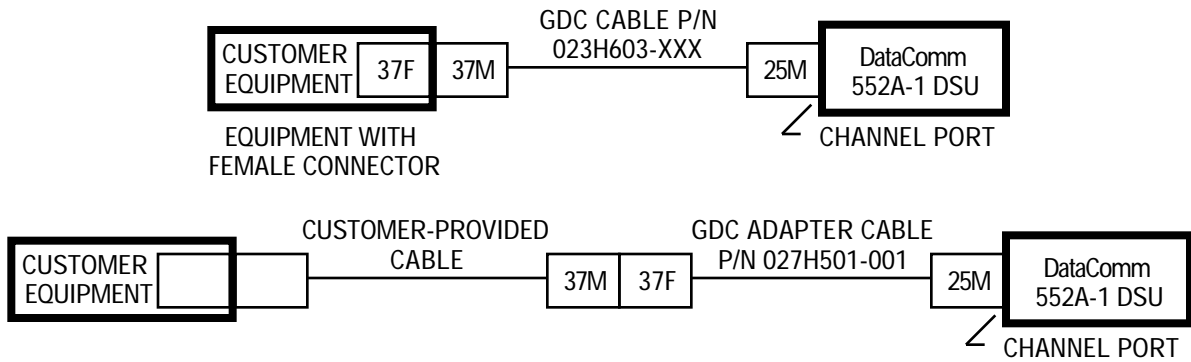

E. ALL HOUSINGS WITH AN RS-449 INTERFACE

FIGURE 2-12. CHANNEL PORT INTERFACE CABLE APPLICATIONS (Sheet 2 of 2)

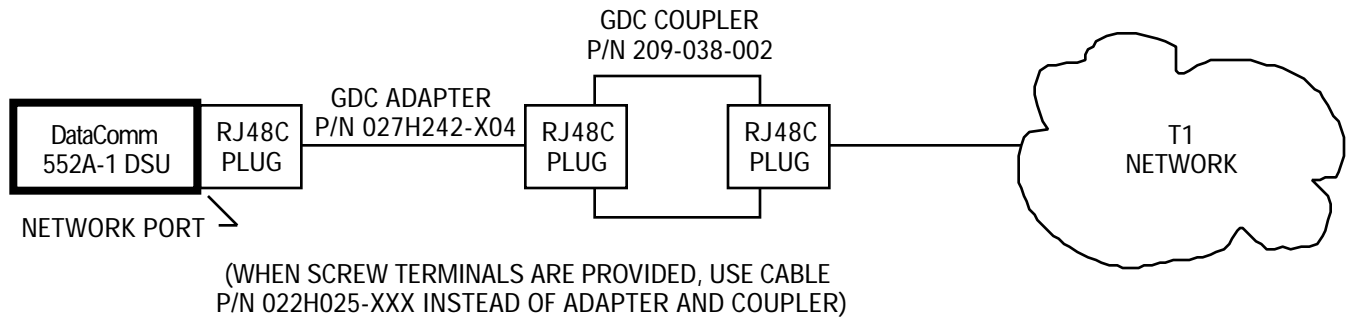

A. DataComm SHELF

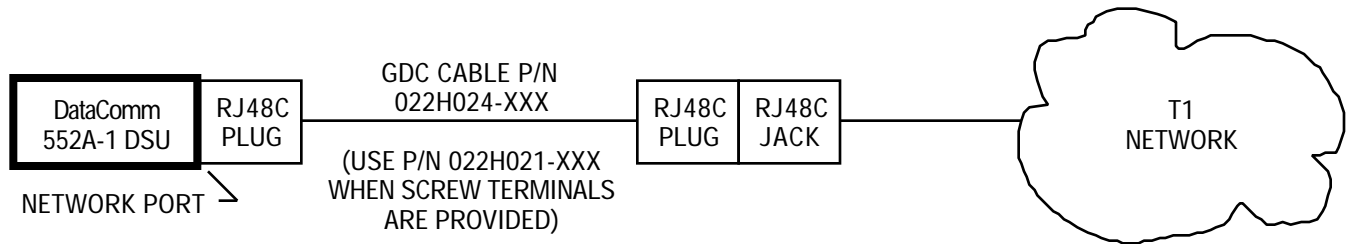

B. ALL OTHER HOUSINGS

FIGURE 2-13. NETWORK PORT INTERFACE CABLE APPLICATIONS

INSTALLATION

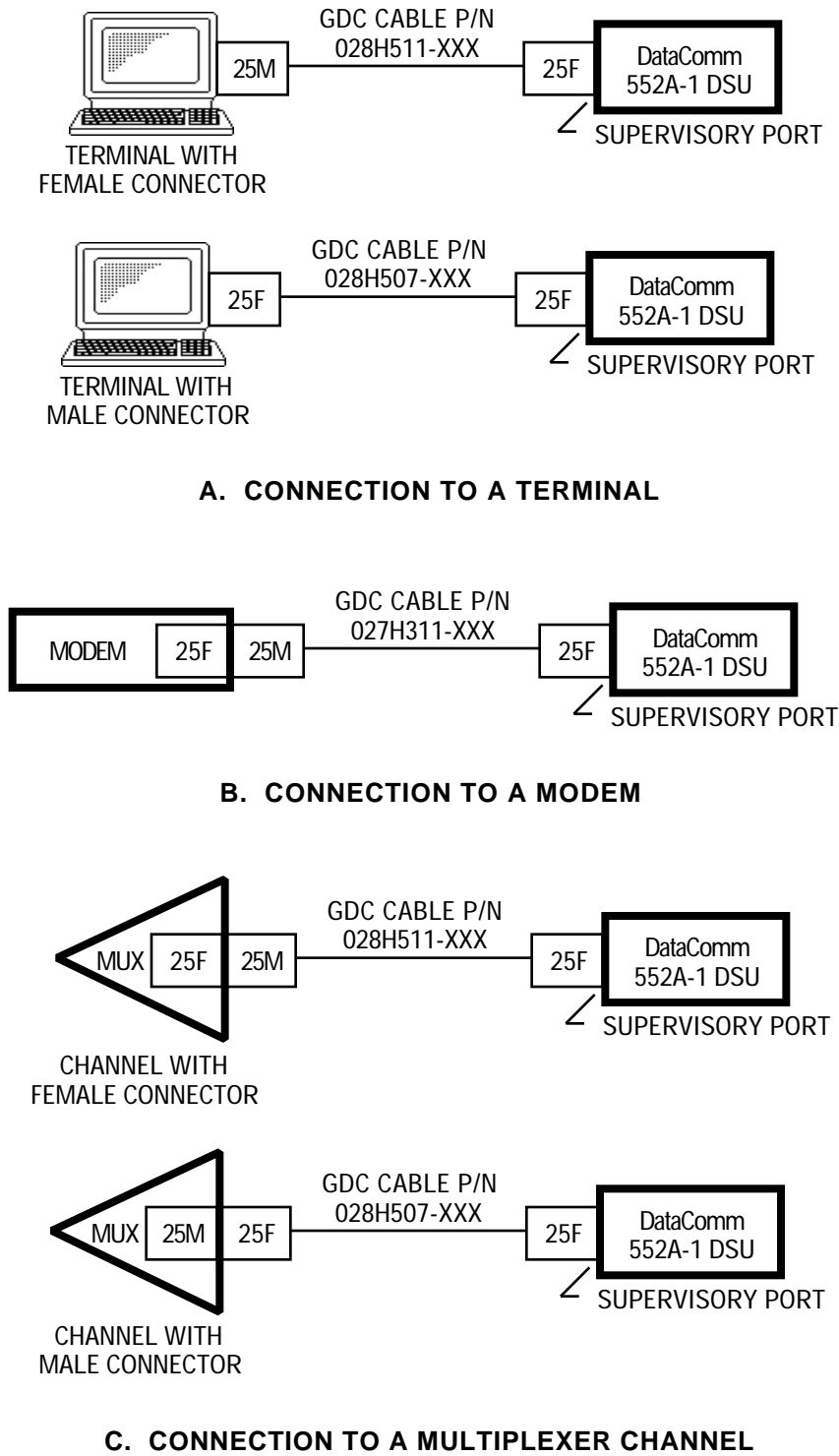

FIGURE 2-14. SUPERVISORY PORT INTERFACE CABLE APPLICATIONS

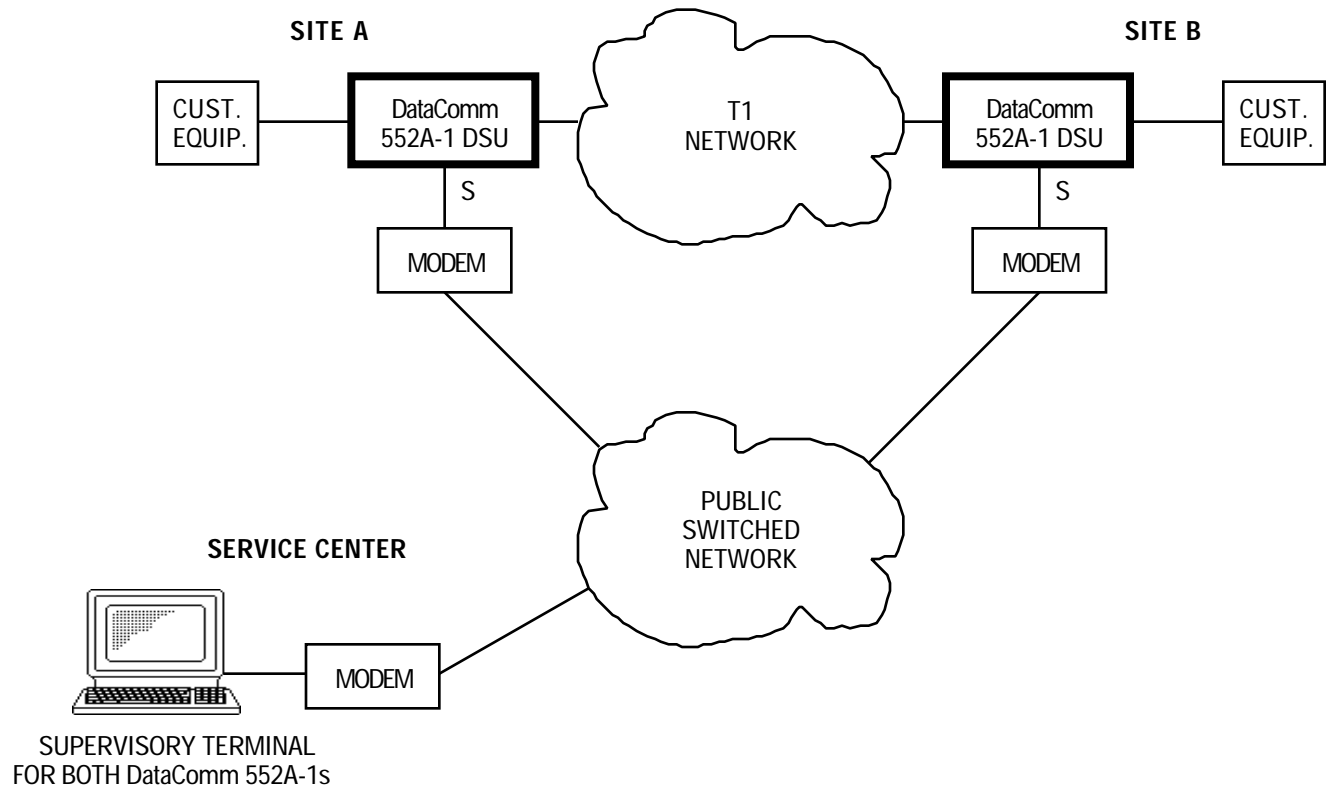

FIGURE 2-15. SUPERVISORY TERMINAL MODEM APPLICATION

INSTALLATION

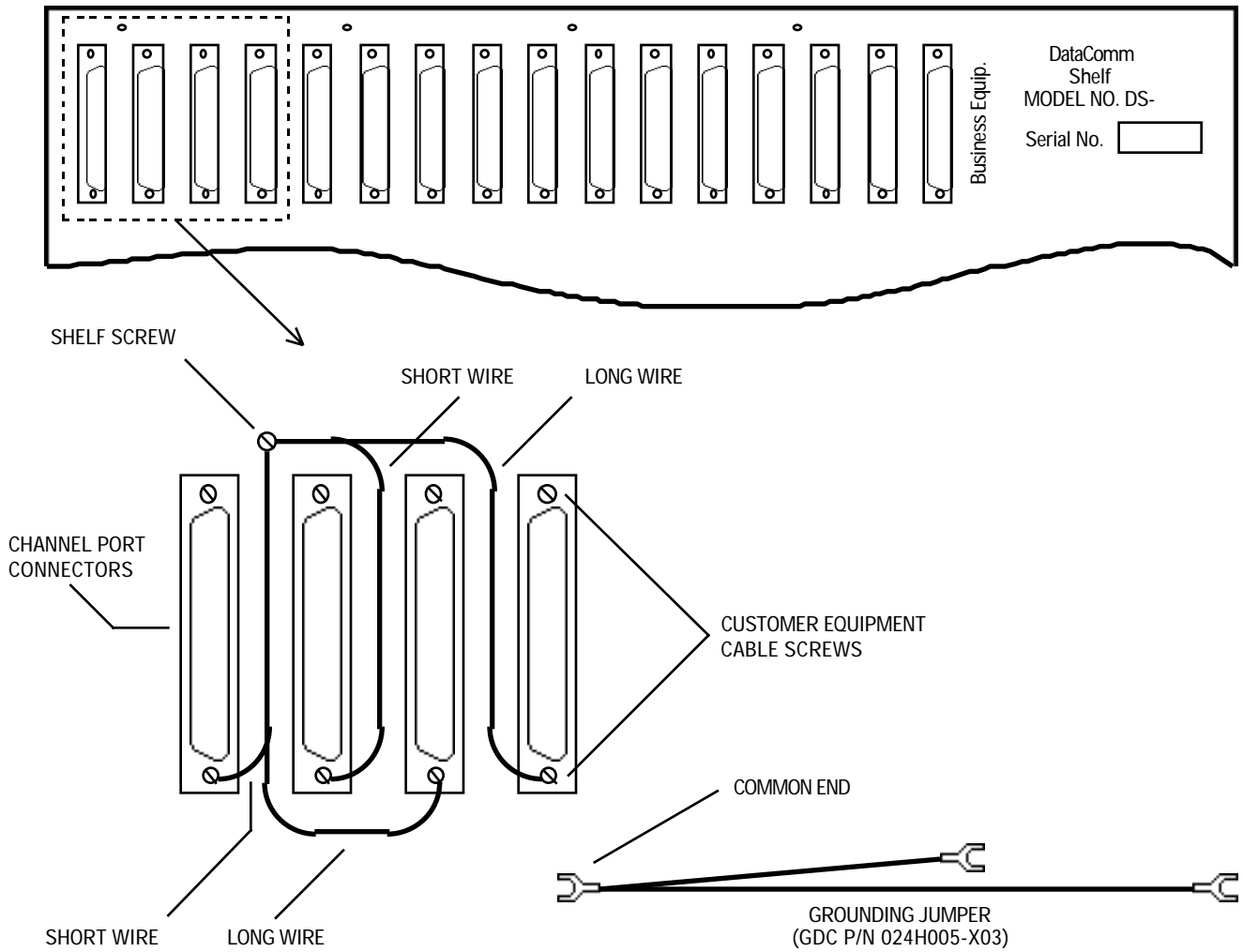

FIGURE 2-16. GROUNDING DataComm SHELF CABLES

SECTION 3

OPERATION

OVERVIEW

This section describes the front panel indicators, test jacks, and switches of the DataComm 552A-1 V1.1, and the operation of the Supervisory terminal.

FRONT PANEL INDICATORS, TEST JACKS, AND SWITCHES

Figures 3-1, 3-2, and 3-3 illustrate the DSU front panel indicators, test jacks, and switches, and explain the function of each. The upper half of the front panel provides DSU (or customer equipment) functions and the lower half provides CSU (or network) functions. Use of the test jacks and switches is further detailed in Section 4.

SUPERVISORY TERMINAL OPERATING PROCEDURES

The Supervisory terminal is used to configure, test, and maintain the DSU to which it is connected. It is also used to monitor the network Performance Reports provided by the Central Office. The functions of the Supervisory terminal are menu-oriented: there is a Main Menu which provides access to the diagnostics, configuration, and maintenance menus or screens (see Table 3-1). Each screen displays current data and allows changes to be made to the data. Thus, the user steps through the menus until the desired screen is displayed, and reviews or changes the data for individual fields.

Accessing a DSU

The Supervisory terminal is typically co-located and used with a single DSU, as shown in Figure 1-1. However, it can be located and used remotely, and it can be used to access more than one DSU. These applications utilize modems or PMC-100 Performance Monitor Cards, or both, to provide this access. Once the Supervisory terminal is communicating with the DSU, its operation is the same regardless of the means used to connect to it. That is, the Supervisory terminal appears to be connected directly to the DSU. The following paragraphs describe the procedures used to access the DSU.

OPERATION

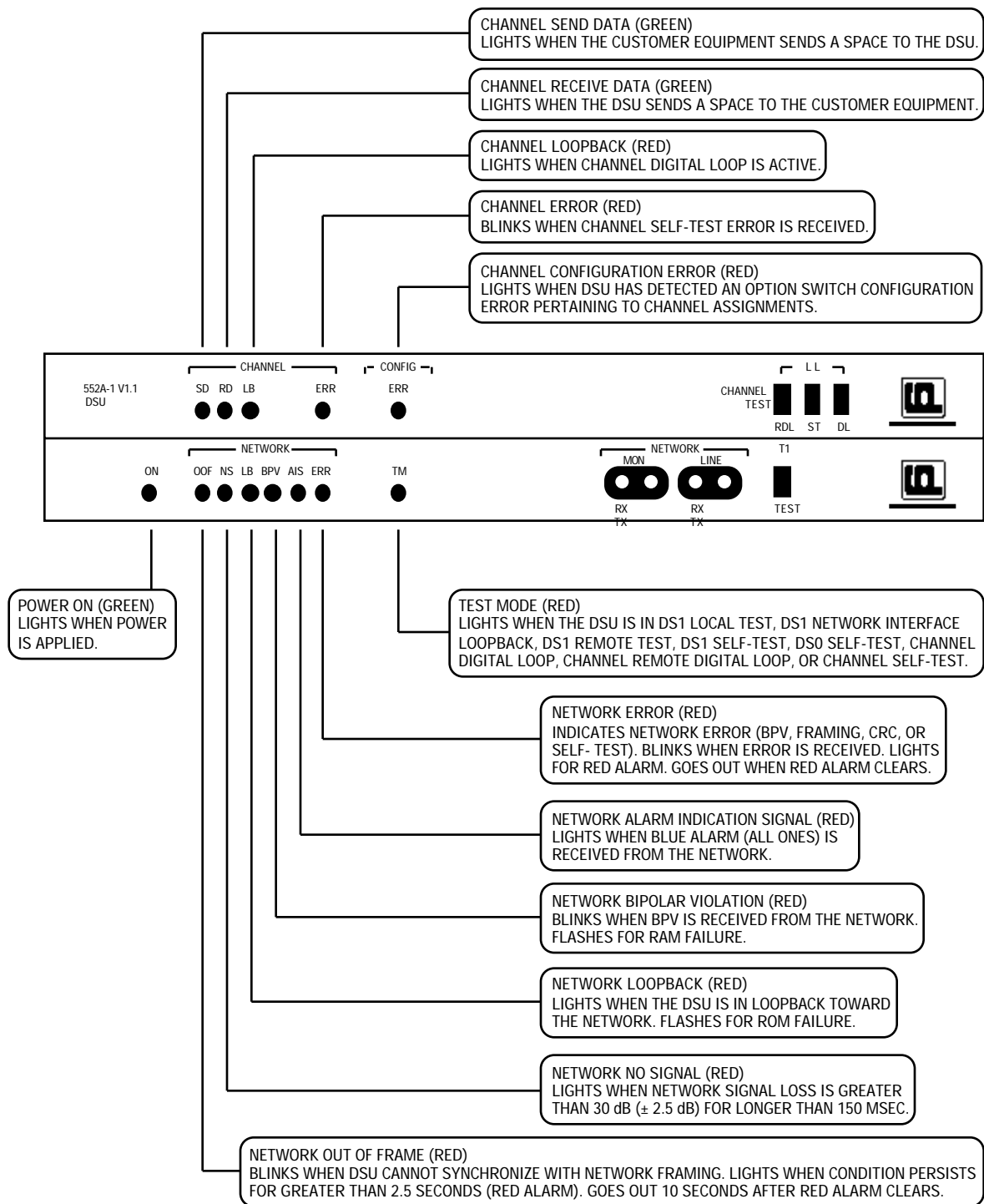
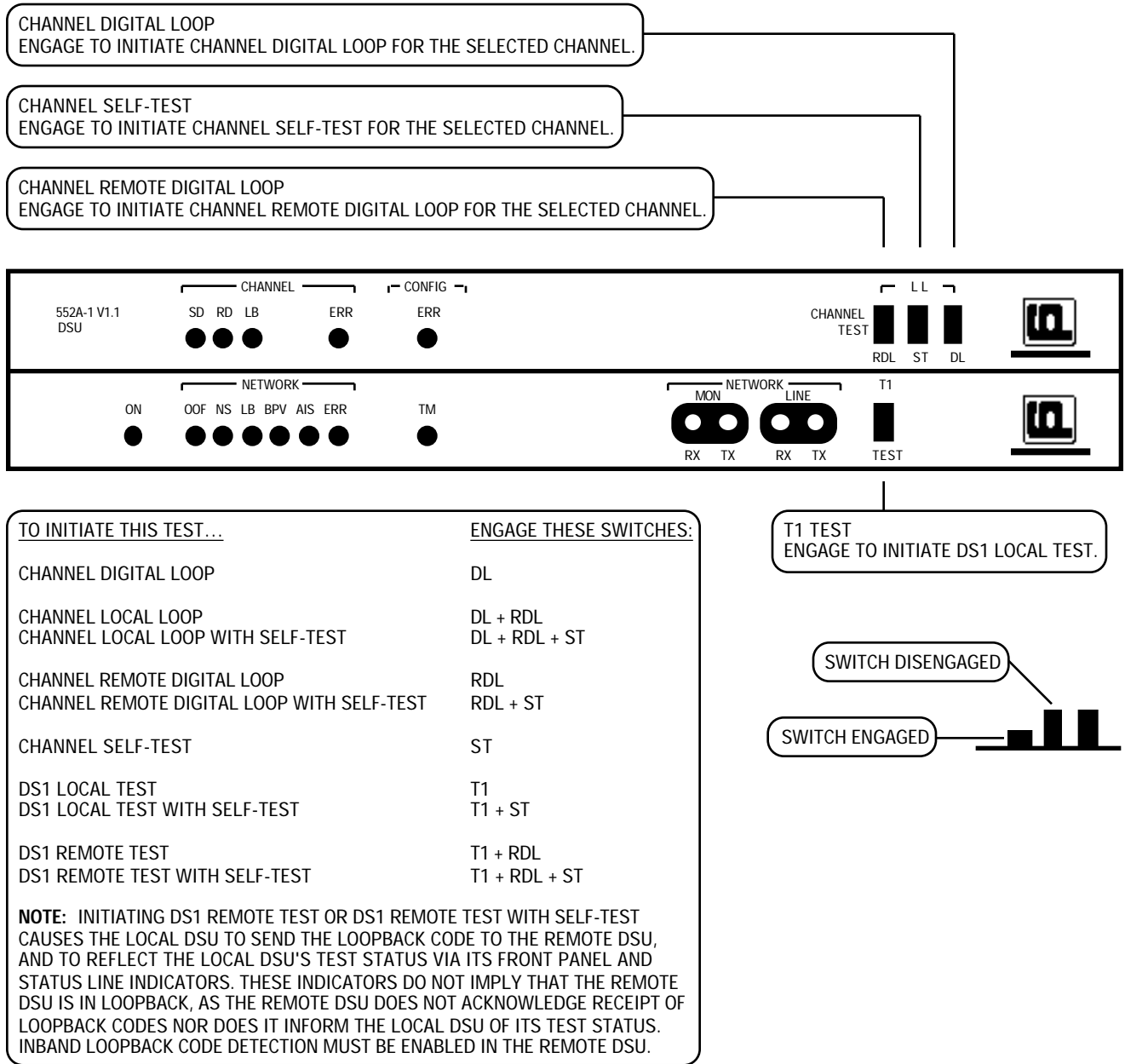

FIGURE 3-1. FRONT PANEL INDICATORS



NOTE: USE OF THESE SWITCHES MAY BE INHIBITED, DEPENDING ON SELECTION OF THE FRONT PANEL SWITCHES OPTION.

FIGURE 3-2. FRONT PANEL ACCESS TEST JACKS

OPERATION

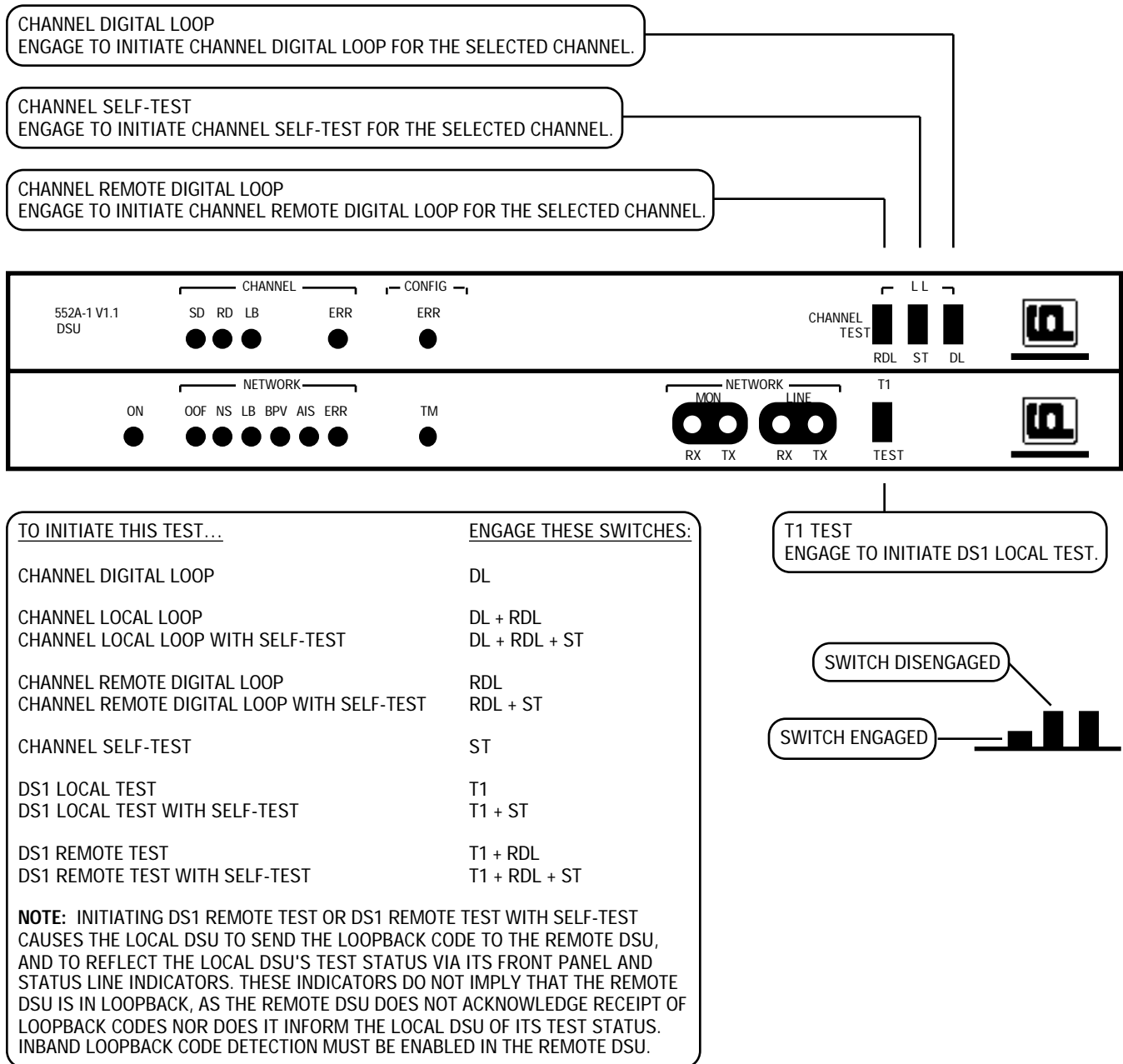

NOTE: USE OF THESE SWITCHES MAY BE INHIBITED, DEPENDING ON SELECTION OF THE FRONT PANEL SWITCHES OPTION.

FIGURE 3-3. FRONT PANEL SWITCHES

TABLE 3-1. MENU ORGANIZATION

Menu or Screen Name	Major Functions
MAIN MENU	Access other menus and screens
CHANNEL DIAGNOSTICS screen	Perform diagnostics on the channel
DS0 DIAGNOSTICS screen	Perform diagnostics on any DS0 (1 to 24)
T1 DIAGNOSTICS menu	Access reports or perform network-side diagnostics
T1 ALARM HISTORY screen	Display error counts
TWENTY-FOUR HOUR REPORTS menu	Access reports for the past twenty four hours
LOCAL USER TWENTY-FOUR HOUR REPORT screen	Display the user register set for the local DSU
REMOTE USER TWENTY-FOUR HOUR REPORT screen	Display the user register set for the remote DSU
REMOTE NETWORK TWENTY-FOUR HOUR REPORT screen	Display network register set for the remote DSU
SCHEDULED PERFORMANCE REPORT screen	Display errors for the past four seconds
CSU SELF TEST screen	Perform a self-test on the unit
LOOPBACKS screen	Perform network-side diagnostics
RECEIVE LEVEL screen	Display LBO setting and network-side signal level
CSU CONFIGURATION screen	Configure network options
CHANNEL CONFIGURATION screen	Configure options for the channel
MAINTENANCE screen	Set the date and time

MODEM APPLICATION

A typical application providing remote access is illustrated in Figure 1-2. To access a DSU, place a normal data call from the terminal location to the desired DSU location. After the data connection is made, use the terminal as you would when it is connected directly (described below). If you placed the call using the terminal, be sure to place the modem in data mode.

PMC-100 APPLICATION

PMC-100s provide enhanced network control and allow one Supervisory terminal to be easily shared among all DSUs in the network, as shown in Figures 1-3 through 1-6. Each DSU must have a unique identification, or network address, assigned during DSU configuration. (One PMC-100 is configured as the master and it is the one through which you access any DSU in the network.) To access a DSU once the Supervisory terminal is connected to the master PMC-100 (either directly or via modems) and the PERFORMANCE MONITOR menu is displayed:

1. Press N to select the NETWORK ELEMENT ACCESS screen.
2. Enter the three-digit address (000 to 255) of the desired DSU, then press the RETURN () key. This address is sent to all DSUs, but only the one assigned this address responds. If the DSU does not respond, the terminal displays the message No Response at the bottom of the screen. If you entered an incorrect address, the terminal displays the message Invalid Address at the bottom of the screen. Enter the correct address.
3. The Supervisory terminal is communicating with the DSU, and the DSU displays the log-on screen and its address (at the bottom of the

OPERATION

screen). Use the terminal as you would when it is connected directly (described below).

To access the master PMC-100 from a DSU, at any time, press the control key and the P key (for PMC-100) simultaneously. This is abbreviated as <Ctl>P.

NOTE

Do not attempt to access another DSU or the master PMC-100 while a DSU is waiting for confirmation of your last entry (indicated by the prompt Are You Sure? (Y/N) displayed at the bottom of the screen). If you do, you must repeat the process of accessing it.

Refer to the PMC-100 manual for additional PMC-100 operating instructions.

Soft Configuration Privileges Option

The Soft Configuration Privileges option (selected with option switch S4-6) provides control over using the Supervisory terminal to configure the DSU and to perform diagnostics. A DSU with Full Control privileges (sometimes called a master DSU) allows unrestricted configuration and diagnostics via the Supervisory terminal, while a DSU with Monitor privileges (sometimes called a slave DSU) gives the user the ability to separately control these privileges (depending on the Supervisory terminal communication path). There are two means of communication between the Supervisory terminal and a DSU's Supervisory port:

- ***In-band communication*** — the primary means of communicating with the DSU, utilizing PMC-100s and a dedicated multiplexer channel (i.e., a permanent virtual circuit, or PVC). In-band communication is intended for monitoring the DSU's performance reports and performing other non-disruptive diagnostics and maintenance functions. A DSU configured for Monitor privileges, when accessed via in-band communication, restricts Supervisory privileges to monitor only, preventing configuration changes and diagnostics. A typical in-band communication path is illustrated in Figure 2-5.
- ***Out-of-band communication*** — the alternate means of communicating with the DSU, that does not depend on the T1 link to the DSU. Out-of-band communication with the DSU is typically made via modems or a Supervisory terminal co-located with the DSU. It is intended for performing diagnostics that would disrupt in-band communication (such as a loopback) and for accessing the DSU when a T1 link failure prevents in-band communication. A DSU configured for Monitor privileges, when accessed via out-of-band communication, gives the user the ability to separately control Supervisory privileges. A typical out-of-band communication path is illustrated in Figure 2-6.

CAUTION

You must use only out-of-band communication for performing diagnostics that would disrupt in-band com-

munication and result in inaccurate data on the terminal or complete loss of communication.

The Log-On Screen

When you access the DSU, or on DSU power-up, the DSU log-on screen is displayed (see Figure 3-4), with the following information:

- system date (DD-MMM-YY)
- system time (HH:MM and A [AM] or P [PM])
- firmware revision level (REV: revision)
- status of the DSU non-volatile memory (NVRAM: status)
- status of the DSU random access memory (RAM: status)
- status of the DSU read-only memory (ROM: status)
- DSU address number (DSU: 3-digit address)
- Supervisory Privilege Level (Privilege: level)

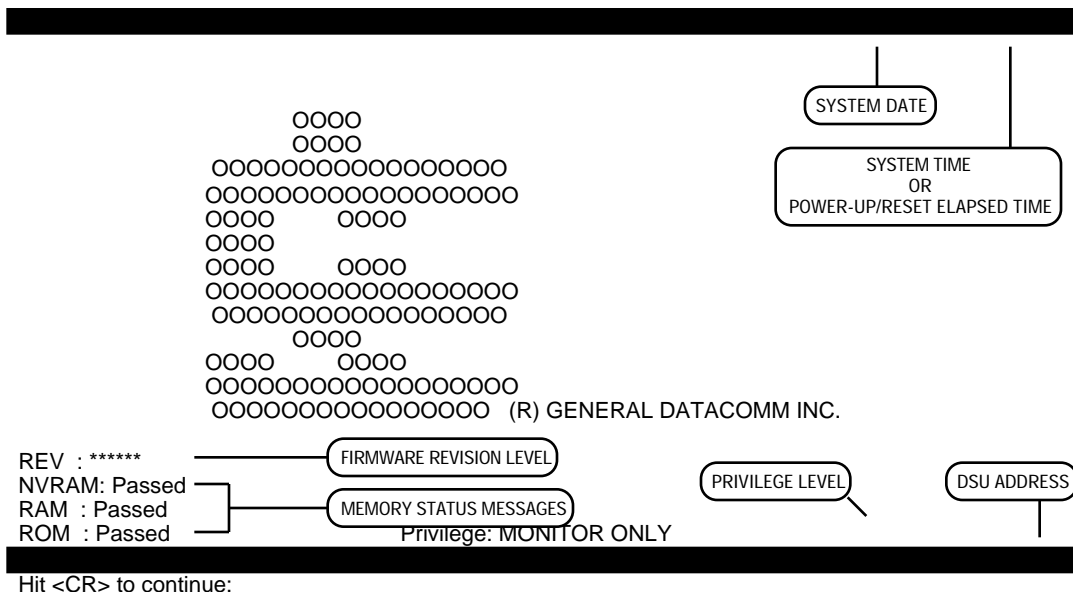

FIGURE 3-4. LOG-ON SCREEN

OPERATION

Until it is set (using the Set Date function of the Maintenance screen), the date displayed is the firmware release date. After being set, it is the true system date.

Until it is set (using the Set Time function of the Maintenance screen), the time displayed is the time elapsed since the DSU was powered up. After being set, it is the true system time.

The firmware revision level identifies the firmware version (the system software contained in EPROMs).

A memory status message is Passed (message is on steady) or Failed (message is flashing), and indicates whether the memory passed certain tests. A RAM failure is also indicated by flashing front panel indicator BPV, and a ROM failure is also indicated by flashing front panel indicator NETWORK LB. Any failed memory should be considered a potentially serious problem and the pc cards should be replaced. Use of the Supervisory terminal is prohibited during a failed memory condition. Supervisory terminal operation may be restored and the memory problem may be temporarily corrected by powering off the DSU and then powering it on. If the problem cleared, the DSU and Supervisory terminal should be operational.

The DSU address number (000 to 255) identifies the DSU to which you are connected. This address is defined by option switches S5-1 to S5-8.

Press RETURN to display the Main Menu.

Display Information

Each menu and screen (except the log-on screen) displays the following information (see Figure 3-5):

- current menu or screen name
- system date and time
- status line
- DSU address number

The status line reflects the status of the front panel indicators and switches, and provides additional information. For front panel switches, a period (.) indicates that the switch is disengaged, and an X indicates that it is engaged. For front panel indicators, a period indicates normal or inactive status, and an X (or other character) indicates abnormal or active status. The meanings of the status line indicators are described in Table 3-2.

Using the Keyboard

To select any menu, screen or function displayed on the current screen, simply press the letter shown to the left of its name. To select the DS0 Diagnostics menu from the Main Menu, for example, press D. The DSU may request confirmation of an entry by displaying the message Are You

Sure? (Y/N) at the bottom of the screen. Press Y to confirm the entry and continue, or press N to stop. In all menus and screens, keyboard entries are not case-sensitive: it does not matter whether the Supervisory terminal is in lower-case or upper-case mode (all entries are converted to upper-case). If you press an invalid key (one that is not used in the current screen) or enter a value that is out of range, the terminal beeps and an error message is displayed at the bottom of the screen. Try a valid entry.

To return to the previous menu, press E (exit) or <ESC> (escape).

The Main Menu

The Main Menu (see Figure 3-5) provides access to the diagnostics, configuration, and maintenance menus or screens.

NOTE

In Soft Configuration Mode, Supervisory terminal configuration overrides option switch configuration. In Hard Configuration Mode, switch configuration overrides terminal configuration, and the terminal reads CSU configuration but not channel configuration.

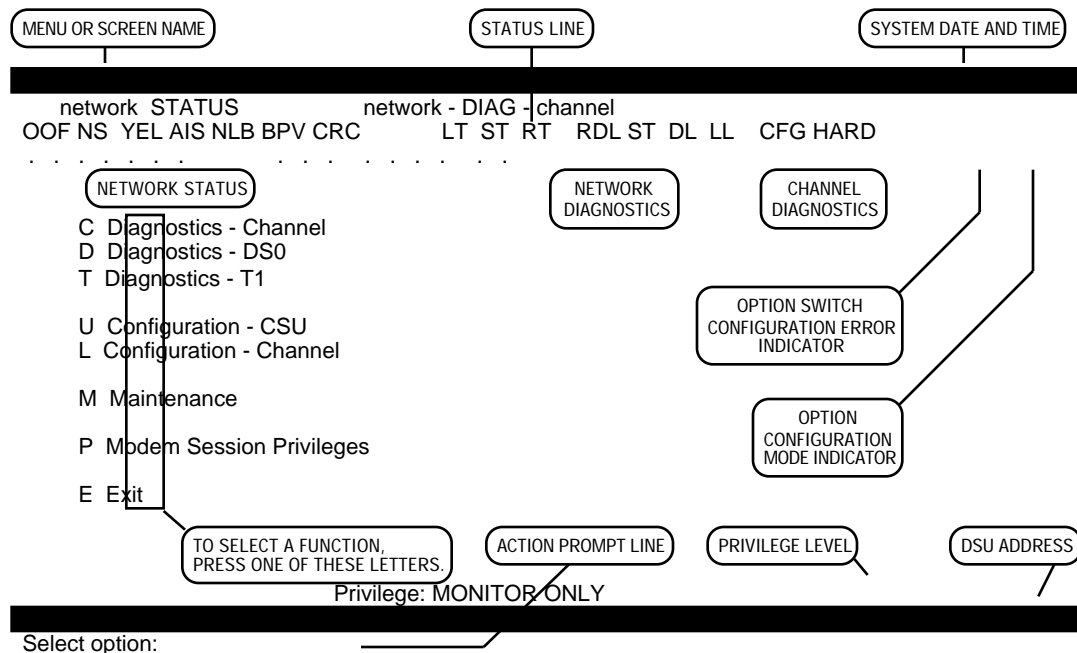

FIGURE 3-5. MAIN MENU

OPERATION

Privilege Level

Privilege Level indicates the configuration and diagnostics privileges given to a Supervisory terminal. With FULL CONTROL privileges you can make configuration changes and perform diagnostics. The Monitor privilege levels, dependent on the Supervisory terminal communication path, include MONITOR ONLY (no configuration or diagnostics), CONFIGURATION ONLY (no diagnostics), and DIAGNOSTICS ONLY (no configuration). A DSU configured for Monitor privileges, when accessed via in-band communication, restricts Supervisory privileges to monitor only, preventing configuration and diagnostics. When accessed via out-of-band communication, it gives the user the ability to separately control Supervisory configuration and diagnostics privileges.

When you access the Main Menu of a DSU configured for Monitor privileges, it prompts you for the communication path you are using:

Supervisory Terminal Access - Enter I for Inband or M for Modem:

If you are using in-band communication, press I. Privilege Level displays MONITOR ONLY and you are prevented from making configuration changes and performing diagnostics. If you are using out-of-band communication (i.e., the Supervisory terminal is connected either directly to the DSU or through modems), press M. Privilege Level displays MONITOR ONLY, and adds the Modem Session Privileges function to the Main Menu. Access the Modem Session Privileges screen (described below) to control Supervisory configuration and diagnostics privileges.

The Modem Session Privileges Screen

The Supervisory terminal can be used to control configuration and diagnostic privileges for a DSU configured for Monitor privileges when accessed via out-of-band communication (i.e., the Supervisory terminal is connected either directly to the DSU or through modems). Figure 3-6 illustrates the functions available through the MODEM SESSION PRIVILEGES screen.

Configuration

This function controls Supervisory configuration privileges. Select INHIBIT (the default setting) to prevent configuration changes during this session, or ENABLE to allow them. To toggle this function, press C.

Diagnostics

This function controls Supervisory diagnostic privileges. Select INHIBIT (the default setting) to prevent diagnostic during this session, or ENABLE to allow them. To toggle this function, press D.

The DSU updates Privilege Level, displaying one of four levels:

- MONITOR ONLY — configuration and diagnostics inhibited
- CONFIGURATION ONLY — configuration enabled, diagnostics inhibited
- DIAGNOSTICS ONLY — configuration inhibited, diagnostics enabled

- FULL CONTROL — configuration and diagnostics enabled

NOTE

The Supervisory privileges you select apply only for the duration of the current session. When you return to the log-on screen, the Privilege Level defaults to MONITOR ONLY.

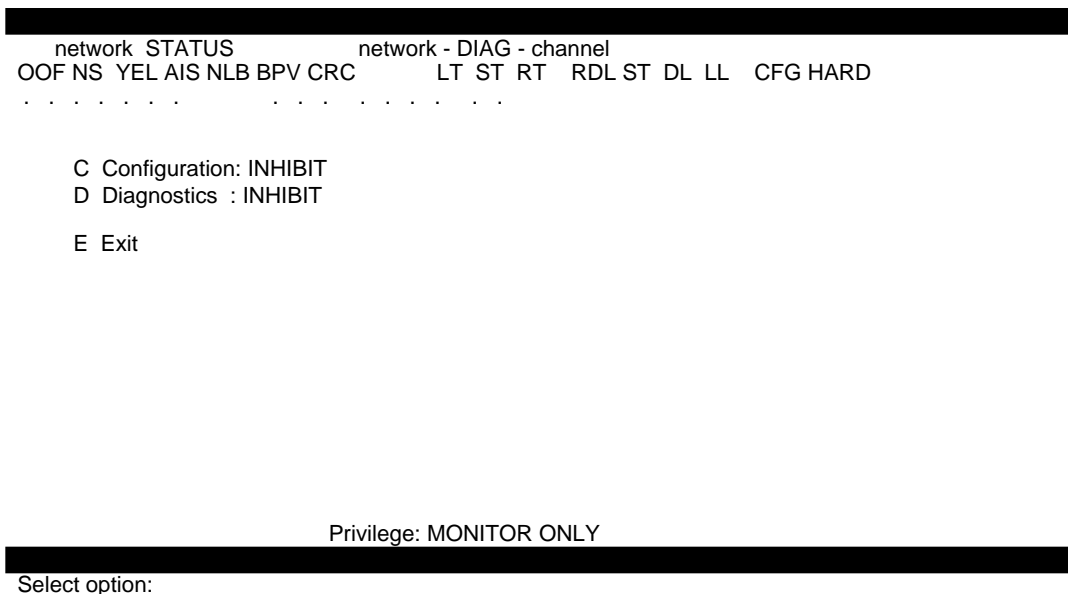

FIGURE 3-6. MODEM SESSION PRIVILEGES SCREEN

TABLE 3-2. STATUS LINE INDICATORS

Status Line Indicator	Equivalent Front Panel	Description
Network Indicators		
OOF	OOF	<i>Network Out of Frame</i> — indicates whether the DSU is (.) or is not (X) synchronized with network framing.
NS	NS	<i>Network No Signal</i> — indicates whether the DSU is (.) or is not (X) receiving a network signal (a signal with loss greater than 30 dB [\pm 2.5 dB] for longer than 150 milliseconds is considered no signal).
YEL	n/a	<i>Yellow Alarm</i> — indicates whether the DSU is (X) or is not (.) receiving a Yellow alarm from the network. In response to receiving a Yellow alarm from one side, the DSU transmits a Yellow alarm to the other side, in the proper format (D4 or ESF).
AIS	AIS	<i>Alarm Indication Signal</i> — indicates whether the DSU is (X) or is not (.) receiving an AIS from the network (a keep alive signal of framed 1s filling the unused bandwidth). In response to receiving an AIS from one side, the DSU returns a Yellow alarm, and transmits an AIS to the other side.
NLB	LB	<i>Network Loopback</i> — indicates whether the DSU is (X) or is not (.) in a DS1 loopback test toward the network.
BPV	BPV	<i>Network Bipolar Violation</i> — indicates whether the DSU has (X) or has not (.) received a BPV.
CRC	ERR	<i>Cyclic Redundancy Check</i> — indicates whether the DSU has (X) or has not (.) received a CRC error.
Diagnostics Indicators		
Network		
LT	TM	<i>Local Test</i> — indicates whether front panel switch T1 TEST is engaged (X) or disengaged (.). Also indicates whether DS1 Local Test is (X) or is not (.) active.
ST	TM	<i>Self-Test</i> — indicates whether DS1 Self-Test (1) or DS0 Self-Test (0) is or is not active (.).
RT	TM	<i>Remote Test</i> — indicates whether DS1 Remote Test is (X) or is not (.) active.
Channel		
RDL	TM	<i>Remote Digital Loopback</i> — indicates whether Channel Remote Digital Loop is (X) or is not active (.).
ST	CHANNEL ERR, TM	<i>Self-Test</i> — indicates whether Channel Self-Test is (X) or is not active (.).
DL	CHANNEL LB, TM	<i>Digital Loopback</i> — indicates whether Channel Digital Loop is (X) or is not active (.).
LL	CHANNEL LB, TM	<i>Channel Local Loopback</i> — indicates whether Channel Local Loop is (X) or is not active (.).
Other Indicators		
CFG	CONFIG ERR	<i>Configuration Error</i> — indicates whether the DSU has (X) or has not (.) detected an option switch configuration error pertaining to channel assignments (Starting DS0 Number, Channel Data Rate, and Alternate DS0 options) while in Hard Configuration Mode.
HARD	n/a	<i>Configuration Mode</i> — indicates whether Configuration Mode is Hard (X) or Soft (.).
NOTE: The normal or inactive status is indicated by a period (.), while an abnormal or active status is indicated by an X or other letter or number.		

The Channel Diagnostics Screen

The Supervisory terminal can be used to control several channel-level (customer equipment) diagnostic tests. Once started, these tests must be stopped via the Supervisory terminal: they cannot be stopped via the front panel. Figure 3-7 illustrates the functions available through the CHANNEL Diagnostics screen.

Ch Loop Status

This displays the test that is running on the channel: Remote Digital Loop or Digital Loop. When no test is running, this displays NONE.

Self Test Status

This displays the Channel Self-Test status: NO ERRORS (active, with no errors detected), ERRORS - Proceed to DS0 test (active, with errors detected), or OFF (inactive).

```
network STATUS          network - DIAG - channel
OOF NS YEL AIS NLB BPV CRC      LT ST RT  RDL ST DL LL  CFG HARD
. . . . .                  . . . . .

Ch Loop Status : NONE

Self Test Status: OFF

R Remote Digital Loop
D Digital Loop
L Local Loop

I Initiate Self Test
T Terminate Self Test

E Exit

Privilege: FULL CONTROL

Select option:
```

FIGURE 3-7. CHANNEL DIAGNOSTICS SCREEN

OPERATION

Remote Digital Loop

This function controls the Channel Remote Digital Loop described in Section 4. There is a delay (described below) after you start or stop this test. During intervals before and after the actual test, the DSU is required to send in-band loopback codes to the remote DSU. This test can also be used in conjunction with Channel Self-Test to control the Channel Remote Digital Loop with Self-Test described in Section 4. The status line RDL and front panel TM indicators reflect the status of this test. To start or stop this test, press R.

The DSU uses either fixed or scrambled loopback codes. The fixed 7-bit binary loop-up code that puts the channel in loopback is "1100000" and the loop-down code that takes it out of loopback is "1110000," with a delay of five seconds. The scrambled code is generated by the polynomial $1 + x^3 + x^7$, similar to that used in PN-127, and the code is sent for two seconds. In the event the DSU does not loop up or loop down, it is likely there are channel errors. The type of code is set via option switch S12-1, or via the RDL Inband Code function on the Channel Diagnostics screen, and must be the same for both DSUs.

NOTE

Initiating DS1 Remote Test causes the local DSU to send the loopback code to the remote DSU, and to reflect the local DSU's test status via its front panel and status line indicators. These indicators do not imply that the remote DSU is in loopback, as the remote DSU does not acknowledge receipt of loopback codes nor does it inform the local DSU of its test status. In-Band DS1 Loopback Code Detection must be enabled in the remote DSU.

Digital Loop

This function controls the Channel Digital Loop described in Section 4. The status line DL and front panel CHANNEL LB and TM indicators reflect the status of this test. To start or stop this test, press D.

Local Loop

This function controls the Channel Local Loop described in Section 4. The status line LL and front panel CHANNEL LB and TM indicators reflect the status of this test. To start or stop this test, press L.

Initiate Self Test

This function starts the Channel Self-Test, generating and verifying a 511-bit test pattern, described in Section 4. This test can also be used in conjunction with Channel Remote Digital Loop to control the Channel Remote Digital Loop with Self-Test described in Section 4. The status line channel ST and front panel CHANNEL ERR and TM indicators reflect the status of this test. To use this function, press I.

Terminate Self Test

This function stops the Channel Self-Test. To use this function, press T.

**The DS0
Diagnostics Screen**

The Supervisory terminal can be used to control several DS0-level diagnostic tests. Figure 3-8 illustrates the functions available through the DS0 Diagnostics screen. Only one test, on one of the 24 DS0s, can be performed at a time. A DS0 diagnostic affects only the selected DS0.

CAUTION

All DS0 diagnostic functions can be selected only via the Supervisory terminal, and those selected for the remote DSU must use out-of-band communications.

DS0 Channel Number

This function selects and displays the DS0 channel (1 to 24) on which the test is to be performed. The selection is retained when you exit this screen, and when the DSU is powered down. To use this function, press N and then enter the DS0 number.

CAUTION

The DS0 locations (1 to 24) at both ends must be known and properly selected. For DACS-based systems, the originating and terminating DS0 locations may be different. For point-to-point private lines (e.g., non-DACS), they are the same.

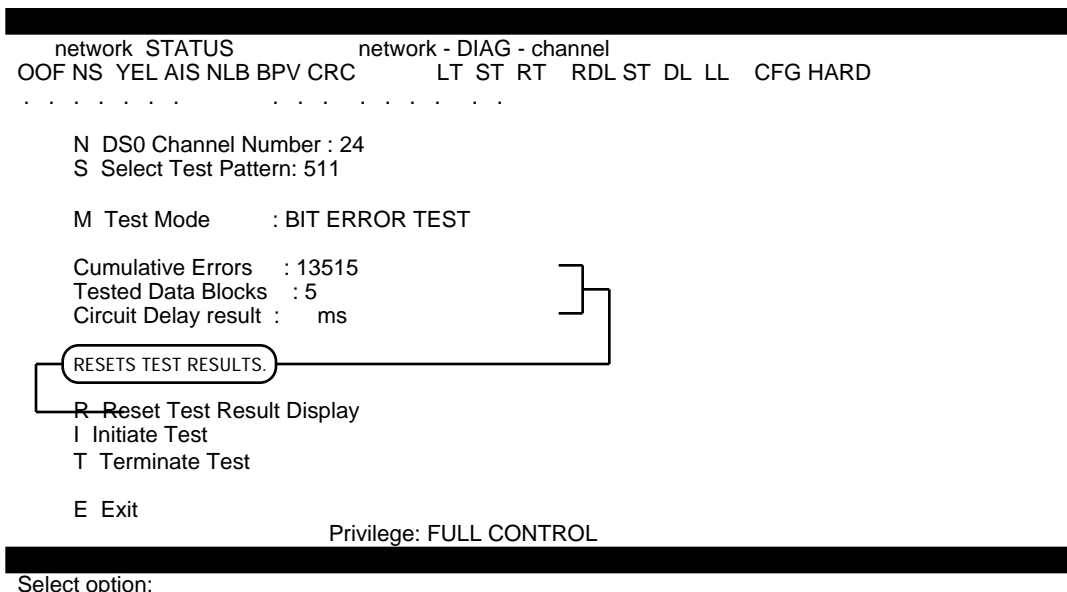

FIGURE 3-8. DS0 DIAGNOSTICS SCREEN

OPERATION

Select Test Pattern

This function selects and displays one of the following test patterns, to be used in the BIT ERROR TEST mode:

511 511-bit test pattern
2047 2047-bit test pattern
QRS Quasi-Random Signal (QRS) test pattern

To step through the test patterns, press S. The test pattern selection is retained when you exit this screen, and when the DSU is powered down.

NOTE

- a. *Always select the same test pattern at both DSUs.*
- b. *For self-tests, the QRS test pattern is typically used instead of the 511- or 2047-bit test patterns.*

Test Mode

This function selects and displays one of the following test modes: LOOPBACK, BIT ERROR TEST, or DELAY TEST. To step through the test modes, press M. These modes are used alone or in combination (in a specific sequence) to perform the tests described in Section 4, as follows:

Test	Use This Mode at Remote DSU	... and Use This Mode at Local DSU
DS0 Circuit Delay Measurement	LOOPBACK	DELAY TEST
DS0 End-to-End Self-Test	BIT ERROR TEST	BIT ERROR TEST
DS0 Remote Test	LOOPBACK	n/a (uses customer data)
DS0 Remote Test with Self-Test	LOOPBACK	BIT ERROR TEST

Cumulative Errors

This displays the total errors counted (not the bit error rate) as an indication of circuit quality for tests using the BIT ERROR TEST mode. The maximum count is 59500. For all counts in excess of 59500, >59500 is displayed. For the DS0 End-to-End Self-Test, errors for the local-to-remote leg are displayed at the remote DSU, while errors for the remote-to-local leg are displayed at the local DSU (that is, test results are always displayed at the receiving end). (This field is displayed only when BIT ERROR TEST is selected.)

Tested Data Blocks

This displays the total number of blocks tested using the BIT ERROR TEST mode. The maximum count is 65536. Each block is 1 x 10⁵ (100,000) bits long. (This field is displayed only when BIT ERROR TEST is selected.)

Circuit Delay result

This displays the total round trip delay using the DELAY TEST mode. The delay is displayed in ms (milliseconds). For all delays in excess of 2 seconds (2,000 ms), NO CONNECTION is displayed. (This field is displayed only when DELAY TEST is selected.)

Reset Test Result Display

This function resets to 0 the test result displays (Cumulative Errors, Tested Data Blocks, and Circuit Delay result). To use this function, press R.

Initiate Test

This function starts the test. You cannot make any changes while the test is running, nor can you exit this screen, but you can stop the test at any time by pressing T (refer to Terminate Test). To use this function, press I.

NOTE

- a. *You cannot initiate a DS0 diagnostic while a DS1 diagnostic is in progress.*
- b. *The DS0 Circuit Delay Measurement Test stops at the local DSU automatically after computing the delay, but leaves the remote DSU in the LOOPBACK mode.*

Terminate Test

This function stops the test. To use this function, press T.

OPERATION

The T1 Diagnostics Menu

The Supervisory terminal can be used to monitor T1 link Performance Reports, display alarm counts, and perform diagnostics such as loopback tests. Figure 3-9 illustrates the screens and functions available through the T1 Diagnostics menu.

To keep track of and analyze network performance, the network needs error information based on intervals of 15 minutes, one hour and 24 hours, with a resolution generally of one second. For the purposes of generating reports for the network, time begins when the DSU is powered up: The times you see refer to the 24 hour period and 15 minute interval, not to the time of day. Most errors are logged over 15-minute intervals (there are four 15-minute intervals per hour and 96 15-minute intervals per 24 hour period). As time progresses, the errors for one interval become the errors for the next interval and are no longer updated: only the current interval is ever updated.

The DSU stores error information in two independent register (memory) sets: the network register set and the user register set. The network register set is provided for the Central Office to retrieve and clear. The user register set is what you see displayed in the various diagnostics screens, but it is not affected when the Central Office clears the network register set. Therefore, the two register sets will not contain the same error information after the Central Office clears the network register set.

```
network STATUS          network - DIAG - channel
OOF NS YEL AIS NLB BPV CRC      LT ST RT  RDL ST DL LL  CFG HARD
. . . . .
```

- A Alarm History
- T Twenty-Four Hour Reports
- C Scheduled Performance Report
- S Self Test
- L Loopback
- R Receive Level

- E Exit

```
Privilege: FULL CONTROL
```

```
Select option:
```

FIGURE 3-9. T1 DIAGNOSTICS MENU

The errors reported by the DSU are:

- ESF error events — An Extended Superframe Format (ESF) error event is an ESF frame that contains a CRC-6 error event or an OOF state, or both. ESF error events are processed to derive ESs, BESs and SESs.
- Errored second (ES) — An ES is a second with one or more ESF error events.
- Bursty errored second (BES) — A BES is a second with more than one but less than 320 CRC-6 error events.
- Severely errored second (SES) — An SES is a second with 320 or more ESF error events, or with one or more OOF states. SESs are also processed to derive unavailable signal states.
- Unavailable signal state — An unavailable signal state is declared at the onset of 10 consecutive SESs. While in the unavailable signal state no ESs, BESs or SESs are counted. The unavailable signal state is cleared at the onset of 10 consecutive seconds with no SESs.
- Unavailable second (UAS) — A UAS is counted for every second the unavailable signal state exists.
- Loss of frame count (LOFC) — An LOFC is the accumulation of the number of times a loss of frame is declared.

How these errors are related and derived is shown in Figure 3-10.

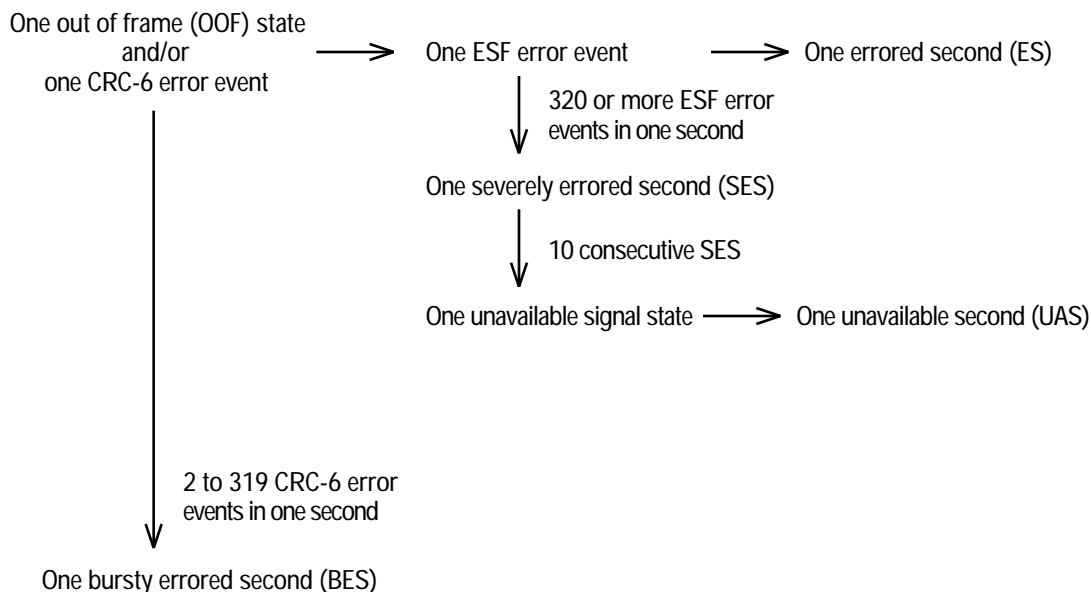

FIGURE 3-10. ERROR DESCRIPTION

OPERATION

T1 ALARM HISTORY SCREEN

This function displays the count (number of recorded events) of each of the listed errors that have been reported since the alarm history was cleared (initialized). The information is updated when you begin this function and when you press RETURN while this screen is displayed. The alarm counts are divided into three groups: MAJOR, MINOR and OTHER alarms, and are described below. To use this function, press A. Figure 3-11 illustrates the T1 Alarm HISTORY screen.

When you use the PMC-100 to perform the Scan Network Elements function, a DSU with alarm conditions reports to the PMC-100 the number of Major and Minor Alarms but does not report specific alarms. You must review the T1 Alarm HISTORY screen to determine which alarms exist. The Network Out Of Frame (network OOF) and DSU Configuration Error (CFG) alarms appear on the status line. Because they indicate current status, they may have cleared by the time you go from the PMC-100's Scan Network Elements screen to the DSU reporting the alarm.

```
network STATUS          network - DIAG - channel
OOF NS YEL AIS NLB BPV CRC      LT ST RT  RDL ST DL LL  CFG HARD
. . . . .                . . . . .

Initialized: 31-DEC-92 03:34P  Count 1st Occurrence  Last Occurrence

MAJOR  Network Loss Of Signal: 1    04-FEB-91 01:25P 04-FEB-91 01:25P
       Network Out Of Frame : 1    31-DEC-92 01:26P 31-DEC-92 01:26P
       Alarm Indication      : 0
       Unavailable Sig. State: 1    04-FEB-91 01:25P 04-FEB-91 01:25P

MINOR  Received Yellow       : 0
       Excessive Zeros       : 0
       Low Average Density    : 0
OTHER  Bipolar Violations    : 38761 31-DEC-92 03:34P          31-DEC-92 03:34P
       CRC Errors             : 0
       Controlled Slips       : 0

I Initialize Alarm History
E Exit                               Privilege: FULL CONTROL

Select option:
```

FIGURE 3-11. T1 ALARM HISTORY SCREEN

Initialized

Displays the date (DD-MMM-YY) and time (HH:MM) that the alarm history was initialized using the Initialize Alarm History function.

Count

Displays the count (number of recorded events) of each of the listed errors that have been reported since the alarm history was initialized. The maximum count for any alarm is 65535, unless otherwise stated.

1st Occurrence

Displays the date (DD-MMM-YY) and time (HH:MM) of the first occurrence of the alarm (i.e., the first event since the alarm history was initialized). If the alarm is active at the time of initialization, this displays the date and time of the previous Last Occurrence.

Last Occurrence

Displays the date (DD-MMM-YY) and time (HH:MM) of the last occurrence of the alarm. If the alarm is active (indicated by flashing on and off) at the time of initialization, this date and time moves to 1st Occurrence.

MAJOR ALARMS

Network Loss Of Signal

A Loss of Signal (LOS) event occurs when the DSU senses an absence of network signal. A signal with loss greater than 30 dB (± 2.5 dB) for longer than 150 milliseconds is considered no signal. The status line and front panel NETWORK NS indicators reflect the current status of the network signal condition.

Network Out Of Frame

An Out Of Frame (OOF) event occurs when the DSU misses two out of four network framing bits. The counter increments by one, whether a single event or a persistent condition. The status line network OOF and front panel NETWORK OOF and NETWORK ERR indicators reflect the current status of DSU-to-network synchronization.

Alarm Indication

This is a count of the number of times the DSU receives an AIS (Alarm Indication Signal: a keep alive signal of continuous, framed 1s filling the unused bandwidth) from the network. The counter increments only when the alarm is removed. The status line and front panel NETWORK AIS indicators reflect whether the DSU is receiving an AIS.

Unavailable Signal State

An unavailable signal state event occurs when 10 consecutive SESs occur. An unavailable signal state ends when 10 consecutive seconds of data are

OPERATION

processed and no SESs occur. For every second an unavailable signal state exists, a UAS results.

MINOR ALARMS

Received Yellow

This is a count of the number of times the DSU receives a Yellow alarm (a remotely detected failure) from the network. The counter increments only when the alarm is removed. The status line YEL indicator reflects whether the DSU is receiving a Yellow alarm.

Excessive Zeros and Low Average Density

These are counts of the number of times the DSU transmits toward the network a signal with a corrected pulse density in accordance with the selection for the Ones Density option. Only one displays the count. Excessive Zeros is a count of the number of times the equipment is in a zeros violation. The threshold for this counter is dependent on the selection of the Ones Density option (maximum of 15 or 39 zeros), defining the maximum number of consecutive zeros transmitted before a "one" is inserted. Low Average Density is a count of the number of times the DSU transmits a signal with an average pulse density less than that selected with the Ones Density option (minimum of N "ones" per $8(N+1)$ bits, where $N = 1$ to 24).

OTHER ALARMS

Bipolar Violations

A bipolar violation (BPV) event occurs when the DSU receives from the network two or more consecutive bits that do not alternate between signal polarities as required by the network for Alternate Mark Inversion (AMI) line coding. The status line network BPV and front panel NETWORK BPV and NETWORK ERR indicators reflect the current status of BPV error events.

CRC Errors

A CRC error event occurs when the CRC-6 code calculated at the receiving end does not match the CRC-6 code calculated by the transmitting end. The CRC is a method of detecting errors in the DS1 signal, and is performed on each ESF superframe. The status line network CRC and front panel NETWORK ERR indicators reflect the current status of CRC error events.

Controlled Slips

A controlled slip event is the occurrence of a replication or deletion of one DS1 frame by the receiving equipment. A controlled slip event occurs when the difference in the timing between the synchronous receiving equipment and the received signal is of such magnitude that it exhausts the buffer capability of the equipment.

Initialize Alarm History

This function clears from memory (initializes) the count for each of the above errors. The alarm counters should be initialized daily, because once they reach their maximum value they no longer provide accurate information. To use this function, press I. The DSU prompts Are You Sure? (Y/N). Press N to abort this function, or Y to continue.

OPERATION

Twenty-Four Hour Reports Menu

The Twenty-Four Hour Reports menu, illustrated in Figure 3-12, accesses the following reports:

- Local User Twenty-Four Hour Report — displays the user register set for the local DSU (i.e., the DSU to which the Supervisory terminal is connected).
- Remote User Twenty-Four Hour Report — displays the user register set for the remote DSU (i.e., the DSU on the other end of the communications line).
- Remote Network Twenty-Four Hour Report — displays the network register set for the remote DSU.

Each of these reports is discussed separately below. To access the Twenty-Four Hour Reports menu, press T.

```
network STATUS          network - DIAG - channel
OOF NS YEL AIS NLB BPV CRC      LT ST RT  RDL ST DL LL  CFG HARD
. . . . .

L Local User Report
U Remote User Report
N Remote Network Report
E Exit

Privilege: FULL CONTROL

Select option:
```

FIGURE 3-12. TWENTY-FOUR HOUR REPORTS MENU

**LOCAL USER
TWENTY-FOUR
HOUR REPORT
SCREEN**

The Local User Twenty-Four Hour Report screen displays the user register set for the local DSU (i.e., the DSU to which the Supervisory terminal is connected). It spans three pages vertically, each displaying eight one-hour intervals. (Press N to move to the next page, or P for the previous page.) It spans three pages horizontally, each displaying one or two groups of error counts: ES and UAS are displayed on one page; BES and SES are displayed on the next page; and LOFC is displayed on the next. (Press the spacebar to move to the next page). When you access this screen later, you begin with the page that was last displayed. Figure 3-13 illustrates how to move between pages of the new Local User Twenty-Four Hour Report screen, and Figure 3-14 illustrates typical pages of this screen.

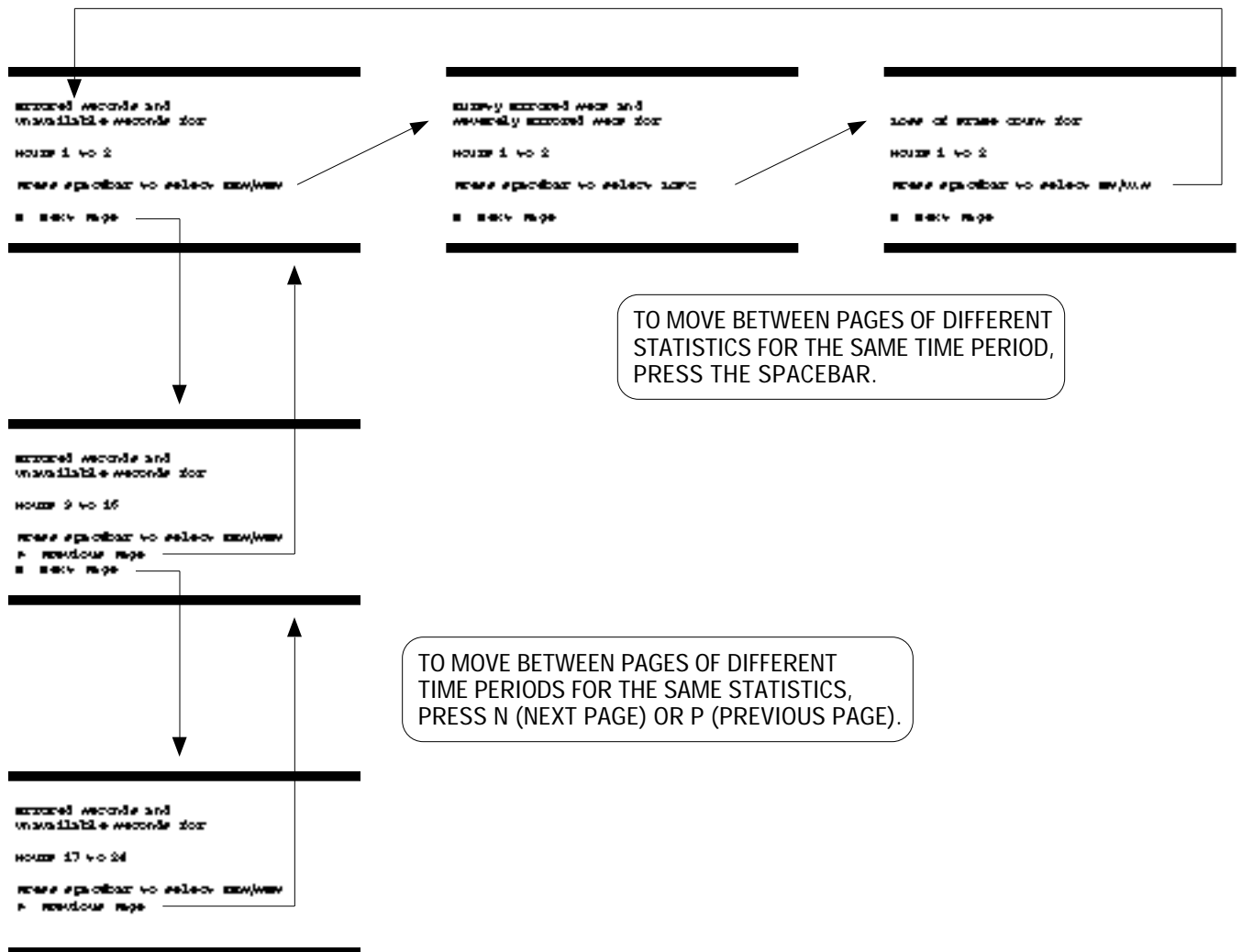

FIGURE 3-13. LOCAL USER TWENTY-FOUR HOUR REPORT SCREEN PAGES

OPERATION

Last 24 Hours: ES UAS BES SES LOFC

These are the total counts for ES, UAS, BES, SES and LOFC for the past 24 hours of operation, including counts for the current interval. The maximum displayed count is 65535 for each except LOFC, which is 255. If the actual count exceeds this number, the counter freezes until reset with the Initialize Counters function or until the error condition is cleared.

Interval Hour Start End Date

This is a list of the 24 most recent **one-hour intervals**, each beginning and ending on the hour (starting with the first full hour). It spans three eight-hour screens (pages). The first page is for hours 1 (always the current interval) through 8, the second is for hours 9 through 16, and the third page is for hours 17 through 24. If no data exists beyond a given hour, Unavailable is displayed instead of the Start, End and Date entries. The current 15-minute interval is highlighted.

(statistic) 1st 2nd 3rd 4th

The following applies to all of the error counters, or statistics, displayed (Errored Seconds, Unavailable Seconds, Bursty Errored Secs, Severely Errored Secs, and Loss of Frame Count):

These are counts for each of the four 15-minute intervals for each hour. The current interval is highlighted. Every 15 minutes, the next interval to the right is highlighted and displays new data. The maximum count is 900 (15 minutes = 900 seconds) for each except Loss of Frame Count, which is 90. If no data exists for a given interval, a * is displayed instead of a count. Every hour, the data from each line is shifted down into the next line and is replaced by the data from the line above it or by new data (in the first line only).

Initialize Counters

This function clears (resets to 0) the counters for the user register set, but it does not clear similar counters for the network register set maintained for reports to be transmitted to the network. To use this function, press I.

```

network STATUS          network - DIAG - channel
OOF NS YEL AIS NLB BPV CRC   LT ST RT  RDL ST DL LL  CFG HARD
. . . . .
      ES   UAS   BES   SES  LOFC
Last 24 Hours:  42  105  10  32  6

Interval      Errored Seconds      Unavailable Seconds
Hour Start  End  Date  1st 2nd 3rd 4th  1st 2nd 3rd 4th
1 08:00P 09:00P 31-DEC-92 14 0 0 0 0 0 0 0
2 07:00P 08:00P 31-DEC-92 -92 0 0 0 0 0 0 0
3 06:00P 07:00P 31-DEC-92 0 0 0 0 0 0 0 0
4 05:00P 06:00P 31-DEC-92 0 0 0 0 0 0 0 0
5 04:00P 05:00P 31-DEC-92 13 0 9 0 71 0 0 0
6 03:31P 04:00P 31-DEC-92 * * 5 1 * * 10 24
7 Unavailable * * * * * * * *
8 Unavailable * * * * * * * *

I Initialize Counters      * Indicates data unavailable
                          Press spacebar to select BES/SES
N Next Page
E Exit                    Privilege: FULL CONTROL
  
```

Select option:

EVERY HOUR, DATA FROM FROM EACH LINE IS SHIFTED DOWN INTO THE NEXT LINE.

A. ES/UAS ERROR COUNTS

```

network STATUS          network - DIAG - channel
OOF NS YEL AIS NLB BPV CRC   LT ST RT  RDL ST DL LL  CFG HARD
. . . . .
      ES   UAS   BES   SES  LOFC
Last 24 Hours:  42  105  10  32  6

Interval      Bursty Errored Secs  Severely Errored Secs
Hour Start  End  Date  1st 2nd 3rd 4th  1st 2nd 3rd 4th
1 08:00P 09:00P 31-DEC-92 1 0 0 0 13 0
2 07:00P 08:00P 31-DEC-92 0 0 0 0 0 0 0 0
3 06:00P 07:00P 31-DEC-92 0 0 0 0 0 0 0 0
4 05:00P 06:00P 31-DEC-92 0 0 0 0 0 0 0 0
5 04:00P 05:00P 31-DEC-92 5 0 1 0 8 0 8 0
6 03:31P 04:00P 31-DEC-92 * * 2 1 * * 3 0
7 Unavailable * * * * * * * *
8 Unavailable * * * * * * * *

I Initialize Counters      * Indicates data unavailable
                          Press spacebar to select LOFC
N Next Page
E Exit                    Privilege: FULL CONTROL
  
```

Select option:

B. BES/SES ERROR COUNTS

FIGURE 3-14. LOCAL USER TWENTY-FOUR HOUR REPORT SCREEN (Sheet 1 of 2)

OPERATION

```
network STATUS          network - DIAG - channel
OOF NS YEL AIS NLB BPV CRC      LT ST RT  RDL ST DL LL  CFG HARD
. . . . .
      ES   UAS   BES   SES  LOFC
Last 24 Hours: 42  105  10  32  6

Interval      Loss of Frame Count
Hour Start  End   Date   1st 2nd 3rd 4th
1 08:00P 09:00P 31-DEC-92  1  0
2 07:00P 08:00P   31-DEC-92  0  0  0  0
3 06:00P 07:00P   31-DEC-92  0  0  0  0
4 05:00P 06:00P   31-DEC-92  0  0  0  0
5 04:00P 05:00P 31-DEC-92  2  0  1  0
6 03:31P 04:00P   31-DEC-92  *  *  1  1
7 Unavailable * * * *
8 Unavailable * * * *

I Initialize Counters      * Indicates data unavailable
                             Press spacebar to select ES/UAS
N Next Page
E Exit                     Privilege: FULL CONTROL

Select option:
```

C. LOFC ERROR COUNTS

FIGURE 3-14. LOCAL USER TWENTY-FOUR HOUR REPORT SCREEN (Sheet 2 of 2)

REMOTE USER
TWENTY-FOUR
HOUR REPORT
SCREEN

The Remote User Twenty-Four Hour Report screen displays the user register set for the remote DSU (i.e., the DSU on the other end of the communications line). It is five screens (pages) wide, one for each error, or statistic: ES, UAS, BES, SES and LOFC. It displays up to ninety-six 15-minute intervals (24 hours) for each statistic. (Press N to move to the next statistic.) When you access this screen later, you begin with the page that was last displayed. Figure 3-15 illustrates the screen for ES. The screens for the others follow the same format.

NOTE

If the remote DSU does not support the enhanced parameter set defined in PUB 54016, or if the local DSU does not receive a response from the remote DSU within the expected time, or if a communications errors occurs, the message FDL Communications Error is displayed at the bottom of the screen.

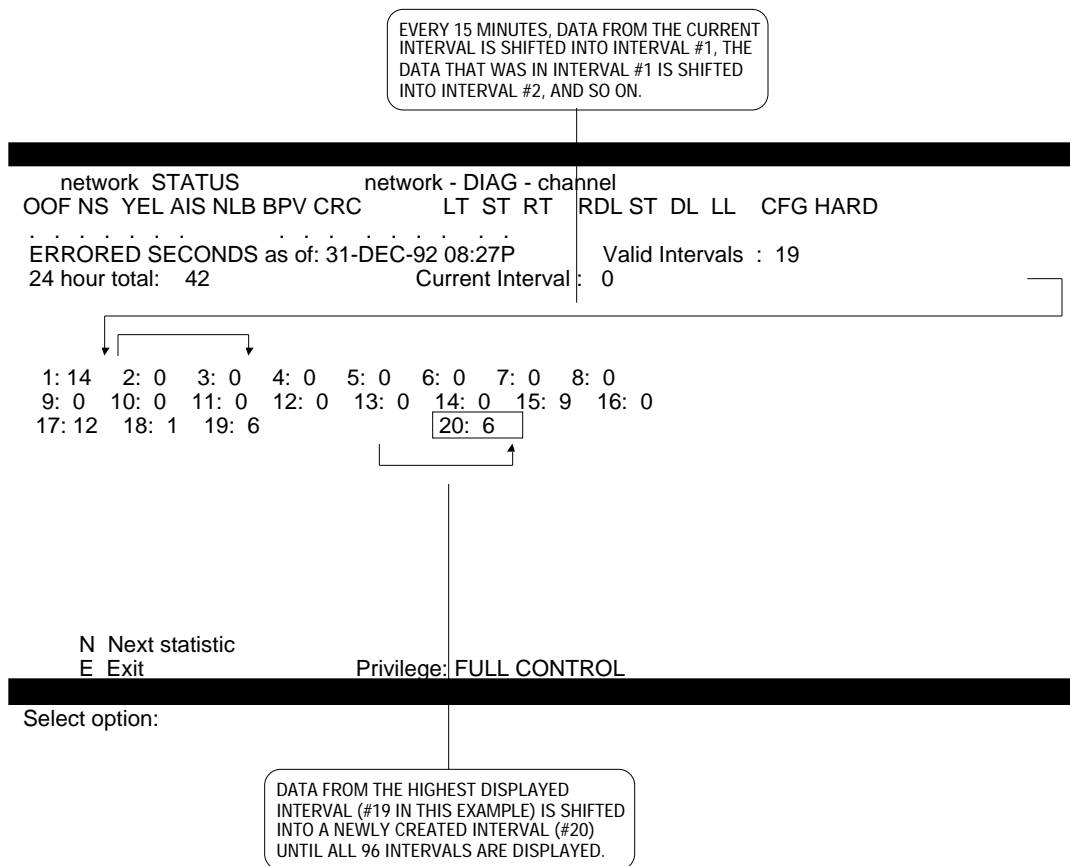

FIGURE 3-15. REMOTE USER TWENTY-FOUR HOUR REPORT SCREEN (ERRORED SECONDS)

OPERATION

(statistic) as of: (date and time)

This is the statistic being displayed (ERRORED SECONDS, UNAVAILABLE SECONDS, BURSTY ERRORED SECONDS, SEVERELY ERRORED SECONDS, or LOSS OF FRAME COUNT), and the date and time of the last update for the report, which occurs every 15 minutes after you access it. (When you access this report from the Twenty-Four Hour Reports menu, and every 15 minutes thereafter until you exit it, the local DSU requests the remote DSU to send its register set. On receiving the data, which may involve a delay, the local DSU updates the entire report.)

NOTE

To manually update the report, without waiting for the automatic 15-minute update, exit the report and access it again. This causes the local DSU to request the remote DSU to send its register set again.

Valid Intervals :

This is the number of valid 15-minute intervals since the last power up. (The current interval, and intervals for which no data exists, are not valid intervals.) This number equals the number of intervals displayed below, and ranges from 0 to 96.

24 hour total:

This is the total count for the past 24 hours of operation, including counts for the current interval. The maximum displayed count is 65535 for each except LOFC, which is 255. If the actual count exceeds this number, the counter freezes until reset with the Initialize Counters function on the Local User Twenty-Four Hour Report screen or until the error condition is cleared.

Current Interval :

This is the error count for the current 15-minute interval. The maximum displayed count is 900 for each except LOFC, which is 90.

(15-minute interval):

The middle of the screen displays the counts for the most recent valid 15-minute intervals, at eight intervals per line. Every 15 minutes, the data from one interval is shifted into the next interval (creating a new interval if required) and is replaced by the data from the previous interval.

REMOTE
NETWORK
TWENTY-FOUR
HOUR REPORT
SCREEN

The Remote Network Twenty-Four Hour Report screen displays the network register set for the remote DSU (i.e., the DSU on the other end of the communications line). It is five screens (pages) wide, one for each error, or statistic: ES, UAS, BES, SES and LOFC. It displays up to ninety-six 15-minute intervals (24 hours) for each statistic. (Press N to move to the next statistic.) When you access this screen later, you begin with the page that was last displayed. Figure 3-16 illustrates the screen for ES. The screens for the others follow the same format.

NOTE

If the remote DSU does not support the enhanced parameter set defined in PUB 54016, or if the local DSU does not receive a response from the remote DSU within the expected time, or if a communications errors occurs, the message FDL Communications Error is displayed at the bottom of the screen.

```

network STATUS          network - DIAG - channel
OOF NS YEL AIS NLB BPV CRC      LT ST RT  RDL ST DL LL  CFG HARD
.....
ERRORED SECONDS as of: 31-DEC-92 08:29P      Valid Intervals : 21
24 hour total: 62                Current Interval : 0

1: 0  2: 14  3: 0  4: 0  5: 0  6: 0  7: 0  8: 0
9: 0 10: 0 11: 0 12: 0 13: 0 14: 0 15: 9 16: 0
17: 11 18: 1 19: 7 20: 0 21: 20

N Next statistic
E Exit                Privilege: FULL CONTROL
Select option:

```

FIGURE 3-16. REMOTE NETWORK TWENTY-FOUR HOUR REPORT SCREEN (ERRORED SECONDS)

OPERATION

(statistic) as of: (date and time)

This is the statistic being displayed (ERRORED SECONDS, UNAVAILABLE SECONDS, BURSTY ERRORED SECONDS, SEVERELY ERRORED SECONDS, or LOSS OF FRAME COUNT), and the date and time of the last update for the report, which occurs every 15 minutes after you access it. (When you access this report from the Twenty-Four Hour Reports menu, and every 15 minutes thereafter until you exit it, the local DSU requests the remote DSU to send its register set. On receiving the data, which may involve a delay, the local DSU updates the entire report.)

NOTE

To manually update the report, without waiting for the automatic 15-minute update, exit the report and access it again. This causes the local DSU to request the remote DSU to send its register set again.

Valid Intervals :

This is the number of valid 15-minute intervals since the last power up. (The current interval, and intervals for which no data exists, are not valid intervals.) This number equals the number of intervals displayed below, and ranges from 0 to 96.

24 hour total:

This is the total count for the past 24 hours, NOT including counts for the current interval, since the last power up. The maximum displayed count is 65535 for each except LOFC, which is 255. If the actual count exceeds this number, the counter freezes until reset with the Initialize Counters function on the Local User Twenty-Four Hour Report screen or until the error condition is cleared.

Current Interval :

This is the error count for the current 15-minute interval. The maximum displayed count is 900 for each except LOFC, which is 90.

(15-minute interval):

The middle of the screen displays the counts for the most recent valid 15-minute intervals, at eight intervals per line. Every 15 minutes, the data from one interval is shifted into the next interval (creating a new interval if required) and is replaced by the data from the previous interval.

SCHEDULED
PERFORMANCE
REPORT SCREEN

This function displays the information that the DSU makes available to the network upon its request for a Scheduled Performance Report. This information is available only for the ANSI mode. The information is displayed for the last four one-second periods and is updated once every second. The data in the 1st Sec column shifts to the right into the 2nd Sec column, and so on. A period (.) indicates that no error event occurred (a null event). To use this function, press C. Figure 3-17 illustrates the Scheduled Performance Report screen.

CRC Error Event

This is a count of CRC-6 error events, displayed in ranges, as follows:

- 0 no errors
- 1 1 error
- <5 from 2 to 4 errors
- <10 from 5 to 9 errors
- <100 from 10 to 99 errors
- <320 from 100 to 319 errors
- >320 320 or more errors

Severe Error Event

An asterisk (*) indicates that during this one-second interval one or more severely errored framing events occurred.

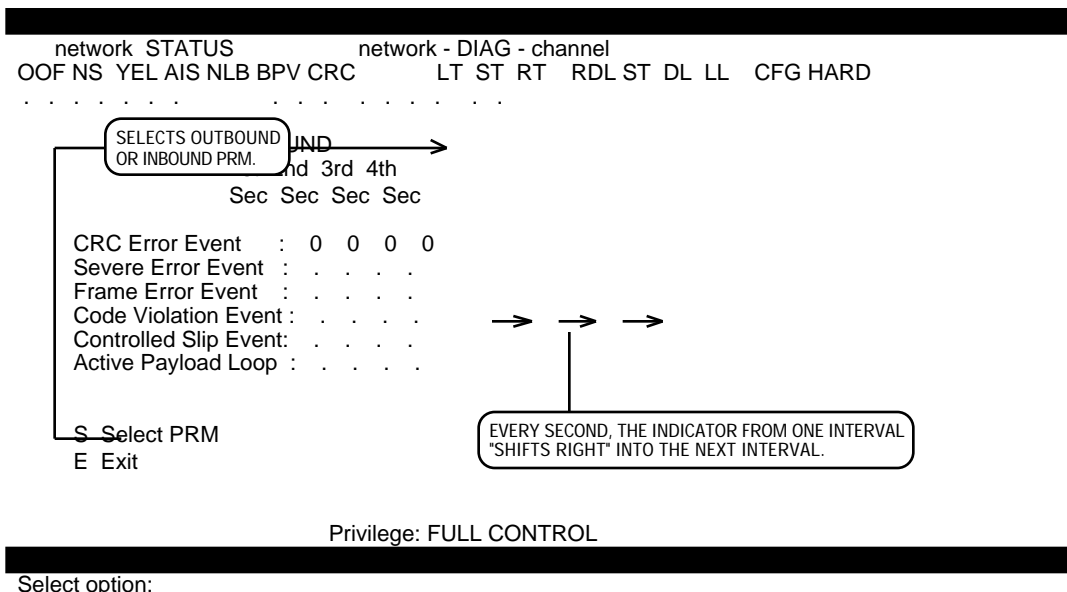

FIGURE 3-17. SCHEDULED PERFORMANCE REPORT SCREEN

OPERATION

Frame Error Event

An asterisk (*) indicates that during this one-second interval one or more frame synchronization bit error events occurred. A frame synchronization bit error event is not indicated (.) when a severely errored framing event also occurs.

Code Violation Event

An asterisk (*) indicates that during this one-second interval one or more line code violation events occurred.

Controlled Slip Event

An asterisk (*) indicates that during this one-second interval one or more controlled slip events occurred.

Active Payload Loop

An asterisk (*) indicates that during this one-second interval the DSU was in a payload loopback condition (looping back toward the network frames consisting of the received 192 information bits [the payload] plus its own framing, CRC-6, and Data Link bits [the F-bits]). A period (.) indicates that the DSU was not in a payload loopback condition.

Select PRM

This function causes the display to toggle between the Performance Report Message (PRM) transmitted toward the network (OUTBOUND) and received from the network (INBOUND). To use this function, press S.

**CSU SELF TEST
SCREEN**

This function causes the DSU to generate and verify a test pattern. The status line network ST and front panel TM indicators reflect the status of this test. To use this function, press S. Figure 3-18 illustrates the CSU Self Test screen. DS1 Self-Test can also be used with DS1 Local Test and DS1 Remote Test from the LOOPBACKS screen. Refer to DS1 Remote Test with Self-Test and DS1 Local Test with Self-Test in Section 4 for test procedures.

Test Pattern

This displays one of the following test patterns selected with the Select Test Pattern (S) function:

- 511 511-bit test pattern
- 2047 2047-bit test pattern
- PROG user-programmable test pattern
- QRS Quasi-Random Signal (QRS) test pattern

User Pattern

This displays the test pattern selected with the Set User Pattern (P) function. The default user-programmable pattern is 1100000000000000. However, Default is displayed instead of the actual default pattern.

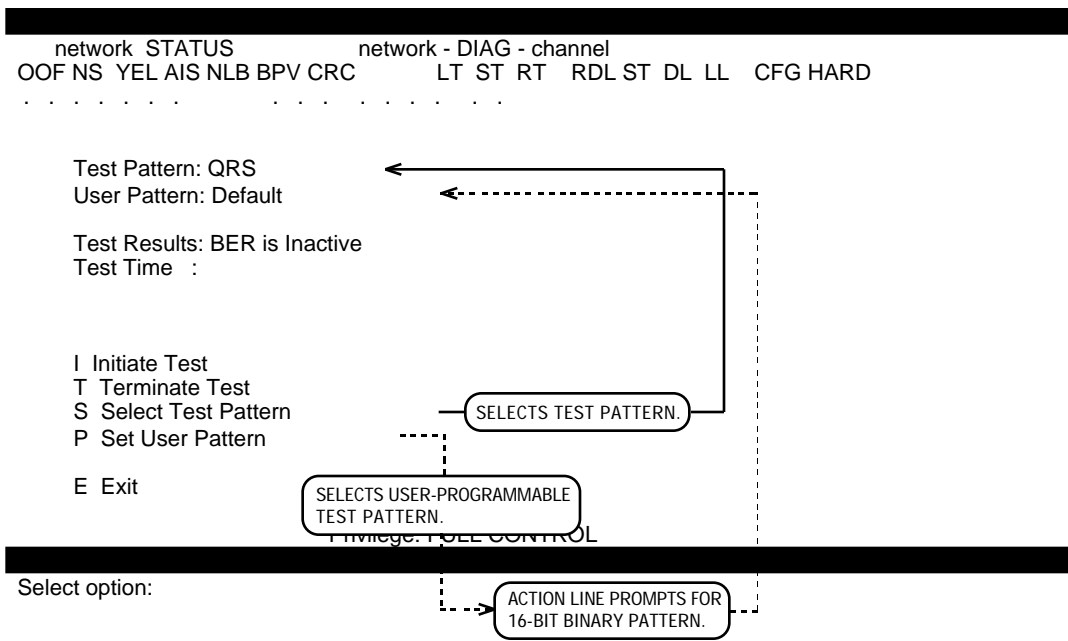

FIGURE 3-18. CSU SELF TEST SCREEN

OPERATION

Test Results

This displays the averaged BER, updated once every second. The maximum BER is 5.59E-3 (5.59×10^{-3} , or 5.59 bit errors per 1,000 bits). The minimum BER is 1.00E-7 (1.00×10^{-7} , or 1 bit error per 10,000,000 bits). While no test is running, BER is Inactive is displayed.

Test Time

This displays the duration (in seconds) of the current test. While no test is running, this is blank. During the first seven seconds after the test is started, the DSU is collecting and averaging initial results and displays Please Wait....

Initiate Test

This function starts the test. You cannot make any changes while the test is running, nor can you exit this screen. To use this function, press I.

NOTE

If you initiate a DS1 diagnostic while a DS0 diagnostic is in progress, the DS0 diagnostic is terminated.

Terminate Test

This function stops the test. To use this function, press T.

Select Test Pattern

This function selects the test pattern. To step through the test patterns (displayed in Test Pattern), press S.

NOTE

The QRS test pattern is typically used instead of the 511- or 2047-bit test patterns.

Set User Pattern

This function allows you to select your own test pattern. It is a 16-bit, binary pattern (ones and zeros). To use this function, press P. Enter 16 bits, and then press RETURN. The pattern is displayed in User Pattern. This pattern is retained when you exit this screen, but lost if the DSU is powered down.

LOOPBACK SCREEN

This function allows you to control one of five standard loopback tests: Test Loop, Line Loop, Local Test, Remote Test, and NI Loop. Once started, these tests must be stopped via the Supervisory terminal: they cannot be stopped via the front panel. To use this function, press L. Figure 3-19 illustrates the Loopbacks screen.

Loop Status

This displays the test that is running: Test Loop, Line Loop, Local Test, Remote Loop, or NI Loop. When no test is running, this displays NONE.

NOTE

If you initiate a DS1 diagnostic while a DS0 diagnostic is in progress, the DS0 diagnostic is terminated.

Test Loop

This function controls the DS1 Test Loop described in Section 4. The status line network NLB and front panel NETWORK LB indicators reflect the status of this test. To start or stop this test, press T.

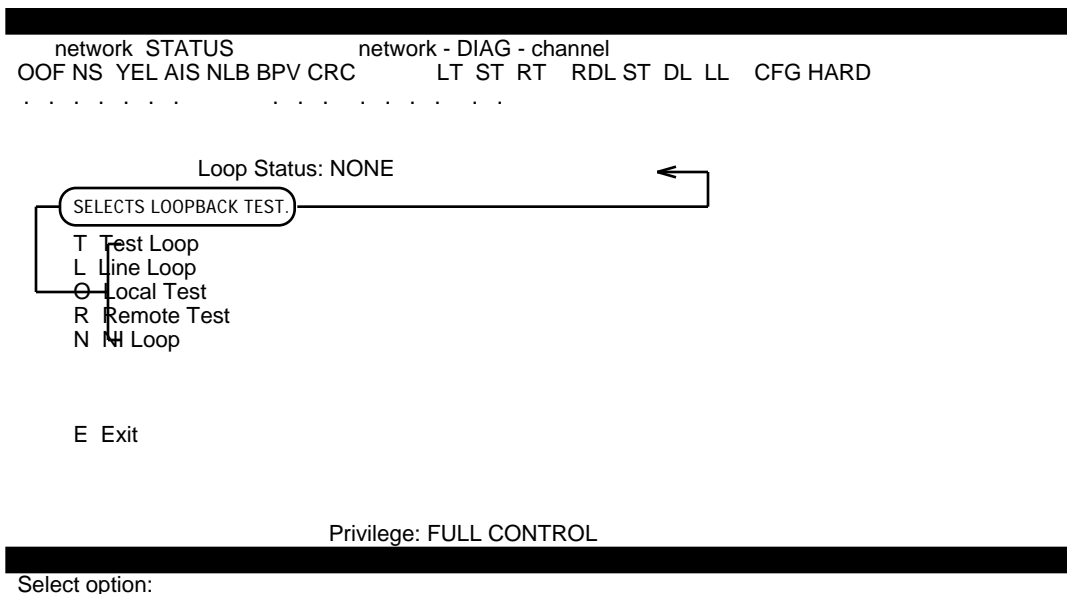

FIGURE 3-19. LOOPBACKS SCREEN

OPERATION

Line Loop

This function controls the DS1 Line Loop described in Section 4. The status line network NLB and front panel NETWORK LB indicators reflect the status of this test. To start or stop this test, press L.

Local Test

This function controls the DS1 Local Test described in Section 4. The status line network LT and front panel TM indicators reflect the status of this test. This test can also be used in conjunction with DS1 Self-Test to control the DS1 Local Test with Self-Test described in Section 4. To start or stop this test, press O.

Remote Test

This function controls the DS1 Remote Test described in Section 4. There is a five second delay after you start or stop this test. During these five-second intervals before and after the actual test, the DSU is required to send in-band loopback codes to the remote DSU. This test can also be used in conjunction with DS1 Self-Test to control the DS1 Remote Test with Self-Test described in Section 4. The status line network RT and front panel TM indicators reflect the status of this test. To start or stop this test, press R.

NI Loop

This function controls the DS1 Network Interface Loopback function described in Section 4. A Telco-provided DS1 Interface Connector (or Smart Jack) must be installed at the remote DSU. There is a five second delay after you start or stop this test. During these five-second intervals before and after the actual test, the DSU is required to send in-band loopback codes to the remote DSU. This test can also be used in conjunction with DS1 Self-Test to control the DS1 Network Interface Loopback with Self-Test described in Section 4. The status line network RT and front panel TM indicators reflect the status of this test. To start or stop this test, press N.

NOTE

When connected to a DS1 Interface Connector (or Smart Jack), the DSU must be configured for manual Network Line Build-Out (consult the carrier for the proper attenuation level).

RECEIVE LEVEL
SCREEN

This function displays information about the Network Line Build-Out option and the network signal. To use this function, press R. Figure 3-20 illustrates the Receive Level screen.

Line Build-out

This displays the amount of line build-out selected: 0.0 dB, 7.5 dB, or 15.0 dB. The Network Line Build-Out Amount is selected manually with the LINE BUILD-OUT (L) Configuration command or option switches S6-5 and S6-6, or automatically when automatic Network Line Build-Out is enabled with the LINE BUILD-OUT command or option switch S6-4.

NOTE

When connected to a DS1 Interface Connector (or Smart Jack), the DSU must be configured for manual Network Line Build-Out (consult the carrier for the proper attenuation level).

Receive Level

This displays the actual signal level received from the network. If the displayed signal level and manually-set Network Line Build-Out Amount do not agree, adjust the option setting to match the displayed signal level (refer to Table 2-1). The ranges displayed and appropriate option settings are:

Display	Nominal Cable Loss *	LBO Option Setting
0 to -7	0 dB to 7.5 dB (± 2.5 dB)	15 dB
-7 to -15	7.5 (± 2.5 dB) dB to 15 dB (± 2.5 dB)	7.5 dB
< -15	15 dB (± 2.5 dB) to 30 dB (± 2.5 dB)	0 dB
NO SIGNAL	greater than 30 dB (± 2.5 dB)	0 dB

* The variation in cable loss is pattern dependent.

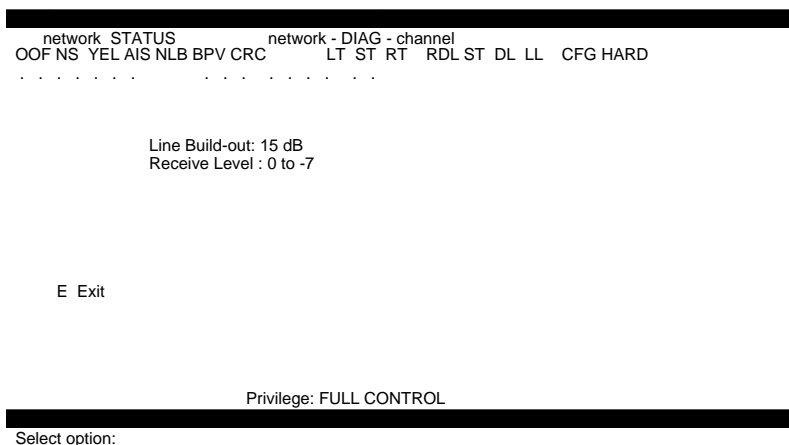

FIGURE 3-20. RECEIVE LEVEL SCREEN

OPERATION

The CSU Configuration Screen

The Supervisory terminal can be used to display and configure nearly all of the options that can be selected via option switches on the CSU-function card. Figure 3-21 illustrates the functions available through the CSU CONFIGURATION screen. (Refer also to The Channel Configuration Screen for channel configuration options.) Configuration selections made via the Supervisory terminal override those made via option switches. For a complete cross-reference of the DSU's hard- and soft-configurable options, refer to Appendix C.

Excluded from Supervisory terminal configuration are:

- DSU Address Number (option switches S5-1 through S5-8)
- Ground (option jumper X1)
- Front Panel Switches (option switch S4-7)
- Configuration Mode (option switch S6-7)
- PMC-100 Operation (option switch S4-3)
- Power to Span (option jumper X5)
- Soft Configuration Privileges (option switch S4-6)
- Supervisory Port Baud Rate (option switches S4-1 and S4-2)
- Supervisory Port Character Format (option switches S4-4 and S4-5)

```
network STATUS          network - DIAG - channel
OOF NS YEL AIS NLB BPV CRC      LT ST RT  RDL ST DL LL  CFG HARD
. . . . .

M ESF Mode   : ANSI
C Network Code : AMI
N Network Frame : MAN - ESF
O Ones Density : MAX 15 ZEROS
I Inband Loop  : ENABLE
T Test Type   : LLB
B ILB Frame    : FRAMED
A AIS Loopdown : INHIBIT
L Line Build-Out: MAN - 0.0 dB

E Exit

Privilege: FULL CONTROL

Select option:
```

FIGURE 3-21. CSU CONFIGURATION SCREEN

NOTE

In Hard Configuration Mode (set via option switch S6-7), configuration via the Supervisory terminal is not allowed.

To set an option, press the letter shown to the left of it. Each time you press the letter, you see a different choice. Stop when you see the desired choice. The information is updated when you begin this function and when you press RETURN while this screen is displayed. When you are done with configuration, press E to exit this function. The following paragraphs describe each of the configuration functions.

ESF Mode

This sets the Network Compatibility option to ANSI (complies with the requirements specified in Bellcore TR-TSY-000194 and adopted by ANSI — the American National Standards Institute) or AT+T (complies with the requirements specified in PUB 54016). These publications define, in part, the manner in which signal quality or performance measurements are determined, transmitted, and responded to. The ANSI mode supports Bellcore Scheduled Performance Report Messages (PRMs) and Unscheduled Messages, messages initiated by the Telco and contained in the Data Link subchannel provided in ESF framing. The PUB 54016 mode supports their Telemetry Asynchronous Block Serial Protocol (TABS), a maintenance message protocol initiated by the Telco and contained in the Data Link subchannel provided in ESF framing. This option applies only when ESF is selected for the Network Frame Format option. The default setting is ANSI. (This option is also set via option switch S6-8.)

Network Code

This sets the Line Code option for the network side to AMI (Alternate Mark Inversion, with no bipolar violations) or B8ZS (Bipolar with 8 Zero Substitution, with bipolar violations). Which one you choose depends primarily on the design of the T1 link: all equipment must be compatible with AMI coding, and some equipment may not be compatible with B8ZS coding. To implement 64 kbps Clear Channel Capability, you must choose B8ZS (the DSU automatically sets the Ones Density option to INHIBIT). The default setting is AMI. (This option is also set via option switch S3-5.)

Network Frame

This sets the Network Frame Format option for the network side to AUTO (Auto Framing) or MAN (manually-set framing), and one of the following framing types: ESF (Extended Superframe Format) or D4 (D4 Superframe Format). The default setting is MAN - ESF. (This option is also set via option switches S3-1 and S3-3.)

CAUTION

Do not enable Auto Framing for both DSUs on a link.

Ones Density

This sets the pulse density to MAX 15 ZEROS (maximum of 15 consecutive zeros transmitted toward the network before a "one" is inserted), MAX 39 ZEROS (maximum of 39 consecutive zeros), 8(N+1) RESTRICTIONS (minimum of N "ones" per 8(N+1) bits, where N = 1 to 24; the Line Code option for the network side must be set to AMI), MIN 1 IN 8 (minimum of 1 "one" per 8 bits; with this selection, pulse density violations are enforced but enforcement is not indicated to the user), or INHIBIT (no minimum pulse density is maintained). The default setting is MAX 15 ZEROS. (This option is also set via option switch S3-8.)

Inband Loop

This sets the In-Band DS1 Loopback Code Detection option to ENABLE (in-band loopback codes are detected and reacted to) or INHIBIT (in-band loopback codes are ignored). When ENABLE is selected, Test Type must also be set. When a loopback activation or deactivation code is detected, the DSU starts or stops the type of loopback test selected with Test Type. The default setting is ENABLE. (This option is also set via option switch S4-8.)

Test Type

This sets the In-Band DS1 Loopback Code Test Type option to LLB (DS1 Line Loop is started or stopped when the appropriate in-band loopback code is detected) or TLB (DS1 Test Loop is started or stopped), when Inband Loop is set to ENABLE. The default setting is LLB. (This option is also set via option switch S3-6.)

ILB Frame

This sets the In-Band DS1 Loopback Code Framing option to FRAMED (DSU transmits framed in-band loopback codes) or UNFRAMED (DSU transmits unframed in-band loopback codes), when a DS1 Remote Test is started. The default setting is FRAMED. (This option is also set via option switch S3-7.)

AIS Loopdown

This sets the AIS Loop-Down option for remotely-initiated DS1 loopbacks (i.e., those controlled by in-band codes) to INHIBIT (a continuous received AIS does not terminate the loopback), or ENABLE (a continuous received AIS terminates the loopback; recommended for any DSU cascaded to another DSU) with a loop-down activation time of 5 to 60 seconds. The loop-down activation time is the length of time of a continuous received AIS required before the DSU will terminate the loopback. An intermittent AIS is ignored. The default setting is INHIBIT. To select a loop-down activation time other than 30 seconds, press A, then enter the desired time in seconds.

Line Build-Out

This sets the Network Line Build-Out Amount option for line build-out on the network side to AUTO (automatic Network Line Build-Out, based on

the signal level received from the network) or MAN (manually-set Network Line Build-Out), and one of the following attenuation levels: 0.0 dB (no attenuation), 7.5 dB (7.5 dB attenuation), or 15 dB (15 dB attenuation). Selecting the proper signal level ensures that the signal reaching the Central Office is satisfactory. The default setting is MAN - 0.0 dB. (This option is also set via option switches S6-4, S6-5, and S6-6.)

CAUTION

- a. *When connected to a DS1 Interface Connector (or Smart Jack), the DSU must be configured for manual Network Line Build-Out (consult the carrier for the proper attenuation level).*
- b. *Do not enable automatic Network Line Build-Out for both DSUs when they are connected back-to-back.*

OPERATION

The Channel Configuration Screen

The Supervisory terminal can be used to display and configure nearly all of the options that can be selected via option switches on the DSU-function card. Figure 3-22 illustrates the functions available through the CHANNEL CONFIGURATION screen. (Refer also to The CSU Configuration Screen for other configuration options.) Configuration selections made via the Supervisory terminal override those made via option switches. For a complete cross-reference of the DSU's hard- and soft-configurable options, refer to Appendix C.

Excluded from Supervisory terminal configuration are:

- Remote Digital Loop Enable (option switch S12-2)
- Test Mode Status (option switch S12-3)
- Digital Loop Enable (option switch S12-4)
- Local Loop Enable (option switch S12-5)
- DSR Operation (option switch S12-6)
- Timing Options (option switches S14A-1, S14A-2, and S14A-5)

```
network STATUS          network - DIAG - channel
OOF NS YEL AIS NLB BPV CRC      LT ST RT  RDL ST DL LL  CFG HARD
. . . . .                  . . . . .

DS0: 1 2 3 4 5 6 7 8 9 10 11 12 13 14 15 16 17 18 19 20 21 22 23 24
X : X X X X X X X X X X X X X X . . . . .

Channel Data Rate: 832 KBPS

S Starting DS0 Number: 1
O RTS-to-CTS Option : CTS DELAYED
M Control Mode Idle : OFF
I RDL Inband Code  : FIXED
R Enter Channel Rate

A Alternate DS0    : OFF
L Respond to RDL  : YES
T Inband DL Timeout : INHIBIT

E Exit              Privilege: FULL CONTROL

Select option:
```

FIGURE 3-22. CHANNEL CONFIGURATION SCREEN

NOTE

- a. *In Hard Configuration Mode (set via option switch S6-7), configuration via the Supervisory terminal is not allowed.*
- b. *This screen does not reflect option switch settings, although the status line CFG indicator displays an X if there is an unsuitable option switch configuration while in Hard Configuration Mode.*

DS0 and X

These display the DS0s used (1 to 24) for the channel. A period (.) indicates that the DS0 is not used for channel data. Which DS0s the channel uses depends on its data rate and where its bandwidth begins. In the sample configuration shown in Figure 3-22, the channel has a data rate of 832 kbps and uses 13 DS0s (DS0s 1 through 13). DS0s 14 through 24 are not used for channel data.

Channel Data Rate

This displays the data rate (0 KBPS to 1536 KBPS) selected for the channel via the Supervisory terminal.

Starting DS0 Number

This sets the Starting DS0 Number option for the channel to 1 to 24, defining where the channel's bandwidth begins. The number of DS0s used (the DS0 bundle) depends on the customer equipment's data rate and whether the network accommodates Nx56 kbps DS0s or Nx64 kbps "Clear Channel" DS0s, and is calculated automatically by the DSU after you enter the starting DS0. The default setting is 1 (one). To set this option, press S and then enter the starting DS0. (This option is also set via option switches S15-7 through S16-3.)

Table 3-3 shows the relationship between bandwidth and the number of DS0s required. Use it to determine how many DS0s a given bandwidth requires, instead of performing calculations. To find out the highest starting DS0, subtract the required number of DS0s from 25. A 168 kbps bandwidth using Nx56 kbps DS0s, for example, requires 3 consecutive DS0s (1/8 of the full T1 bandwidth), and the highest DS0 at which it can start is 22 (25 - 3). Table 3-3 also shows the remaining bandwidth and number of DS0s, assuming the channel starts at DS0 number 1. Simply read across the table from the bandwidth already allocated to find how much is available.

TABLE 3-3. CHANNEL STARTING DS0 AND DATA RATE SELECTION

Rate Nx56/Nx64	Consecutive DS0s Allocated *	Consecutive DS0s Available *	Rate Nx56/Nx64
0/0	0	<u>24</u>	1344/1536
56/64	1	23	1288/1472
112/128	2	22	1232/1408
168/192	3 (1/8)	<u>21 (7/8)</u>	1176/ <u>1344</u>
224/256	4	20	1120/1280
280/320	5	19	1064/1216
336/384	6 (1/4)	18 (3/4)	1008/1152
<u>392/448</u>	<u>7</u>	17	952/1088
<u>448/512</u>	<u>8</u>	<u>16</u>	<u>896/1024</u>
504/576	9 (3/8)	15 (5/8)	840/960
560/640	10	<u>14</u>	784/ <u>896</u>
616/704	11	13	728/832
672/768	12 (1/2)	12 (1/2)	672/768
728/832	13	11	616/704
<u>784/896</u>	<u>14</u>	10	560/640
840/960	15 (5/8)	9 (3/8)	504/576
<u>896/1024</u>	<u>16</u>	<u>8</u>	<u>448/512</u>
952/1088	17	<u>7</u>	392/ <u>448</u>
1008/1152	18 (3/4)	6 (1/4)	336/384
1064/1216	19	5	280/320
1120/1280	20	4	224/256
<u>1176/1344</u>	<u>21 (7/8)</u>	3 (1/8)	168/192
1232/1408	22	2	112/128
1288/1472	23	1	56/64
<u>1344/1536</u>	<u>24</u>	0	0/0
<p>* The figure in parenthesis is the fraction of the full T1 bandwidth utilized, expressed in eighths.</p> <p>The underlined figures indicate bandwidths that are multiples of both Nx56 kbps and Nx64 kbps (i.e., 448, 896, and 1344 kbps).</p>			

RTS-to-CTS Option

This sets the CTS Operation option for the channel to CTS DELAYED (CTS responds to RTS after a 10 ms delay) or CTS FORCED ON (CTS is forced ON at all times). The default setting is CTS DELAYED . To set this option, press O to toggle between choices. (This option is also set via option switch S12-8.)

When performing certain diagnostics and during certain error conditions, the DSU causes CTS (and other leads) to behave differently than

indicated above. It does so in order to signal the customer channel equipment not to send data, as these conditions may cause loss of data. Refer to Option Selection in Section 2 for additional information.

Control Mode Idle Option

This sets the CMI Signalling option for the channel to OFF (CMI signalling is disabled) or ON (CMI signalling is enabled for use in polling applications on 56 kbps DDS I lines with remote DSUs such as GDC's DataComm 500G/UXR). The default setting is OFF. To set this option, press M to toggle between choices. (This option is also set via option switch S12-7.)

NOTE

- a. *This option is available only when the DS0 Type option is Nx56 kbps.*
- b. *CMI is compatible only with FT1 lines using Nx56 kbps DS0s, and full-rate 56 kbps DDS I lines. Do not use it with a sub-rate or DDS II (Secondary Channel) line.*

RDL Inband Code

This sets the Remote Digital Loop Pattern option for the channel to PN-127 (scrambled loop-up/down in-band codes for RDL) or FIXED (fixed codes). The default setting is PN-127. To set this option, press I to toggle between choices. (This option is also set via option switch S12-1.)

The DSU uses either fixed or scrambled loopback codes. The fixed 7-bit binary loop-up code that puts the channel in loopback is "1100000" and the loop-down code that takes it out of loopback is "1110000," with a delay of five seconds. The scrambled code is generated by the polynomial $1 + x^3 + x^7$, similar to that used in PN-127, and the code is sent for two seconds. The codes must be the same for both DSUs.

Enter Channel Rate

This sets the Channel Data Rate option for the channel to 0 KBPS to 1536 KBPS, and is used by the DSU to calculate the number of DS0s, or bandwidth, required for the channel. The data rate depends on the customer equipment's data rate and must equal or exceed it. The available rates range from 0 kbps to 1536 kbps, in Nx56 kbps and Nx64 kbps multiples. An Nx56 kbps DS0 sets one-eighth of the bits in the DS0 to ones (bit 8 of each DS0 octet), maintaining ones density at 12.5%. An Nx64 kbps DS0 allows each bit in the DS0 to carry customer data. The default setting is 56 KBPS. To set this option, press R and then enter the data rate. If you enter a rate that is a multiple of both Nx56 kbps and Nx64 kbps (i.e., 448 kbps, 896 kbps, or 1344 kbps), you are prompted with Enter 64 or 56 KBS mode. Enter 64 or 56 (the DS0 Type) and the DSU then calculates the number of DS0s required for the channel. If you enter an invalid rate, Invalid Rate - Must be multiple of 64 or 56 KBPS is displayed at the bottom of the screen. (This option is also set via option switches S15-1 through S15-6.)

Display Current Configuration

This function is displayed only when certain channel configuration errors have been made via the Supervisory terminal and alerts you of potential problems or conflicts (the DSU will not store an invalid configuration). Either correct the error or use this function (press D) to restore the configuration to the last valid configuration. If you make a change that would result in bandwidth extending beyond DS0 24 (i.e., you enter a Starting DS0 Number that is too high or a Channel Rate that is too large, or enable Alternate DS0 when only consecutive DS0s is appropriate), CONFIGURATION ERROR is displayed at the bottom of the screen.

In the sample configuration shown in Figure 3-23A, the channel is configured for a data rate of 832 kbps, beginning at DS0 1 (it uses 13 DS0s, DS0s 1 through 13), with consecutive DS0s (Figure 3-23B). An attempt is made to configure it for alternate DS0s. This results in bandwidth extending beyond DS0 24 (to DS0 25, if it existed). The DSU will not accept this configuration and allows you to abandon it and display the current one (Figure 3-23A) by pressing D.

Alternate DS0

This sets the Alternate DS0 option to OFF (channel data is carried in consecutive blocks of DS0s, and the full T1 bandwidth is available for customer data) or ON (channel data is carried in alternate DS0s, with unused DS0s carrying all ones. Only one-half of the T1 bandwidth is available for customer data, and minimum ones density is maintained at 50%). The default setting is OFF. To set this option, press A to toggle between choices. (This option is also set via option switch S10-7.)

Respond to RDL

This sets the Channel RDL Response option to YES (the channel responds to in-band loopback codes for Digital Loop received from the network or the remote DSU) or NO (the channel ignores in-band loopback codes). The default setting is YES. To set this option, press L to toggle between choices. (This option is also set via option switch S10-8.)

Inband DL Timeout

This sets the Channel Digital Loop Timer option for remotely-initiated Channel Digital Loop tests to INHIBIT (the test is unaffected) or ENABLE (the test is terminated after 10 minutes). The default setting is INHIBIT . To set this option, press T to toggle between choices.

```

network STATUS          network - DIAG - channel
OOF NS YEL AIS NLB BPV CRC      LT ST RT  RDL ST DL LL  CFG HARD
. . . . .
DS0: 1 2 3 4 5 6 7 8 9 10 11 12 13 14 15 16 17 18 19 20 21 22 23 24
X : X X X X X X X X X X X X X X . . . . .

```

Channel Data Rate: 832 KBPS

```

S Starting DS0 Number: 1
O RTS-to-CTS Option : CTS DELAYED
M Control Mode Idle : OFF
I RDL Inband Code   : FIXED
R Enter Channel Rate

```

```

A Alternate DS0      : OFF
L Respond to RDL    : YES
T Inband DL Timeout : INHIBIT

```

```

E Exit                      Privilege: FULL CONTROL

```

Select option:

A. DISPLAY OF CURRENT CONFIGURATION

```

network STATUS          network - DIAG - channel
OOF NS YEL AIS NLB BPV CRC      LT ST RT  RDL ST DL LL  CFG HARD
. . . . .
DS0: 1 2 3 4 5 6 7 8 9 10 11 12 13 14 15 16 17 18 19 20 21 22 23 24
X : X . X . X . X . X . X . X . X . X . X . X . X .

```

Channel Data Rate: 832 KBPS

```

S Starting DS0 Number: 1
O RTS-to-CTS Option : CTS DELAYED
M Control Mode Idle : OFF
I RDL Inband Code   : FIXED
R Enter Channel Rate

```

```

A Alternate DS0      : ON
L Respond to RDL    : YES
T Inband DL Timeout : INHIBIT

```

```

D Display Current Configuration
E Exit                      Privilege: FULL CONTROL

```

Select option:

B. DISPLAY AFTER IMPROPER ENTRY

FIGURE 3-23. CHANNEL CONFIGURATION ERROR

OPERATION

The Maintenance Screen

The Supervisory terminal can be used to set the DSU date and time, and to select a new DSU address. Figure 3-24 illustrates the functions available through the Maintenance screen.

Set Date

This function sets the DSU date. The date is entered in the mm-dd-yy format, where mm is the month (January = 01, etc.), dd is the day of the month, and yy is the year (1989 = 89). Separate each with a character such as a hyphen, comma, period, diagonal, or space. It will be converted and displayed as a hyphen. To set the date, press D.

Set Time

This function sets the DSU time of day. The time is entered in the hh:mm:ss format, where hh is the hour, mm is the minutes, and ss is the seconds. Include A for AM, or P for PM. Separate each with a character such as a hyphen, comma, period, diagonal, or space. It will be converted and displayed as a colon. To set the time, press T.

Set Factory Defaults

This function sets all soft-configurable options to the default factory settings. To set the options to their defaults, press F.

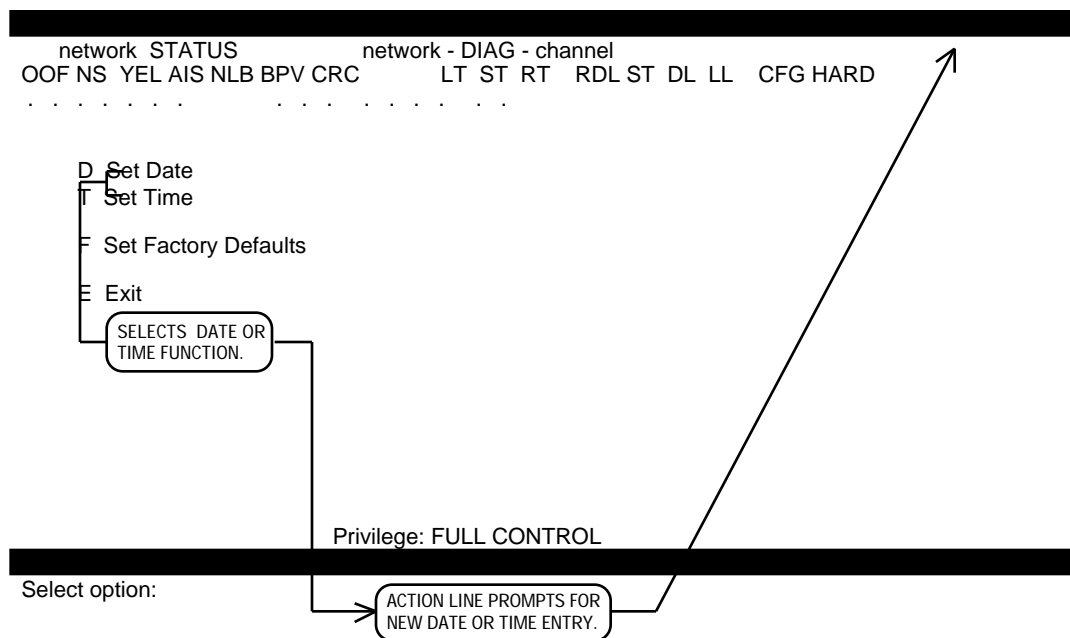

FIGURE 3-24. MAINTENANCE SCREEN

SECTION 4

TESTS

OVERVIEW

This section describes the tests that can be performed with the DataComm 552A-1 V1.1 after installation, whenever the operation of it must be checked, or when problems in the data communications system must be isolated (see Figure 4-1). Some tests prevent normal operation of the DSU and should be performed only when the DSU is not in use, while others have no impact on operation and can be performed anytime. Some tests utilize a minimum of the DSU's circuitry, while others utilize a maximum. Knowing this helps in analyzing the results of a series of tests to determine the probable source of errors. Each test is described in detail in the following pages. The tests are grouped and presented as follows:

DS1 Loopback Functions

- DS1 Line Loopback Function
- DS1 Network Interface Loopback Function
- DS1 Test Loopback Function

DS1 Diagnostics

- DS1 Line Loop
- DS1 Line Loop with Self-Test
- DS1 Local Test
- DS1 Local Test with Self-Test
- DS1 Network Interface Loopback
- DS1 Network Interface Loopback with Self-Test
- DS1 Remote Test
- DS1 Remote Test with Self-Test
- DS1 Self-Test (including DS1 End-to-End Self-Test)
- DS1 Test Loop
- DS1 Test Loop with Self-Test

TESTS

DS0 Diagnostics

- DS0 Circuit Delay Measurement Test
- DS0 Remote Test
- DS0 Remote Test with Self-Test
- DS0 Self-Test (including DS0 End-to-End Self-Test)

Channel Diagnostics

- Channel Digital Loop
- Channel Local Loop
- Channel Remote Digital Loop
- Channel Remote Digital Loop with Self-Test
- Channel Self-Test (including Channel End-to-End Self-Test)

The tests are controlled in one or more of the following ways: via the front panel switches, the Supervisory terminal, or loopback codes received from the network. Refer to Supervisory Terminal Operating Procedures in Section 3 for details on controlling the tests via the Supervisory terminal.

If technical assistance from GDC is required, refer to the Technical Assistance Procedure given at the end of this section.

NOTE

For self-tests, the QRS (Quasi-Random Signal) test pattern is typically used instead of the 511- or 2047-bit test patterns. To select the self-test pattern, refer to either the DS0 Diagnostics Screen or the CSU Self Test Screen in Section 3.

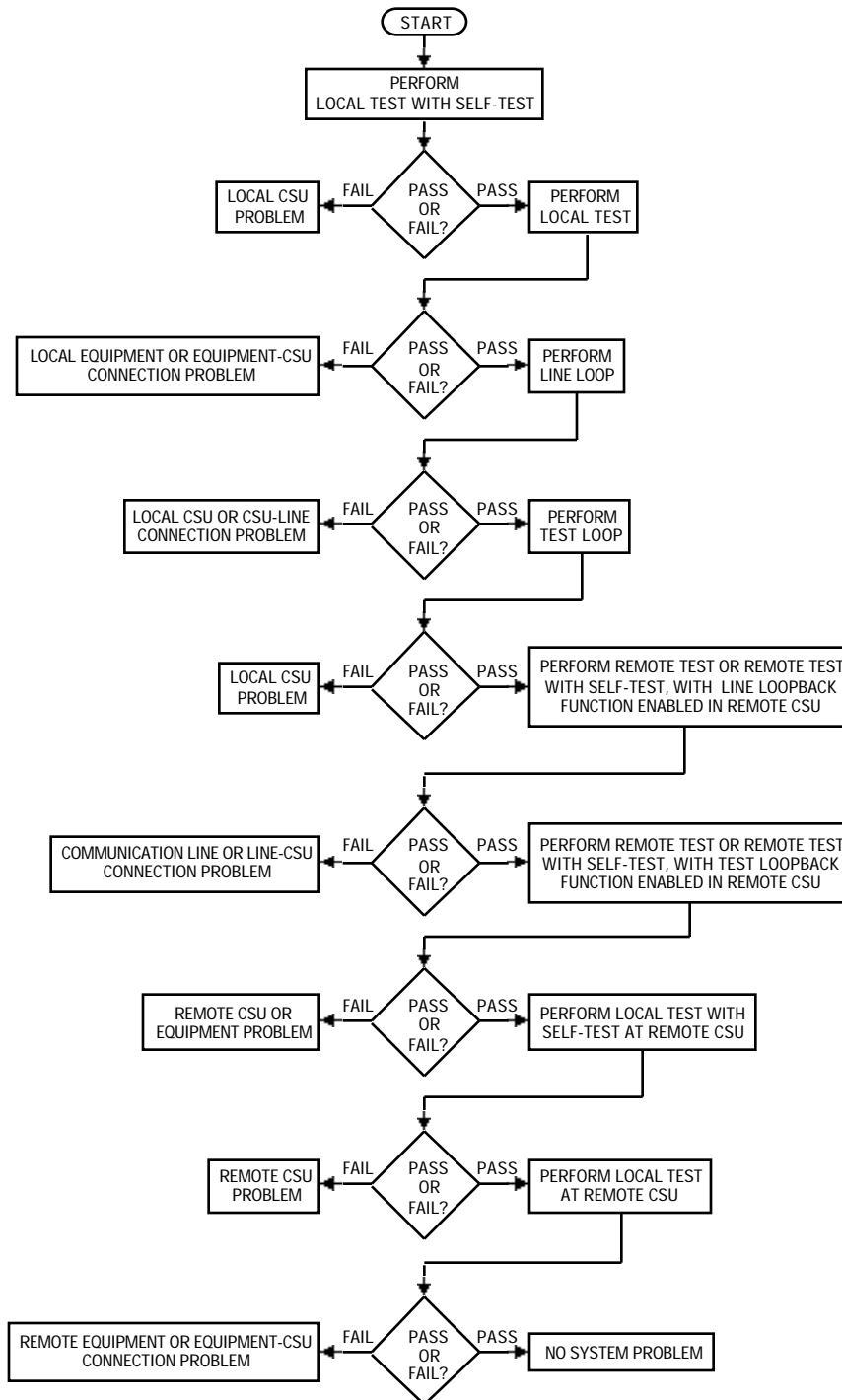

FIGURE 4-1. TROUBLE DIAGNOSTIC FLOWCHART

TESTS

DS1 LOOPBACK FUNCTIONS

The DS1 Line Loopback and DS1 Test Loopback functions, illustrated in Figure 4-2, allow the signal received from the network to be looped through the DSU's circuitry and transmitted back toward the network. These functions in themselves are not tests, but are used in conjunction with other DS1 diagnostic tests.

The DS1 Network Interface Loopback function allows the signal received from the network to be looped back toward the network at the Telco-provided DS1 Interface Connector (or Smart Jack). It is not normally used alone, but used in conjunction with external test equipment or with DS1 Self-Test.

Figure 4-2 also illustrates DS1 Local Test, Channel Digital Loop, and Channel Local Loop. These are discussed later, but illustrated here to show the scope of tests available.

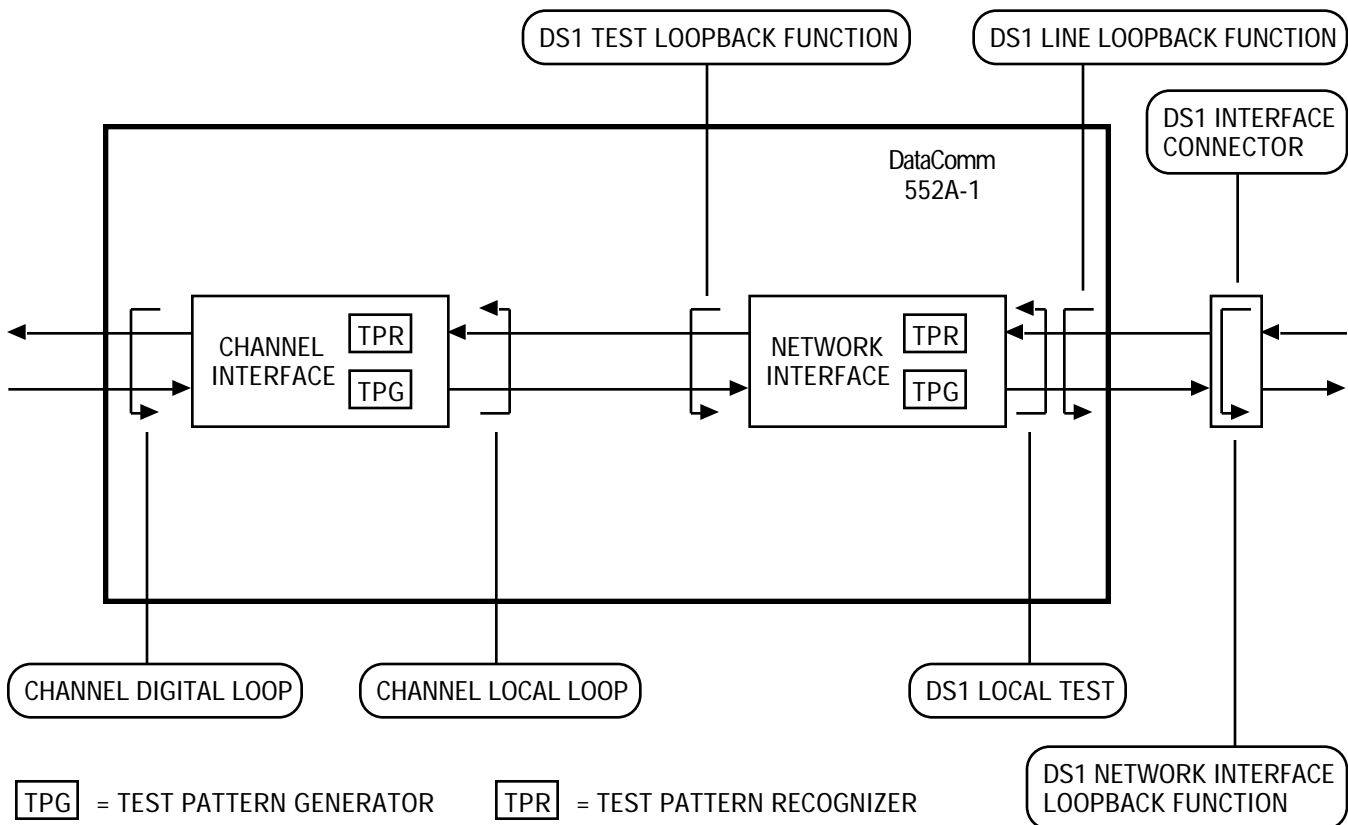

FIGURE 4-2. DS1 AND CHANNEL LOOPBACK FUNCTIONS

DS1 Line Loopback Function

The DS1 Line Loopback (LLB) function, illustrated in Figure 4-3, allows the signal received from the network to be looped through a minimum of the DSU's circuitry and transmitted back toward the network. Only the DSU's critical circuitry (the line build-out and timing regeneration circuits) is utilized, with bipolar violations uncorrected. This tests everything on the network side up to the DSU's critical circuitry.

The LLB function can be activated and deactivated locally via the Supervisory terminal, or remotely via loopback codes as defined in PUB 54016 (for Extended Superframe Format) or PUB 62411 (for D4 Superframe Format).

To allow remote activation and deactivation, the LLB function must be enabled via the Supervisory terminal or option switches S3-6 and S4-8.

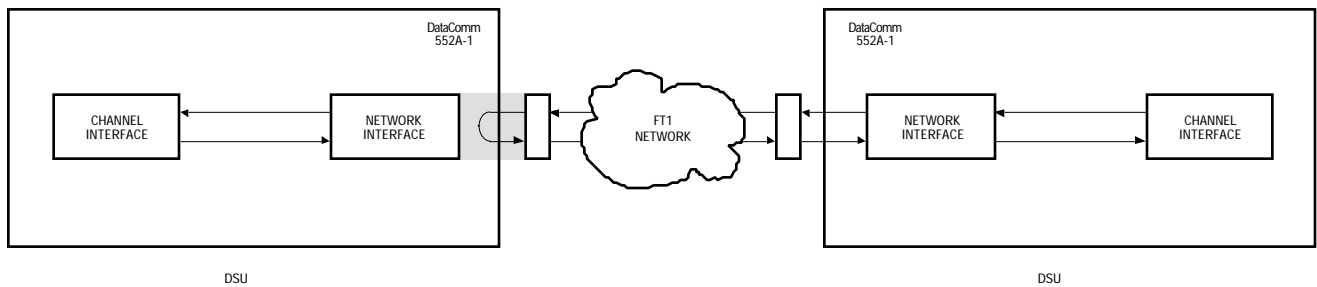

FIGURE 4-3. DS1 LINE LOOPBACK FUNCTION

TESTS

DS1 Network Interface Loopback Function

The DS1 Network Interface Loopback function, illustrated in Figure 4-4, allows the signal received from the network to be looped back toward the network at the DS1 Interface Connector (a Telco-provided connector installed on the network side intended to enhance maintenance operations). This tests everything on the network side up to the DS1 Interface Connector.

CAUTION

When connected to a DS1 Interface Connector (or Smart Jack), the DSU must be configured for manual Network Line Build-Out (consult the carrier for the proper attenuation level).

The DS1 Network Interface Loopback function can be activated and deactivated remotely via the Supervisory terminal or by the Telco, using loopback codes as defined in Bellcore TR-TSY-000312.

The DS1 Network Interface Loopback function is not normally used alone, but used in conjunction with DS1 Network Interface Loopback or DS1 Network Interface Loopback with Self-Test.

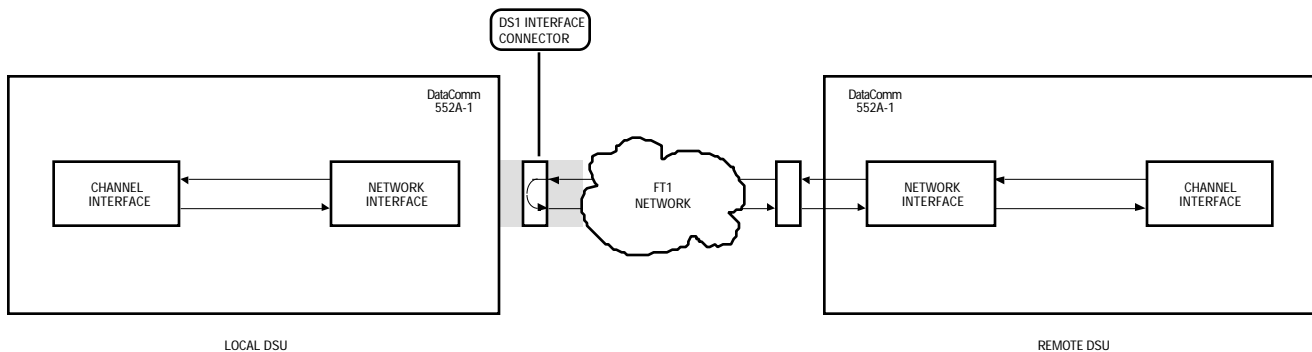

FIGURE 4-4. DS1 NETWORK INTERFACE LOOPBACK FUNCTION

DS1 Test Loopback Function

The DS1 Test Loopback (TLB) function, illustrated in Figure 4-5, allows the signal received from the network to be looped through as much as is practical of the DSU's circuitry and transmitted back toward the network. This tests everything on the network side up to and including the DSU. Framing is regenerated. Bipolar violations are corrected in both modes.

The TLB function can be activated and deactivated locally via the Supervisory terminal, or remotely via loopback codes as defined in PUB 54016 (for Extended Superframe Format).

To allow remote activation and deactivation, the TLB function must be enabled via the Supervisory terminal or option switches S3-6 and S4-8.

NOTE

In ANSI terminology, activation of this function is equivalent to Payload Loopback (PLB), described in Bellcore TR-TSY-000194. In PUB 54016 terminology, it is equivalent to DTE Loopback (DLB).

The TLB function cannot be used alone, but must be used in conjunction with one of the following tests: DS1 Test Loop, DS1 Remote Test, or DS1 Remote Test with Self-Test.

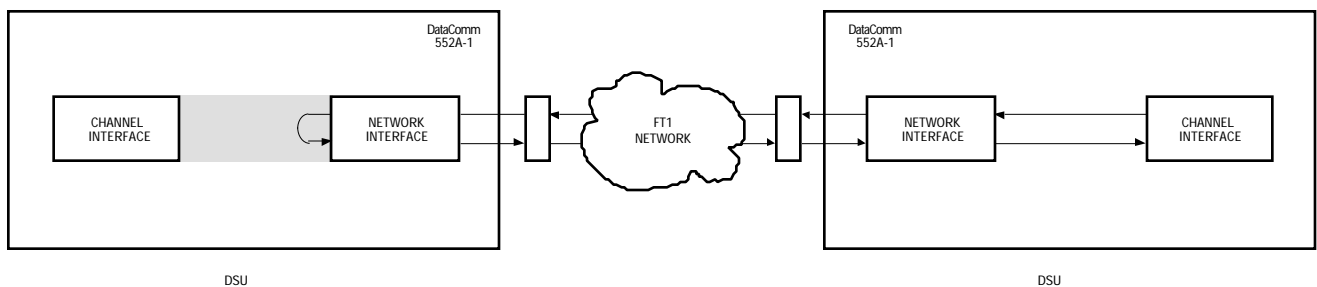

FIGURE 4-5. DS1 TEST LOOPBACK FUNCTION

TESTS

DS1 DIAGNOSTICS

The DS1 diagnostics described below include DS1-level diagnostic tests that affect the entire T1 link, or the DS1 (Digital Signal Level 1). Use these tests when you suspect that a problem is impairing data on all DS0s. Some of these tests can be controlled only via the Supervisory terminal, while others can also be controlled via the front panel switches.

NOTE

If you initiate a DS1 diagnostic while a DS0 diagnostic is in progress, the DS0 diagnostic is terminated.

DS1 Line Loop

DS1 Line Loop, illustrated in Figure 4-6, activates the local DSU's DS1 Line Loopback function. This tests the local DSU's network interface circuitry and the T1 link by transmitting a remotely-generated test message through the remote DSU to the local DSU and looping it back to the test equipment for verification. No minimum pulse density is maintained and bipolar violations are not corrected.

This test can be controlled only via the Supervisory terminal, using the Line Loop function. To perform this test, refer to Table 4-1.

TABLE 4-1. DS1 LINE LOOP

Step	Supervisory Terminal Control
1.	To prevent data loss, suspend operation of all associated digital-terminating equipment.
2.	Connect the test equipment to the remote DSU's test jacks, as shown.
3.	Initiate Line Loop at the local DSU (on the Loopbacks screen). Loop Status should be Line Loop during the test.
4.	Generate a test message. The test equipment should receive the same message it transmitted; if not, a problem exists.
5.	To stop the test, terminate Line Loop.

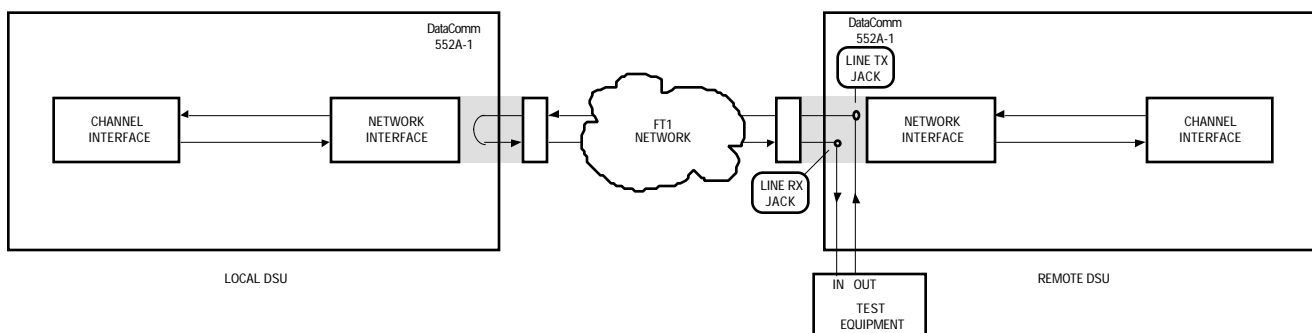

FIGURE 4-6. DS1 LINE LOOP

DS1 Line Loop with Self-Test

DS1 Line Loop with Self-Test, illustrated in Figure 4-7, activates the local DSU's DS1 Line Loopback function and the remote DSU's DS1 Self-Test. This tests the local DSU's network interface circuitry and the T1 link by transmitting an internally-generated test message from the remote DSU to the local DSU and looping it back for verification. No minimum pulse density is maintained.

This test can be controlled only via the Supervisory terminal, using the Line Loop function locally and Self Test remotely. To perform this test, refer to Table 4-2.

TABLE 4-2. DS1 LINE LOOP WITH SELF-TEST

Step	Supervisory Terminal Control
1.	To prevent data loss, suspend operation of all associated digital-terminating equipment.
2.	Initiate Line Loop at the local DSU (on the Loopbacks screen). Loop Status should be Line Loop during the test.
3.	Initiate Self-Test at the remote DSU (on the CSU Self Test screen).
4.	Monitor Test Results at the remote DSU for the averaged BER. A high BER indicates that a problem exists.
5.	To stop the test, terminate Self Test and then Line Loop.

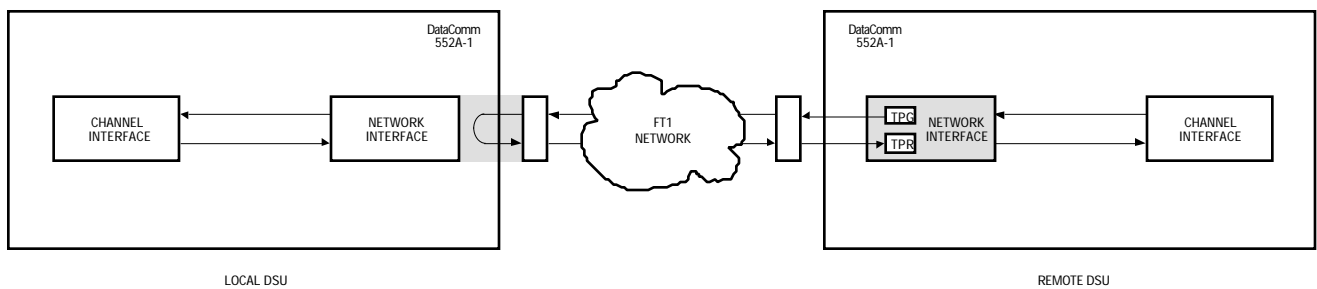

FIGURE 4-7. DS1 LINE LOOP WITH SELF-TEST

TESTS

DS1 Local Test

DS1 Local Test, illustrated in Figure 4-8, transmits a locally-generated test message through the DSU and looping it back (at the network interface) to the test equipment for verification. During this test, data is also transmitted to the T1 link, with pulse density constraints.

This test can be controlled locally via front panel switch T1 Test, or the Supervisory terminal Local Test. To perform this test, refer to Table 4-3.

TABLE 4-3. DS1 LOCAL TEST

Step	Front Panel Control	Supervisory Terminal Control
1.	To prevent data loss, suspend operation of all associated digital-terminating equipment.	
2.	Connect the test equipment to the local DSU, as shown.	
3.	Engage the local DSU's T1 TEST switch. The TM indicator should be lit during the test.	Initiate Local Test at the local DSU (on the Loopbacks screen).
4.	Generate a test message. The test equipment should receive the same message it transmitted; if not, a problem exists.	
5.	To stop the test, disengage the T1 TEST switch.	To stop the test, terminate Local Test.

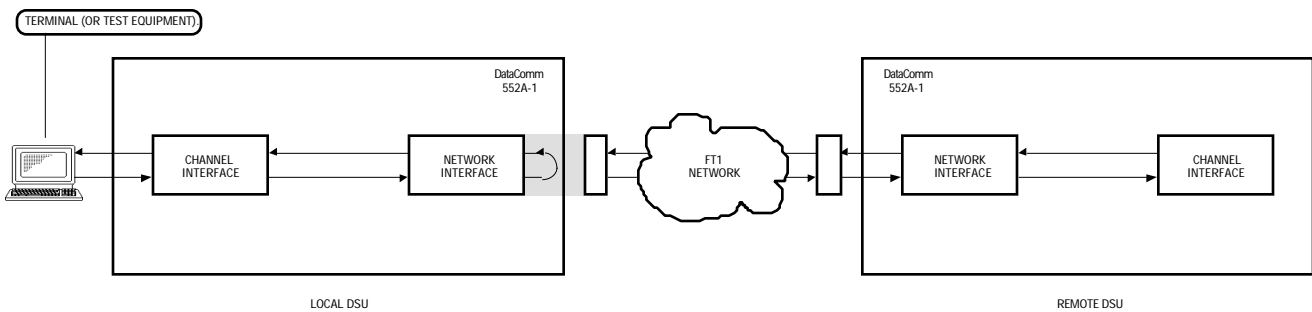

FIGURE 4-8. DS1 LOCAL TEST

DS1 Local Test with Self-Test

DS1 Local Test with Self-Test, illustrated in Figure 4-9, transmits an internally-generated test pattern through the DSU to test the DSU. During this test, data is also transmitted to the T1 link, with pulse density constraints. The test pattern is selected via the Supervisory terminal. Within the DSU, a Test Pattern Generator creates the test pattern, and a Test Pattern Recognizer determines if the data it receives matches that which was transmitted.

This test can be controlled locally via front panel switches T1 Test and Channel ST, or the Supervisory terminal, using Local Test and Self Test. To perform this test, refer to Table 4-4.

TABLE 4-4. DS1 LOCAL TEST WITH SELF-TEST

Step	Front Panel Control	Supervisory Terminal Control
1.	To prevent data loss, suspend operation of all associated digital-terminating equipment.	
2.	Connect the test equipment to the local DSU, as shown.	
3.	Engage the local DSU's T1 TEST and CHANNEL TEST ST switches. The TM indicator should be lit during the test.	Initiate Local Test at the local DSU (on the Loopbacks screen) and then Self-Test (on the CSU Self Test screen).
4.	Monitor Test Results for the averaged BER. A high BER indicates that a problem exists.	
5.	To stop the test, disengage the T1 TEST and CHANNEL TEST ST switches.	To stop the test, terminate Self-Test and then Local Test.

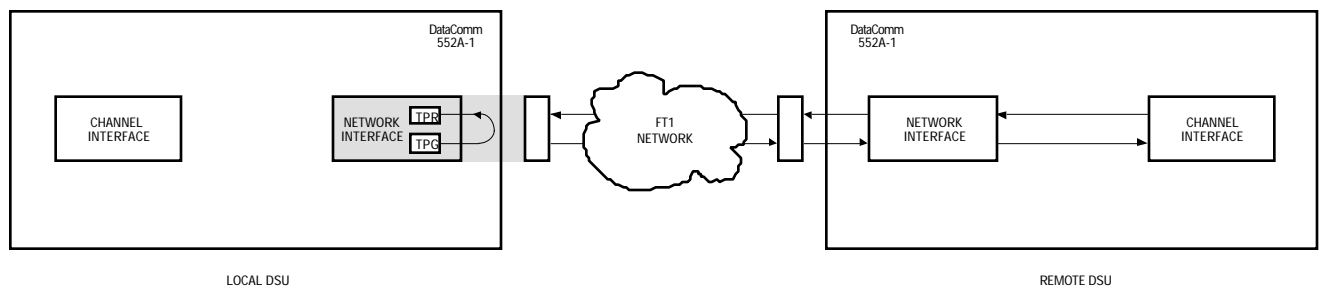

FIGURE 4-9. DS1 LOCAL TEST WITH SELF-TEST

TESTS

DS1 Network Interface Loopback

DS1 Network Interface Loopback, illustrated in Figure 4-10, tests the local DSU and the T1 link by transmitting a locally-generated test message through the local DSU to the remote DS1 Interface Connector and looping it back to the test equipment for verification. Whether the local DSU transmits framed or unframed loopback codes depends on the selection of the loopback test code framing option.

CAUTION

When connected to a DS1 Interface Connector (or Smart Jack), the DSU must be configured for manual Network Line Build-Out (consult the carrier for the proper attenuation level).

This test can only be controlled locally via the Supervisory terminal, using the NI Loop test. To perform this test, refer to Table 4-5.

TABLE 4-5. DS1 NETWORK INTERFACE LOOPBACK

Step	Supervisory Terminal Control
1.	To prevent data loss, suspend operation of all associated digital-terminating equipment.
2.	Initiate NI Loop at the local DSU (on the Loopbacks screen).
3.	Wait 5 seconds after starting the test, then connect the test equipment to the local DSU, as shown.
4.	Generate a test message. The test equipment should receive the same message it transmitted; if not, a problem exists.
5.	To stop the test, disconnect the test equipment, then terminate NI Loop.

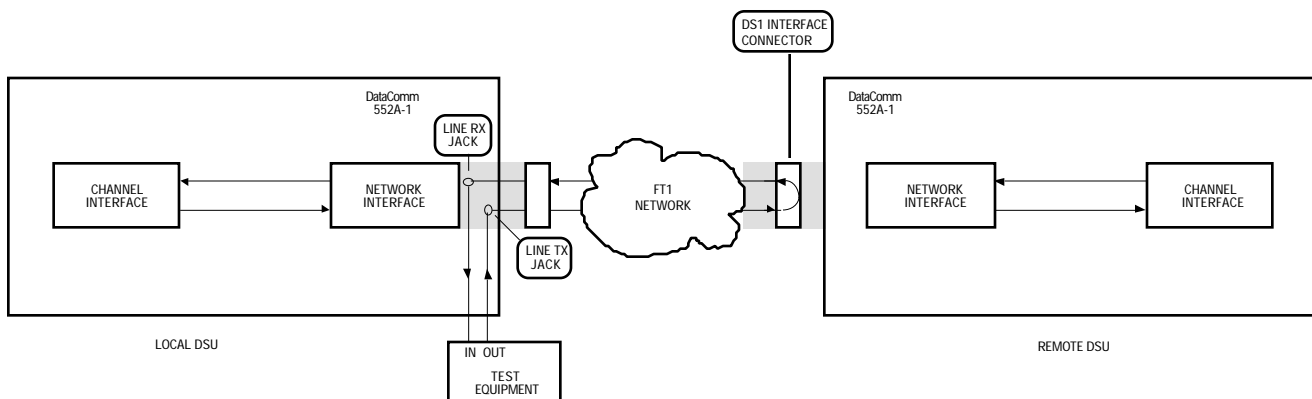

FIGURE 4-10. DS1 NETWORK INTERFACE LOOPBACK

DS1 Network Interface Loopback with Self-Test

DS1 Network Interface Loopback with Self-Test, illustrated in Figure 4-11, tests the local DSU and the T1 link by transmitting a local DSU-generated test pattern to the remote DS1 Interface Connector and looping it back for verification. The test pattern is selected via the Supervisory terminal. Within the local DSU, a Test Pattern Generator creates the test pattern, and a Test Pattern Recognizer determines if the data it receives matches that which was transmitted. Whether the local DSU transmits framed or unframed loopback codes depends on the selection of the loopback test code framing option.

CAUTION

When connected to a DS1 Interface Connector (or Smart Jack), the DSU must be configured for manual Network Line Build-Out (consult the carrier for the proper attenuation level).

This test can only be controlled locally via the Supervisory terminal, using NI Loop test and Self-Test. To perform this test, refer to Table 4-6.

TABLE 4-6. DS1 NETWORK INTERFACE LOOPBACK WITH SELF-TEST

Step	Supervisory Terminal Control
1.	To prevent data loss, suspend operation of all associated digital-terminating equipment.
2.	Initiate NI Loop at the local DSU (on the Loopbacks screen), and then select the desired test pattern and initiate Self-Test (on the CSU Self Test screen). The front panel TM indicator should light and the status line ST indicator should come on.
3.	Monitor Test Results for the averaged BER. A high BER indicates that a problem exists.
4.	To stop the test, terminate Self-Test and then NI Loop.

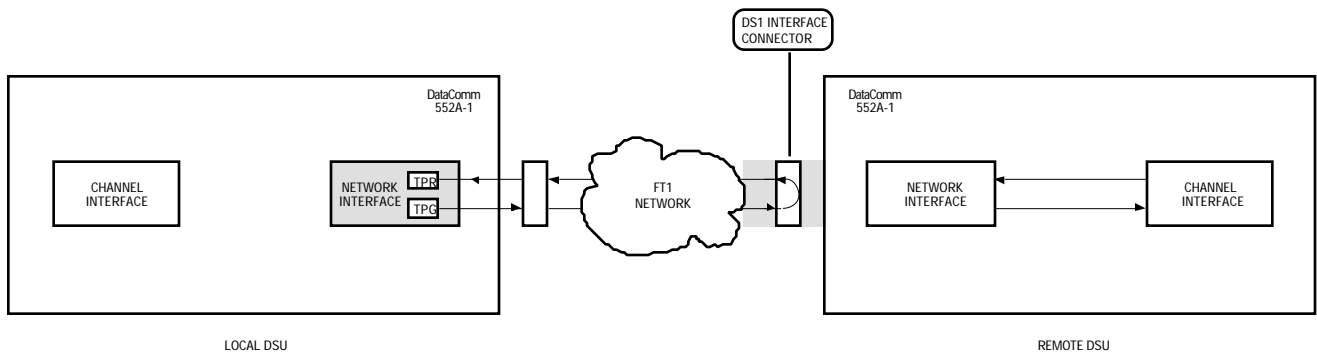

FIGURE 4-11. DS1 NETWORK INTERFACE LOOPBACK WITH SELF-TEST

TESTS

DS1 Remote Test

DS1 Remote Test (RT) activates the remote DSU's DS1 Line Loopback function (illustrated in Figure 4-12) or DS1 Test Loopback function (Figure 4-13), depending on which one is enabled in the remote DSU. This tests both DSUs and the T1 link by transmitting a locally-generated test message through the local DSU to the remote DSU and looping it back to the test equipment for verification. Bipolar violations are uncorrected during this test when the remote DSU has its LLB function enabled. Whether the local DSU transmits framed or unframed loopback codes depends on the selection of the loopback test code framing option.

NOTE

Initiating DS1 Remote Test causes the local DSU to send the loopback code to the remote DSU, and to reflect the local DSU's test status via its front panel and status line indicators. These indicators do not imply that the remote DSU is in loopback, as the remote DSU does not acknowledge receipt of loopback codes nor does it inform the local DSU of its test status. In-Band DS1 Loopback Code Detection must be enabled in the remote DSU.

This test can be controlled locally via front panel switches T1 TEST and CHANNEL TEST RDL, or the Supervisory terminal Remote Test. To perform this test, refer to Table 4-7.

TABLE 4-7. DS1 REMOTE TEST

Step	Front Panel Control	Supervisory Terminal Control
1.	To prevent data loss, suspend operation of all associated digital-terminating equipment.	
2.	Engage the local DSU's T1 TEST and CHANNEL TEST RDL switches. The TM indicator should be lit during the test.	Initiate Remote Test at the local DSU (on the Loopbacks screen). Loop Status should be Remote Loop during the test.
3.	Wait 5 seconds after starting the test, then connect the test equipment to the local DSU, as shown.	
4.	Generate a test message. The test equipment should receive the same message it transmitted; if not, a problem exists.	
5.	To stop the test, disconnect the test equipment, then disengage the T1 TEST and CHANNEL TEST RDL switches.	To stop the test, disconnect the test equipment, then terminate Remote Test.

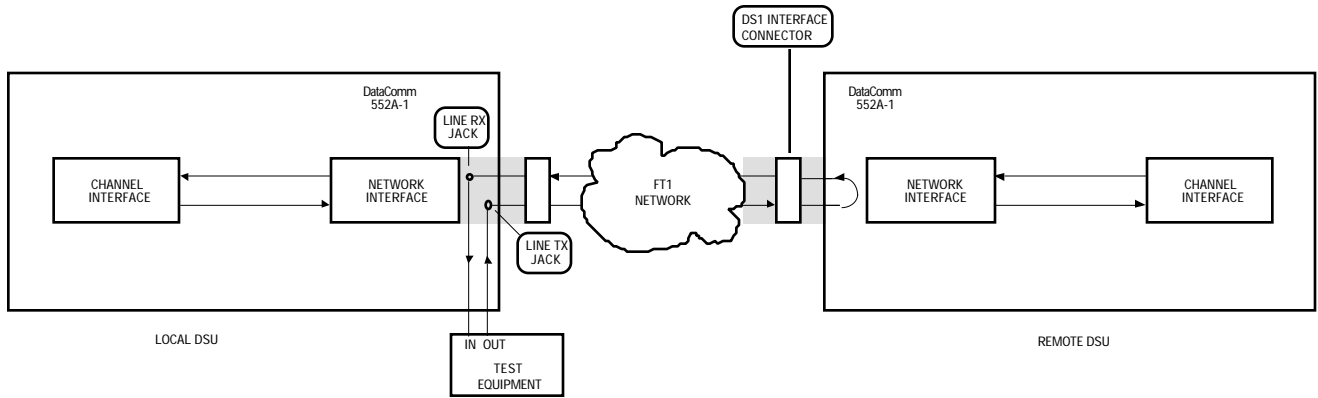

FIGURE 4-12. DS1 REMOTE TEST WITH LINE LOOPBACK

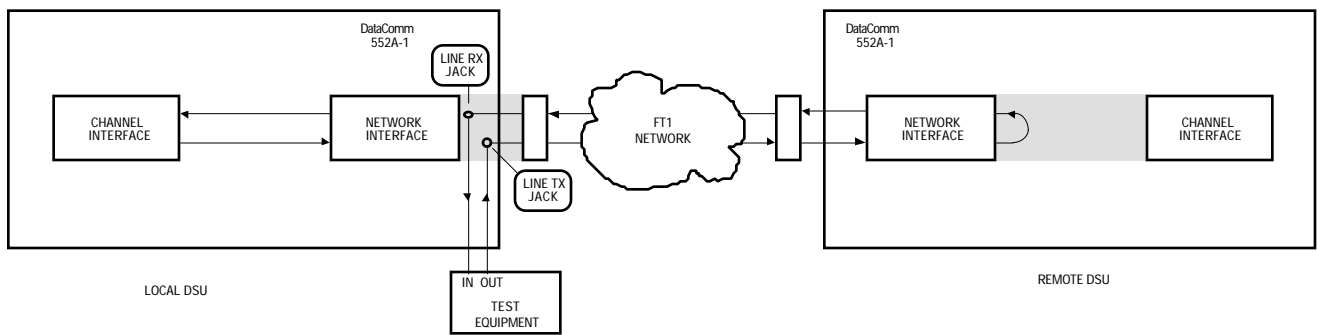

FIGURE 4-13. DS1 REMOTE TEST WITH TEST LOOPBACK

TESTS

DS1 Remote Test with Self-Test

DS1 Remote Test with Self-Test activates the remote DSU's DS1 Line Loopback function (illustrated in Figure 4-14) or DS1 Test Loopback function (Figure 4-15), depending on which one is enabled in the remote DSU. This tests both DSUs and the T1 link by transmitting a local DSU-generated test pattern to the remote DSU and looping it back for verification. The test pattern is selected via the Supervisory terminal. Within the local DSU, a Test Pattern Generator creates the test pattern, and a Test Pattern Recognizer determines if the data it receives matches that which was transmitted. Bipolar violations are not corrected during this test when the remote DSU has its LLB function enabled. Whether the local DSU transmits framed or unframed loopback codes depends on the selection of the loopback test code framing option.

NOTE

Initiating DS1 Remote Test with Self-Test causes the local DSU to send the loopback code and test pattern to the remote DSU, and to reflect the local DSU's test status via its front panel and status line indicators. These indicators do not imply that the remote DSU is in loopback, as the remote DSU does not acknowledge receipt of loopback codes nor does it inform the local DSU of its test status. In-Band DS1 Loopback Code Detection must be enabled in the remote DSU.

This test can only be controlled locally via the Supervisory terminal, using Remote Test and Self-Test. To perform this test, refer to Table 4-8.

TABLE 4-8. DS1 REMOTE TEST WITH SELF-TEST

Step	Supervisory Terminal Control
1.	To prevent data loss, suspend operation of all associated digital-terminating equipment.
2.	Initiate Remote Test at the local DSU (on the Loopbacks screen) and then Self-Test (on the CSU Self Test screen).
3.	Monitor Test Results for the averaged BER. A high BER indicates that a problem exists.
4.	To stop the test, terminate Self-Test and then Remote Test.

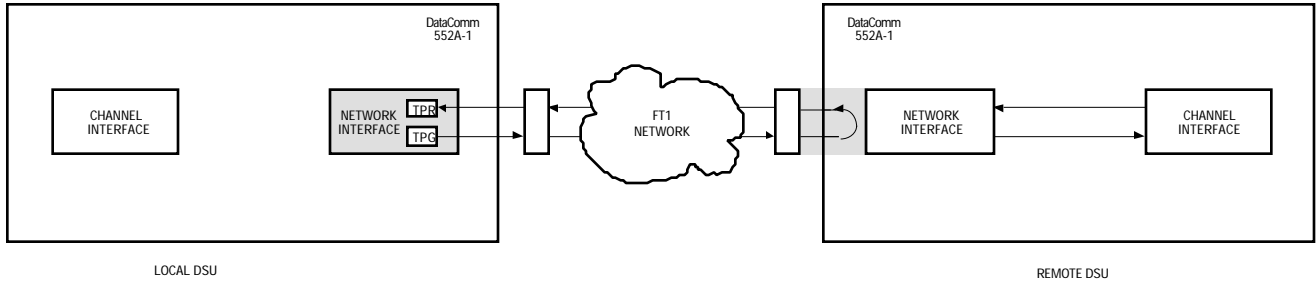

FIGURE 4-14. DS1 REMOTE TEST WITH SELF-TEST AND LINE LOOPBACK

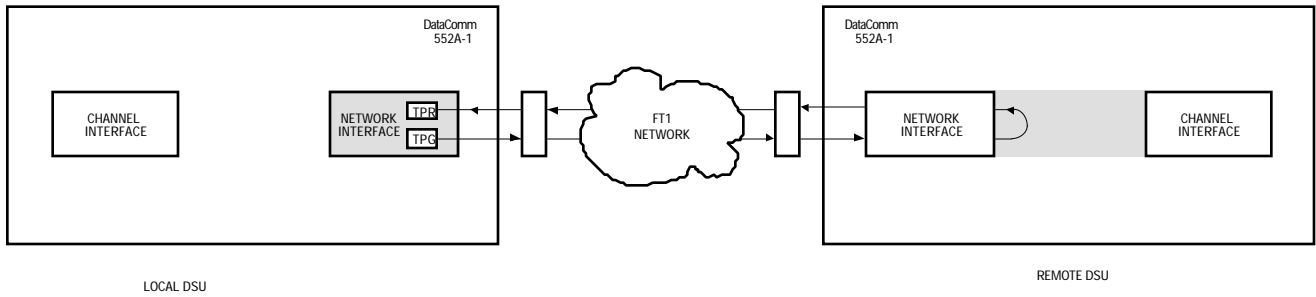

FIGURE 4-15. DS1 REMOTE TEST WITH SELF-TEST AND TEST LOOPBACK

TESTS

DS1 Self-Test

DS1 Self-Test (ST) causes the DSU to generate and verify a test pattern. The test pattern is selected via the Supervisory terminal. DS1 Self-Test can be used with DS1 Local Test (refer to DS1 Local Test with Self-Test), DS1 Remote Test (refer to DS1 Remote Test with Self-Test) or DS1 Network Interface Loopback (refer to DS1 Network Interface Loopback with Self-Test) to test one DSU, or alone as a DS1 End-to-End Self-Test.

DS1 End-to-End Self-Test, illustrated in Figure 4-16, tests both DSUs and the T1 link by transmitting a local DSU-generated test pattern to the remote DSU for verification, and vice versa. (Bipolar violations are corrected during this test.) Within each DSU, a Test Pattern Generator creates the test pattern, and a Test Pattern Recognizer determines if the data it receives matches that which was transmitted.

NOTE

To properly perform DS1 End-to-End Self-Test, both DSUs must be optioned for the same test pattern.

DS1 End-to-End Self-Test can be controlled only via the Supervisory terminal, using Self Test at each DSU. To perform this test, refer to Table 4-9.

TABLE 4-9. DS1 END-TO-END SELF-TEST

Step	Supervisory Terminal Control
1.	To prevent data loss, suspend operation of all associated digital-terminating equipment.
2.	Initiate Self Test (on the CSU Self Test screen) at both DSUs.
3.	Monitor Test Results for the averaged BER. A high BER indicates that a problem exists.
4.	To stop the test, terminate Self-Test at both DSUs.

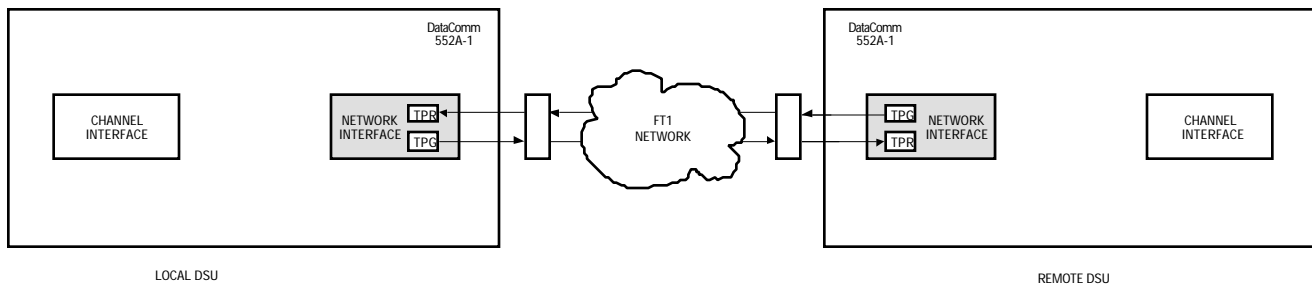

FIGURE 4-16. DS1 END-TO-END SELF-TEST

DS1 Test Loop

DS1 Test Loop, illustrated in Figure 4-17, activates the local DSU's DS1 Test Loopback function. This tests the local DSU and the T1 link by transmitting a remotely-generated test message through the remote DSU to the local DSU and looping it back to the test equipment for verification.

This test can be controlled only via the Supervisory terminal, using the DS1 Test Loop function. To perform this test, refer to Table 4-10.

TABLE 4-10. DS1 TEST LOOP

Step	Supervisory Terminal Control
1.	To prevent data loss, suspend operation of all associated digital-terminating equipment.
2.	Connect the test equipment to the remote DSU's test jacks, as shown.
3.	Initiate Test Loop at the local DSU (on the Loopbacks screen). Loop Status should be Test Loop during the test.
4.	Generate a test message. The test equipment should receive the same message it transmitted; if not, a problem exists.
5.	To stop the test, terminate Test Loop.

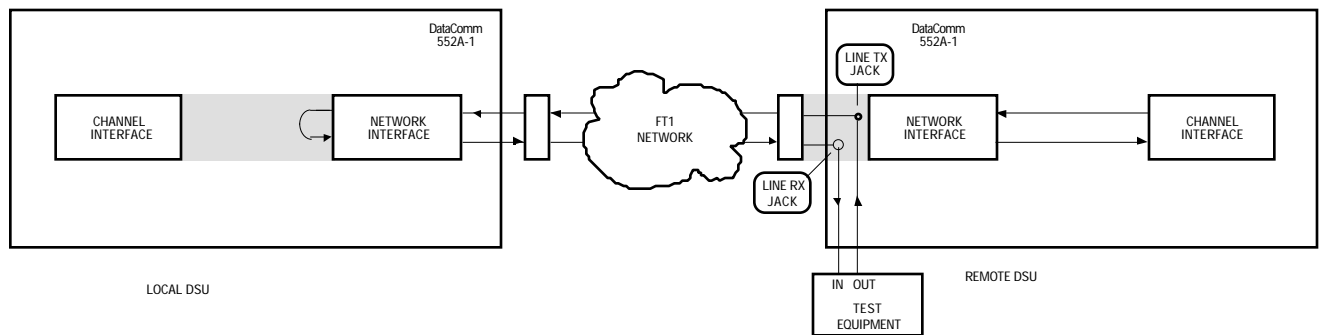

FIGURE 4-17. DS1 TEST LOOP

TESTS

DS1 Test Loop with Self-Test

DS1 Test Loop with Self-Test, illustrated in Figure 4-18, activates the local DSU's DS1 Test Loopback function and the remote DSU's DS1 Self-Test. This tests the local DSU and the T1 link by transmitting an internally-generated test message from the remote DSU to the local DSU and looping it back for verification.

This test can be controlled only via the Supervisory terminal, using the DS1 Test Loop function locally and Self Test remotely. To perform this test, refer to Table 4-11.

TABLE 4-11. DS1 TEST LOOP WITH SELF-TEST

Step	Supervisory Terminal Control
1.	To prevent data loss, suspend operation of all associated digital-terminating equipment.
2.	Initiate Test Loop at the local DSU (on the Loopbacks screen). Loop Status should be Test Loop during the test.
3.	Initiate Self-Test at the remote DSU (on the CSU Self Test screen).
4.	Monitor Test Results at the remote DSU for the averaged BER. A high BER indicates that a problem exists.
5.	To stop the test, terminate Test Loop and then Self Test.

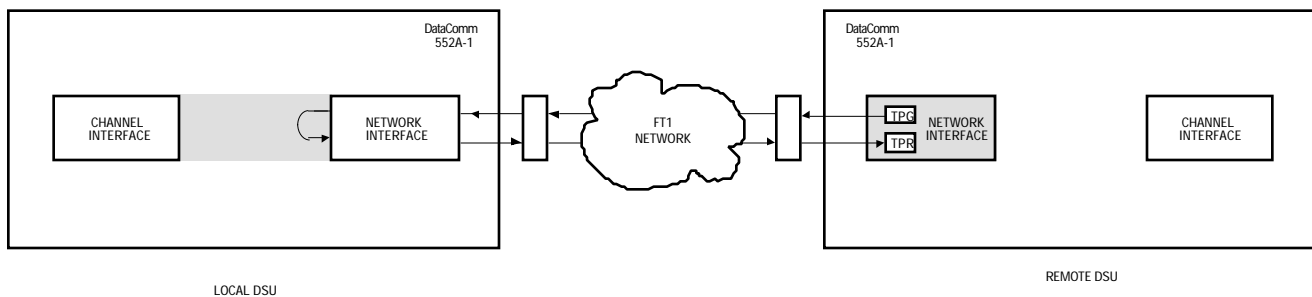

FIGURE 4-18. DS1 TEST LOOP WITH SELF-TEST

DS0 DIAGNOSTICS

The DS0 diagnostics described below include DS0-level diagnostic tests that affect a single DS0 (Digital Signal Level 0). Use these tests when you suspect that a problem is impairing data only on an isolated DS0. Only one test, on one of the 24 DS0s, can be performed at a time. A DS0 diagnostic affects only the selected DS0. These tests can be controlled only via the Supervisory terminal.

CAUTION

All DS0 diagnostic functions for the remote DSU must be controlled using only out-of-band communications.

NOTE

You cannot initiate a DS0 diagnostic while a DS1 diagnostic is in progress.

DS0 Circuit Delay Measurement Test

DS0 Circuit Delay Measurement Test, illustrated in Figure 4-19, computes the round trip (from the local DSU to the remote DSU and back) transmission delay for the selected DS0, using an internally-generated message. Transmission delay includes many variables, such as circuit distance, transmission path (terrestrial vs. satellite, primary vs. alternate route), etc. For this reason, no absolute figures of acceptable delay are given here. Use the test result as an indication of network response time and throughput, and compare it to the result of the same test repeated at other times under similar conditions.

To perform this test, refer to Table 4-12.

TABLE 4-12. DS0 CIRCUIT DELAY MEASUREMENT TEST

Step	Supervisory Terminal Control
1.	To prevent data loss, suspend operation of all associated digital-terminating equipment on the DS0 to be tested.
2.	At the remote DSU, select the desired DS0, select LOOPBACK mode, and then initiate the test (all on the DS0 DIAGNOSTICS screen).
3.	At the local DSU, select the same DS0, select DELAY TEST mode, and then initiate the test (all on the DS0 DIAGNOSTICS screen).
4.	At the local DSU, the delay (in ms) is displayed in the Circuit Delay result field. The local DSU automatically stops its test.
5.	To stop the test, terminate LOOPBACK at the remote DSU.

TESTS

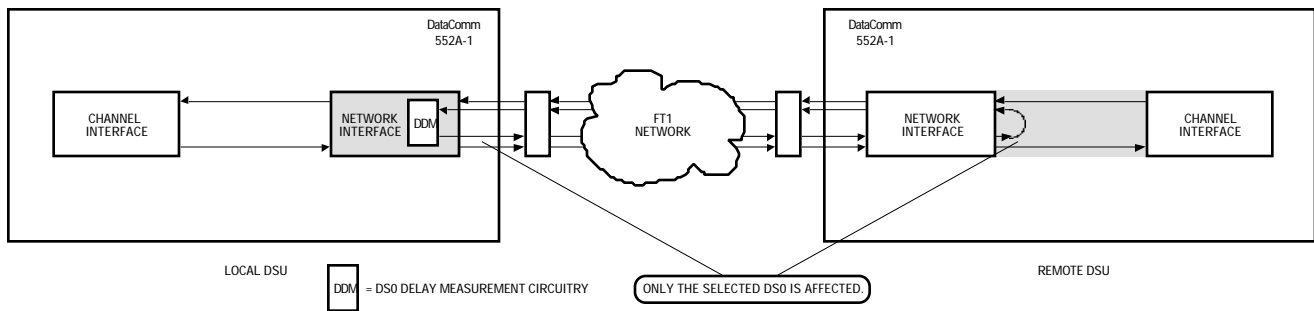

FIGURE 4-19. DS0 CIRCUIT DELAY MEASUREMENT TEST

DS0 Remote Test

DS0 Remote Test, illustrated in Figure 4-20, tests both DSUs and the T1 link by transmitting, on the selected DS0, a locally-generated test message through the local DSU to the remote DSU and looping it back to the test equipment for verification.

To perform this test, refer to Table 4-13.

TABLE 4-13. DS0 REMOTE TEST

Step	Supervisory Terminal Control
1.	To prevent data loss, suspend operation of all associated digital-terminating equipment on the DS0 to be tested.
2.	Connect the test equipment to the local DS0 to be tested, as shown.
3.	At the remote DSU, select the desired DS0, select LOOPBACK mode, and then initiate the test (all on the DS0 DIAGNOSTICS screen).
4.	Generate a test message. The test equipment should receive the same message it transmitted; if not, a problem exists.
5.	To stop the test, terminate LOOPBACK.

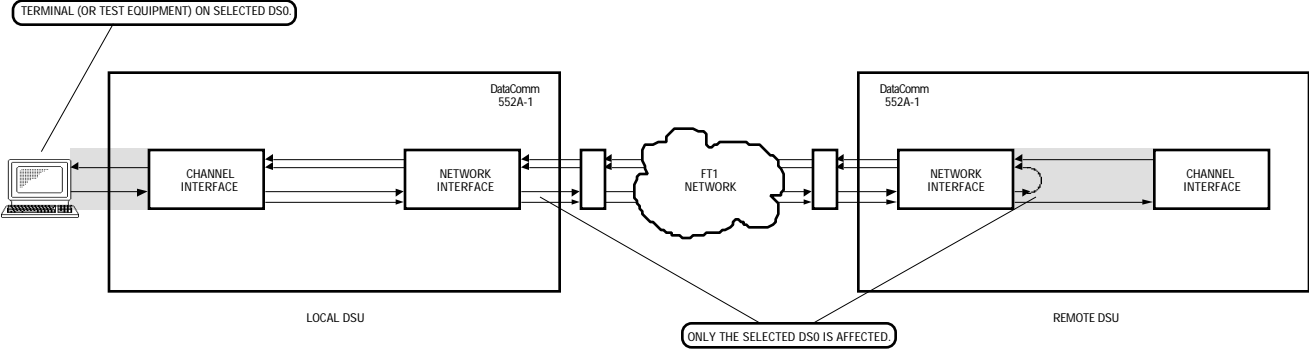

FIGURE 4-20. DS0 REMOTE TEST

TESTS

DS0 Remote Test with Self-Test

DS0 Remote Test with Self-Test, illustrated in Figure 4-21, tests both DSUs and the T1 link by transmitting, on the selected DS0, a local DSU-generated test pattern to the remote DSU and looping it back for verification. The test pattern is selected via the Supervisory terminal. Within the local DSU, a Test Pattern Generator creates the test pattern, and a Test Pattern Recognizer determines if the data it receives matches that which was transmitted.

To perform this test, refer to Table 4-14.

TABLE 4-14. DS0 REMOTE TEST WITH SELF-TEST

Step	Supervisory Terminal Control
1.	To prevent data loss, suspend operation of all associated digital-terminating equipment on the DS0 to be tested.
2.	At the remote DSU, select the desired DS0, select LOOPBACK mode, and then initiate the test (all on the DS0 DIAGNOSTICS screen).
3.	At the local DSU, select the test pattern and the same DS0, select BIT ERROR TEST mode, and then initiate the test (all on the DS0 DIAGNOSTICS screen). The front panel TM indicator should light and the status line ST indicator should come on.
4.	At the local DSU, any errors are displayed the Cumulative Errors field and the front panel ERR/ALM indicator lights. A high error count indicates that a problem exists.
5.	To stop the test, terminate BIT ERROR TEST and then LOOPBACK.

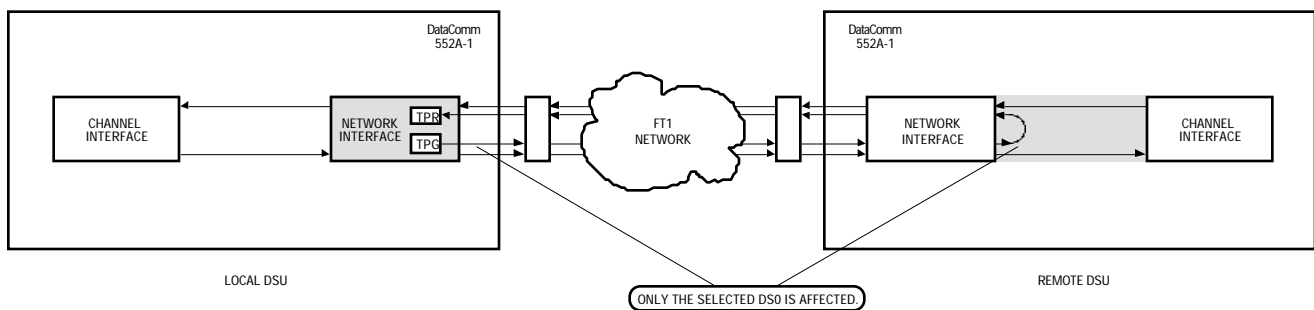

FIGURE 4-21. DS0 REMOTE TEST WITH SELF-TEST

DS0 Self-Test

DS0 Self-Test causes the DSU to generate and verify a test pattern on the selected DS0. The test pattern is selected via the Supervisory terminal. DS0 Self-Test can be used with DS0 Remote Test (refer to DS0 Remote Test with Self-Test) to test primarily the T1 link and the remote DSU, or alone as DS0 End-to-End Self-Test to also test the local DSU.

DS0 End-to-End Self-Test, illustrated in Figure 4-22, tests both DSUs and the T1 link by transmitting, on the selected DS0, a local DSU-generated test pattern to the remote DSU for verification, and vice versa. (Bipolar violations are corrected during this test.) Within each DSU, a Test Pattern Generator creates the test pattern, and a Test Pattern Recognizer determines if the data it receives matches that which was transmitted.

NOTE

To properly perform DS0 End-to-End Self-Test, you must select the same DS0 and test pattern at both DSUs.

To perform this test, refer to Table 4-15.

TABLE 4-15. DS0 END-TO-END SELF-TEST

Step	Supervisory Terminal Control
1.	To prevent data loss, suspend operation of all associated digital-terminating equipment on the DS0 to be tested.
2.	At the remote DSU, select the desired DS0 and test pattern, select BIT ERROR TEST mode, and then initiate the test (all on the DS0 DIAGNOSTICS screen). The front panel TM indicator should light and the status line ST indicator should come on.
3.	At the local DSU, select the same DS0 and test pattern, select BIT ERROR TEST mode, and then initiate the test (all on the DS0 DIAGNOSTICS screen). The front panel TM indicator should light and the status line ST indicator should come on.
4.	At the local DSU, any errors for the remote-to-local leg are displayed in its Cumulative Errors field and its front panel ERR/ALM indicator lights. At the remote DSU, any errors for the local-to-remote leg are displayed in its Cumulative Errors field and its front panel ERR/ALM indicator lights. A high error count indicates that a problem exists.
5.	To stop the test, terminate the tests at both DSUs.

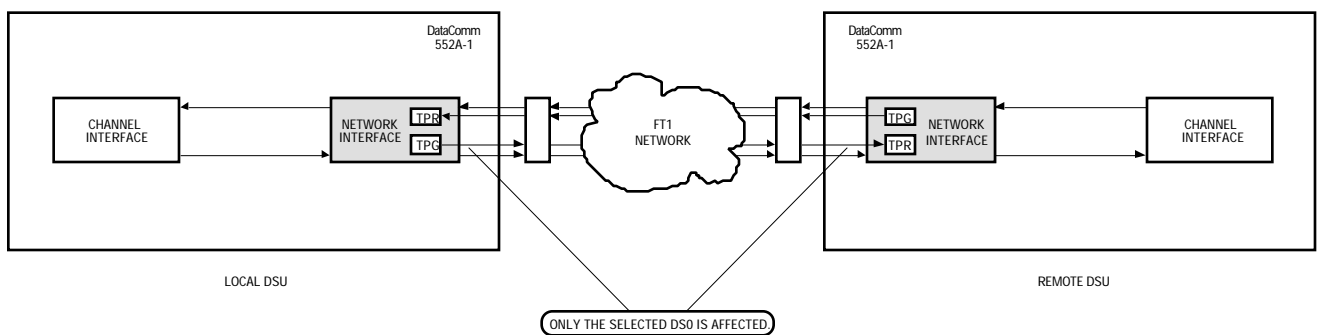

FIGURE 4-22. DS0 END-TO-END SELF-TEST

TESTS

CHANNEL DIAGNOSTICS

The channel diagnostics described below include channel-level diagnostic tests that affect the customer equipment signal on the channel. Use these tests when you suspect that a problem is impairing data on the channel. All of these tests can be controlled via the Supervisory terminal or the front panel switches.

NOTE

The DSU uses proprietary in-band loopback codes for controlling diagnostic channel tests. The binary loop-up code that puts the channel in loopback is "1100000" and the loop-down code that takes it out of loopback is "1110000."

Channel Digital Loop

Channel Digital Loop, illustrated in Figure 4-23, tests the remote channel equipment, both DSUs, and the T1 link. It does so by transmitting a remotely-generated test message through the remote DSU to the local DSU, looping it back at the local channel interface, and returning it to the test equipment for verification.

This test can be controlled locally via front panel switch CHANNEL TEST DL, the Supervisory terminal Digital Loop test or a control pin on the channel interface connector (except when using the optional EIA-530 Channel Interface Card), or remotely via loopback codes received from the network. To perform this test, refer to Table 4-16.

TABLE 4-16. CHANNEL DIGITAL LOOP

Step	Front Panel Control	Supervisory Terminal Control	Interface Control
1.	To prevent data loss, suspend operation of all associated digital-terminating equipment on the channel.		
2.	Connect the test equipment to the remote channel to be tested, as shown.		
3.	At the local DSU, engage the CHANNEL TEST DL switch. The TM and CHANNEL LB indicators should be lit during the test.	At the local DSU, initiate Digital Loop (on the CHANNEL DIAGNOSTICS screen). The status line DL indicator should display X.	At the local DSU, turn ON the DL to Remote lead: CCITT V.35 pin CC The Test Mode Status lead should turn ON: CCITT V.35 pin K
4.	Generate a test message. The test equipment should receive the same message it transmitted; if not, a problem exists.		
5.	To stop the test, disengage the CHANNEL TEST DL switch.	To stop the test, terminate Digital Loop.	To stop the test, turn OFF the DL to Remote lead.

TESTS

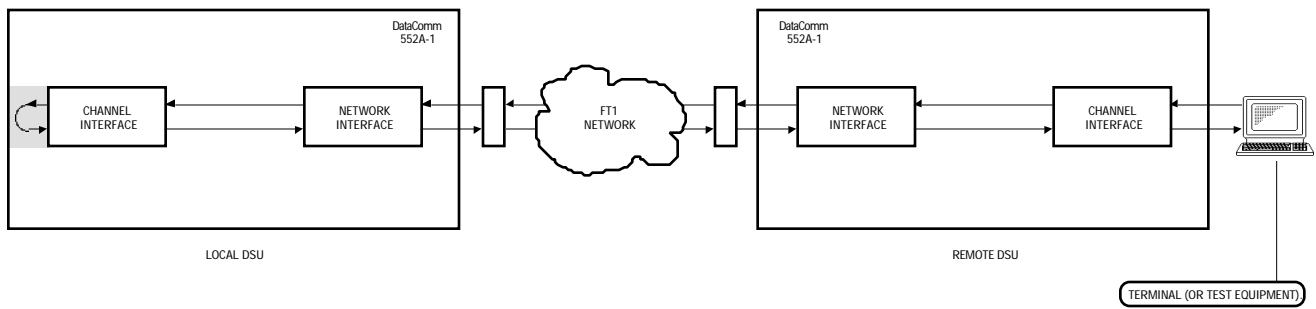

FIGURE 4-23. CHANNEL DIGITAL LOOP

Channel Local Loop

Channel Local Loop, illustrated in Figure 4-24, tests the local channel equipment and the local DSU. It does so by transmitting a locally-generated test message through the local DSU, looping it back at the local multiplexer interface, and returning it to the test equipment for verification.

This test can be controlled locally via front panel switches CHANNEL TEST RDL and CHANNEL TEST DL, the Supervisory terminal Local Loop test or a control pin on the channel interface connector (except when using the optional EIA-530 Channel Interface Card). To perform this test, refer to Table 4-17.

TABLE 4-17. CHANNEL LOCAL LOOP

Step	Front Panel Control	Supervisory Terminal Control	Interface Control
1.	To prevent data loss, suspend operation of all associated digital-terminating equipment on the channel.		
2.	Connect the test equipment to the remote channel to be tested, as shown.		
3.	At the local DSU, engage the CHANNEL TEST RDL and CHANNEL TEST DL switches. The TM and CHANNEL LB indicators should be lit during the test.	At the local DSU, initiate Local Loop (on the CHANNEL DIAGNOSTICS screen). The status line LL indicator should display X.	At the local DSU, turn ON the Local Loop lead: CCITT V.35 pin L RS-449 pin 10 The Test Mode Status lead should turn ON: CCITT V.35 pin K RS-449 pin 18
4.	Generate a test message. The test equipment should receive the same message it transmitted; if not, a problem exists.		
5.	To stop the test, disengage the CHANNEL TEST RDL and CHANNEL TEST DL switches.	To stop the test, terminate Local Loop.	To stop the test, turn OFF the Local Loop lead.

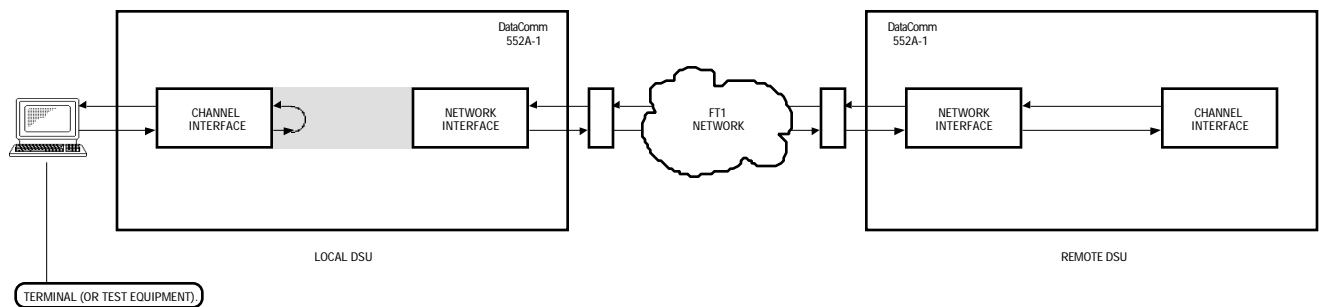

FIGURE 4-24. CHANNEL LOCAL LOOP

TESTS

Channel Remote Digital Loop

Channel Remote Digital Loop, illustrated in Figure 4-25, tests the local channel equipment, both DSUs, and the T1 link. It does so by transmitting a locally-generated test message through the local DSU to the remote DSU, looping it back at the remote channel interface, and returning it to the test equipment for verification. Loopback of the remote channel is controlled by in-band loopback codes transmitted by the local DSU after you start or stop the test.

The DSU uses either fixed or scrambled loopback codes. The fixed 7-bit binary loop-up code that puts the channel in loopback is "1100000" and the loop-down code that takes it out of loopback is "1110000," with a delay of five seconds. The scrambled code is generated by the polynomial $1 + x^3 + x^7$, similar to that used in PN-127, and the code is sent for two seconds. In the event the DSU does not loop up or loop down, it is likely there are channel errors. The type of code is set via option switch S12-1, or via the RDL Inband Code function on the Channel Diagnostics screen, and must be the same for both DSUs.

NOTE

Use of the PN-127 scrambled code is recommended for the 552A-1. However, because the DataComm 552 DOES NOT support PN-127, you must use fixed codes for the 552A-1 when a 552 is on the other end of the link.

This test can be controlled locally via front panel switch CHANNEL TEST RDL, the Supervisory terminal Remote Digital Loop test or a control pin on the channel interface connector, or remotely via loopback codes received from the network. To perform this test, refer to Table 4-18.

TABLE 4-18. CHANNEL REMOTE DIGITAL LOOP

Step	Front Panel Control	Supervisory Terminal Control	Interface Control
1.	To prevent data loss, suspend operation of all associated digital-terminating equipment on the channel.		
2.	Connect the test equipment to the local channel to be tested, as shown.		
3.	At the local DSU, engage the CHANNEL TEST RDL switch. The TM indicator should be lit during the test.	At the local DSU, initiate Remote Digital Loop (on the CHANNEL DIAGNOSTICS screen). The status line RDL indicator should display X.	At the local DSU, turn ON the Remote Digital Loop Enable lead: CCITT V.35 pin BB EIA-530 pin 21 RS-449 pin 14 The Test Mode Status lead should turn ON: CCITT V.35 pin K EIA-530 pin 25 RS-449 pin 18
4.	After starting the test, wait for the delay indicated above, then generate a test message. The test equipment should receive the same message it transmitted; if not, a problem exists.		
5.	To stop the test, disengage the CHANNEL TEST RDL switch.	To stop the test, terminate Remote Digital Loop.	To stop the test, turn OFF the Remote Digital Loop Enable lead.

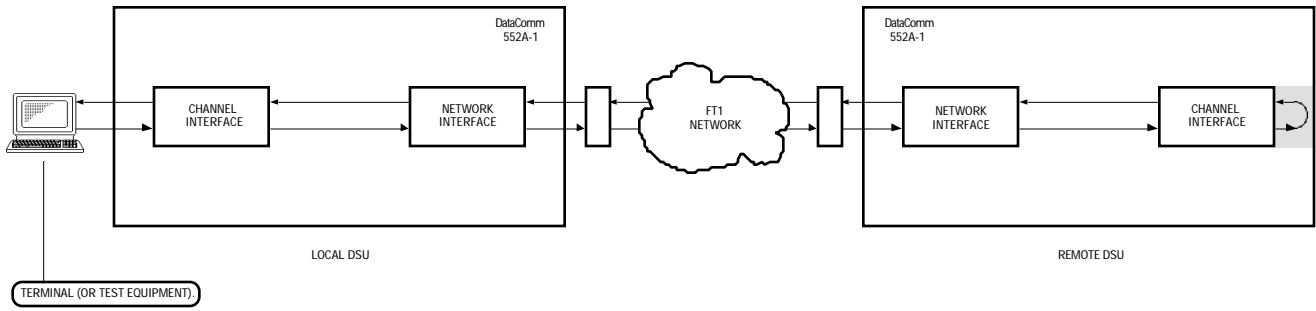

FIGURE 4-25. CHANNEL REMOTE DIGITAL LOOP

TESTS

Channel Remote Digital Loop with Self-Test

Channel Remote Digital Loop with Self-Test, illustrated in Figure 4-26, tests DSUs and the T1 link. It does so by transmitting a local DSU-generated test pattern through the local DSU to the remote DSU, looping it back at the remote channel interface, and returning it to the local DSU for verification. Loopback of the remote channel is controlled by in-band loopback codes transmitted by the local DSU after you start or stop the test.

This test can be controlled locally via front panel switches CHANNEL TEST RDL and CHANNEL TEST ST, the Supervisory terminal Self Test or a control pin on the channel interface connector (except when using the optional EIA-530 Channel Interface Card), or remotely via loopback codes received from the network. To perform this test, refer to Table 4-19.

TABLE 4-19. CHANNEL REMOTE DIGITAL LOOP WITH SELF-TEST

Step	Front Panel Control	Supervisory Terminal Control	Interface Control
1.	To prevent data loss, suspend operation of all associated digital-terminating equipment on the channel.		
2.	At the local DSU, engage the CHANNEL TEST RDL and CHANNEL TEST ST switches. The TM indicator should be lit during the test.	At the local DSU, select Remote Digital Loop, and then initiate Self Test (all on the CHANNEL DIAGNOSTICS screen). The front panel TM indicator should light and the status line RDL and ST indicators should display X.	At the local DSU, turn ON the Remote Digital Loop Enable lead: CCITT V.35 pin BB RS-449 pin 14 The Test Mode Status lead should turn ON: CCITT V.35 pin K RS-449 pin 18 Initiate Self-Test from either the front panel or the Supervisory terminal.
3.	At the local DSU, any errors are displayed the Self Test Status field and the front panel CHANNEL ERR indicator lights. A high error count indicates that a problem exists.		
4.	To stop the test, disengage the CHANNEL TEST RDL and CHANNEL TEST ST switches.	To stop the test, terminate Self Test and then Remote Digital Loop.	To stop the test, turn OFF the Self-Test lead and then the Remote Digital Loop Enable lead.

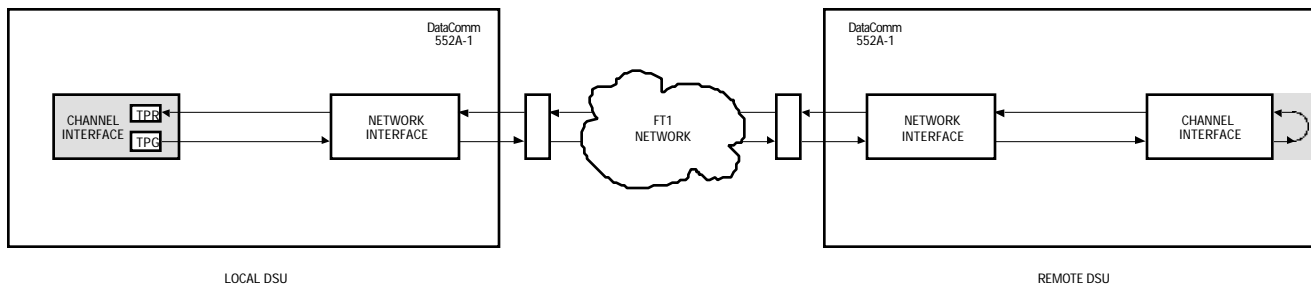

FIGURE 4-26. CHANNEL REMOTE DIGITAL LOOP WITH SELF-TEST

Channel Self-Test

Channel Self-Test causes the DSU to generate and verify a 511-bit test pattern. Channel Self-Test can be used with Channel Remote Digital Loop (refer to Channel Remote Digital Loop with Self-Test) or alone as a Channel End-to-End Self-Test.

Channel End-to-End Self-Test, illustrated in Figure 4-27, tests both DSUs and the T1 link by transmitting a local DSU-generated test pattern to the remote DSU for verification, and vice versa. (Bipolar violations are corrected during this test.) Within each DSU, a Test Pattern Generator creates the test pattern, and a Test Pattern Recognizer determines if the data it receives matches that which was transmitted.

This test can be controlled locally via front panel switch CHANNEL TEST ST, the Supervisory terminal Self Test, or a control pin on the channel interface connector (except when using the optional EIA-530 Channel Interface Card). To perform this test, refer to Table 4-20.

TABLE 4-20. CHANNEL END-TO-END SELF-TEST

Step	Front Panel Control	Supervisory Terminal Control
1.	To prevent data loss, suspend operation of all associated digital-terminating equipment on the channel.	
2.	At both DSUs, engage the CHANNEL TEST ST switch. The TM indicators should be lit during the test.	At both DSUs, initiate Self Test (on the CHANNEL DIAGNOSTICS screen). The front panel TM indicators should light and the status line channel ST indicators should display X.
3.	At each DSU, any errors are displayed the Self Test Status field and the front panel CHANNEL ERR indicator lights. A high error count indicates that a problem exists.	
4.	To stop the test, disengage the CHANNEL TEST ST switches at both DSUs.	To stop the test, terminate Self Test at both DSUs.

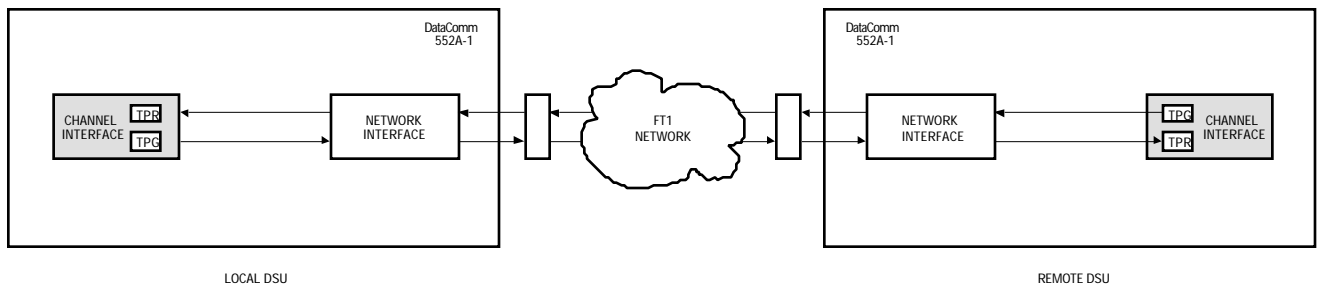

FIGURE 4-27. CHANNEL END-TO-END SELF-TEST

TESTS

TECHNICAL ASSISTANCE PROCEDURE

For technical assistance, customers should call DataComm Service Corporation at 203-598-7526.

In Canada:

General DataComm (Canada) Ltd.
Service and Repair Facility
1790 Beaulac Street
St. Laurent, Montreal, Quebec H4R 1W8
Telephone: 1-514-336-5454
TWX: 610-421-3221
Telex: 05824085

In the United Kingdom, contact the GDC area manager at:

General DataComm (U.K.) Ltd.
Molly Millars Close
Molly Millars Lane
Wokingham, Berkshire
England RG11 2QD
Telephone: 44-734-774-868
Telex: 851 847298

In Europe/Africa/Middle East:

General DataComm
3 Batiment Saturne
Parc Club Ariane
Rue Helene Boucher
78284 Guyancourt Cedex, France
Tel: 011-33-13-0570200
Fax: 011-33-13-0443794

In the Pacific:

General DataComm Pty.
Suite 404
275 Alfred Street North
North Sydney, NSW 2060, Australia
Tel: 011-61-2-956-5099

In Asia:

General DataComm
Room No. 2304, 23rd Floor
Tung Wai Commercial Building
109-111 Gloucester Road
Wanchai, Hong Kong
Tel: 011-852-8336779
Telex: 780-80579

In Latin America:

General DataComm, International
1579 Straits Turnpike
P.O. Box 1299
Middlebury, Connecticut 06762-1299
Telephone: 203-574-1118
Telex: 7400905
Fax: 203-758-9518

To return a unit for repair, *if so authorized by GDC*, use the return tag and address the package:

Product Repair Department
General DataComm, Inc.
1579 Straits Turnpike
P.O. Box 1299
Middlebury, Connecticut 06762-1299

Lease and Maintenance contract customers may call DataComm Service Corporation toll-free at 1-800-243-1030, 24 hours a day, 7 days a week for trouble reporting or installation scheduling. (Installations are normally scheduled between 8 a.m. and 5 p.m.)

TRAINING

Hands-on training courses are available from DataComm Service Corporation's Educational Services in the USA and in the UK. Courses offered range from basic data communications, modems and multiplexers, to complex network systems, and are given at GDC's Connecticut facility or at a customer's location.

For information call:

USA (203) 574-1118, Ext. 6190.
UK 011-44-734-774-868

APPENDIX A

TECHNICAL INFORMATION

TECHNICAL CHARACTERISTICS

Item	Characteristic
Physical	
PC card assembly	
Height	1 1/2 in. (3.8 cm)
Width	10 1/2 in. (26.7 cm)
Depth	10 3/4 in. (27.3 cm)
Weight	1 lb. 12 oz. (0.8 kg)
Shipping weight	2 lb. 12 oz. (1.3 kg)
DataComm Enclosure (model DE-22)	
Height	3 7/8 in. (9.8 cm)
Width	10 7/8 in. (27.6 cm)
Depth	12 1/2 in. (31.8 cm)
Weight	7 lb. 1 oz. (3.2 kg)
Shipping weight	8 lb. 1 oz. (3.7 kg)
Four-slot DataComm FourPak Enclosure (model DFP-11)	
Height	5 1/4 in. (13.3 cm); 5 1/2 in. (14 cm) with rubber feet
Width	15 in. (38.1 cm)
Depth	13 1/2 in. (34.3 cm)
Weight	7 lb. 1 oz. (3.2 kg)
Shipping weight	8 lb. 1 oz. (3.7 kg)
Three-slot GDC TriPak Shelf (models TPS-1 and TPS-2)	
Height	3 1/2 in. (8.9 cm)
Width	19 in. (48.3 cm); 23 in. (58.4 cm) with adapter ears
Depth	12 in. (30.5 cm)
Weight	15 lb. 7 oz. (7 kg)
Shipping weight	20 lb. 7 oz. (9.3 kg)
Environmental	
Temperature	
Operating	32° to 122°F (0° to 50°C) (derate by 1°C/1000 ft above sea level)
Non-operating	
DataComm Enclosure (model DE-22)	-40° to 158°F (-40° to 70°C)
Rackmount, and other enclosures	-40° to 185°F (-40° to 85°C)
Humidity, operating	5% to 95%, without condensation
Altitude	
Operating	0 to 10,000 ft (0 to 3,048 m)
Non-operating	0 to 40,000 ft (0 to 12,192 m)

TECHNICAL INFORMATION

TECHNICAL CHARACTERISTICS (Cont.)

Item	Characteristic
Electrical	
Regulatory information	
UL 1459	This product meets the requirements of UL 1459
Power requirements	
Voltage	99 to 129 V ac
Frequency	60 Hz
Power dissipation	15 W maximum
Fusing (pc card)	Two 3.0 A FB, 250 V, 3AG (GDC Part No. 215-300-300)
	Four 1.5 A SB, 250 V, Axial-lead (GDC Part No. 215-202-004)
Data rates	Nx64 kbps or Nx56 kbps (N = 1 to 24); maximum aggregate
	(payload) rate of 1,536,000 bps
Communication line	T1 digital carrier (non-loaded, staggered-twist ABAM, PIC, or
	pulp-insulated exchange-type cable, 19 to 26 gauge)
Line impedance	100
Network port physical interface	RJ48C modular jack
Network transmitter	
Frequency	1,544,000 bps \pm 75 bps
Pulse amplitude	May vary over a cycle of 60 Hz current.
Without surge protection	2.70 to 3.30 V at 60°F
With surge protection	2.40 to 3.00 V at 60°F
Height variation with pulse pattern	2% (maximum)
Unbalance in height of adjacent negative and positive	200 mV (maximum)
pulses	
Width of output pulse (half amplitude)	324 nsec \pm 45 nsec
Unbalance in width of positive and negative pulses	20 nsec (maximum)
Time between two consecutive pulses of opposite polarity	648 nsec \pm 15 nsec
(measured at half amplitude point of leading edges)	
Maximum rise or falling time	100 nsec
Overshoot at trailing edge of pulse	10% to 30% of pulse amplitude
Line Build-Out	0, 7.5, or 15 dB (selectable or automatic) at 772 kHz
Output jitter	< 0.5 dB
Timing source	Internal clock, external clock (from channel), slave (received
	timing loopback)
Network receiver	
Operating range	0 to 30 dB of cable loss at 772 kHz
Input impedance	100
Jitter tolerance	Conforms to specifications defined in AT&T PUB 62411,
	December 1988
Longitudinal balance	35 dB from 50 to 1500 kHz
Electrical interface	Crystal Semiconductor CS61534/CS61574 PCM Line In-
	terface

TECHNICAL CHARACTERISTICS (Cont.)

Item	Characteristic
Electrical (Cont.)	
Channel port capacity	One
Channel port (customer equipment) interface	
Standard	One CCITT V.35-compatible synchronous serial data port
Optional	One EIA-530 compatible synchronous serial data port
Physical interface	
DataComm Enclosure model DE-22 with CCITT V.35 interface	CCITT V.35 (34-pin female connector)
DataComm Enclosure model DE-22 with EIA-530 interface, and all others	DB25S (25-pin female subminiature-D connector)
Supervisory port interface	
Physical interface	DB25P (25-pin male subminiature-D connector)
Interface standard	EIA/TIA-232-E, ANSI X3.64 ASCII-compatible
Baud rate	2400, 4800, 9600, and 19,200 bps
Character format	8/N/1, 7/N/1, 7/O/1, and 7/E/1 (word length/parity/stop bits)
Diagnostics	DS1 Line Loop, with Self-Test; DS1 Local Test with Self-Test; DS1 Network Interface Loopback, with Self-Test; DS1 Remote Test, with Self-Test; DS1 Self-Test; DS1 Test Loop, with Self-Test; DS0 Circuit Delay Measurement Test; DS0 Remote Test, with Self-Test; DS0 Self-Test; Channel Digital Loop; Channel Remote Digital Loop, with Self-Test; Channel Self-Test.
	Front panel test jacks for DS1 access
	WECO 551
CSU compatibility	
T1 compatibility	
Line code	AMI with no bipolar violations, and B8ZS
Clear Channel Capability	B8ZS
Network interface	1.544 Mbps channelized DS1 in consecutive or alternate DS0s (complies with AT&T 54019A specifications for FT1 transmission)
Consecutive zeros	15 or 39 maximum
Average pulse density	Minimum 1 "one" per 8 bits, or 24 "ones" per 192 bits
Keep Alive signal	Type 1 (consecutive, framed ones filling the unused bandwidth)
Framing format	D4 Superframe Format, AT&T 54016 Extended Superframe Format (ESF), and ANSI T1.403 ESF, with automatic conversion
Alarms and status conditions	Out of Frame (OOF), Alarm Indication Signal (AIS or Blue alarm), Loss of Signal (LOS), Red alarm, and Yellow alarm

APPENDIX B

TIMING OPTIONS

OVERVIEW

An understanding of the DataComm 552A-1 V1.1's timing options requires explanations that are more detailed than those normally provided. This appendix describes the details and applications of the DSU's timing options:

- Slave Timing
- Internal Timing
- Invert Channel Timing
- Channel Timing
- Channel Split Timing
- Internal/Channel Split Timing

Each description is accompanied by an illustration showing how the timing clock is distributed throughout the network and explaining how to set option switch S14A on the DSU-function card, as well as typical applications. Following the timing option descriptions are some representative network applications showing how to apply the timing options in a variety of network configurations.

TIMING OPTION DESCRIPTIONS

In synchronous T1 networks, all device transmitters and receivers are usually referenced to a single master timing source. This timing source, or clock, is frequently provided by the network and is highly accurate and stable. The DSU recovers the imbedded clock from the data stream and uses it to synchronize its own internal timing reference to the master clock. This allows it to reliably extract the data and to further distribute timing to other devices connected to it. (Timing is imbedded in the data stream on the network port, but is provided on separate channel interface leads.) When provided (as in a DACS-based system), the network's clock must be used. However, the DSU allows other timing options for use in applications where a network clock is not available.

TIMING OPTIONS

NOTE

Several techniques exist for providing timing to the customer equipment: smooth clock and variations of gapped clock. With a smooth or continuous clock, the type employed by the DSU, every clock pulse is the same length and occurs at the same interval. With a gapped clock, however, some pulses are intentionally omitted.

The default timing option for the DSU is Slave Timing and is used when the network provides the timing source. When the network does not provide the timing source, one DSU must use Internal Timing, Channel Timing (when customer equipment connected to it provides timing), or Internal/Channel Split Timing and the others usually use Slave Timing. When both the network and the customer equipment provide timing, you must use Channel Split Timing, a combination of Slave Timing and Channel Timing.

One thing is common to all of the DSU's timing options — The DSU recovers the clock from the network receive data, then uses it to clock data into the receive buffer and to provide the channel receive clock signal for the channel. What differs is the source of the master clock reference and the source of the channel transmit clock signal, as shown in Table B-1:

- With Slave Timing, the master clock comes from the network and the channel's transmit clock signal is derived from the clock recovered from the network receive data.
- With Internal Timing, the DSU provides the master clock, but the channel's transmit clock signal is still derived from the recovered clock.
- Invert Channel Timing, used with Slave Timing or Internal Timing to select the master clock, inverts the DSU's internal channel transmit clock signal.
- With Channel Timing, the customer channel equipment provides its own transmit clock signal, from which the DSU derives a master clock.
- With Channel Split Timing, the customer channel equipment provides its own transmit clock signal (like Channel Timing), but the network provides the master clock for the rest of the network (like Slave Timing).
- With Internal/Channel Split Timing, the DSU provides the master clock (like Internal Timing), but the customer channel equipment loops back the receive clock signal for use as its transmit clock signal (similar to Channel Split Timing).

TABLE B-1. TIMING OPTION REFERENCE

Timing Option	Master Clock Source			Ch. Transmit Clock Source	
	Network	DSU	Ch. Equipment	Network	Ch. Equipment
Channel Split Timing					
Channel Timing					
Internal Timing					
Internal/Channel Split Timing					
Invert Channel Timing, with Internal Timing					
Invert Channel Timing, with Slave Timing					
Slave Timing					

NOTE

All timing options that include split timing require each timing source to be traceable to a Stratum 1 clock.

On the network port, the data rate is 1.544 Mbps. On the channel port, however, the data rate may be from 56 kbps to 1.536 Mbps. The DSU compensates for this difference in data rates by translating the clock frequency when passing it from one port to another.

TIMING OPTIONS

Slave Timing

With Slave Timing, illustrated in Figure B-1, the network (or a device at the remote end) provides the timing source (1). The DSU recovers the receive T1 clock from the network receive T1 data and uses it to clock T1 data into the receive buffer (2) and to provide the send timing source for T1 data output from the transmit buffer (3) to the network. The DSU also translates (4) the receive T1 clock to provide the channel transmit and receive clock signals on the appropriate interface leads for the channel.

Select Slave Timing when using the DSU in a network (or with a device at the remote end) that supplies the clock, as in a DACS (Digital Access and Cross-connect System) network.

NOTE

- a. *Select the appropriate timing option for the customer equipment: The DSU provides transmit timing on the channel's Tx Clk lead.*
- b. *On loss of signal input from the network, the DSU defaults to Internal Timing.*

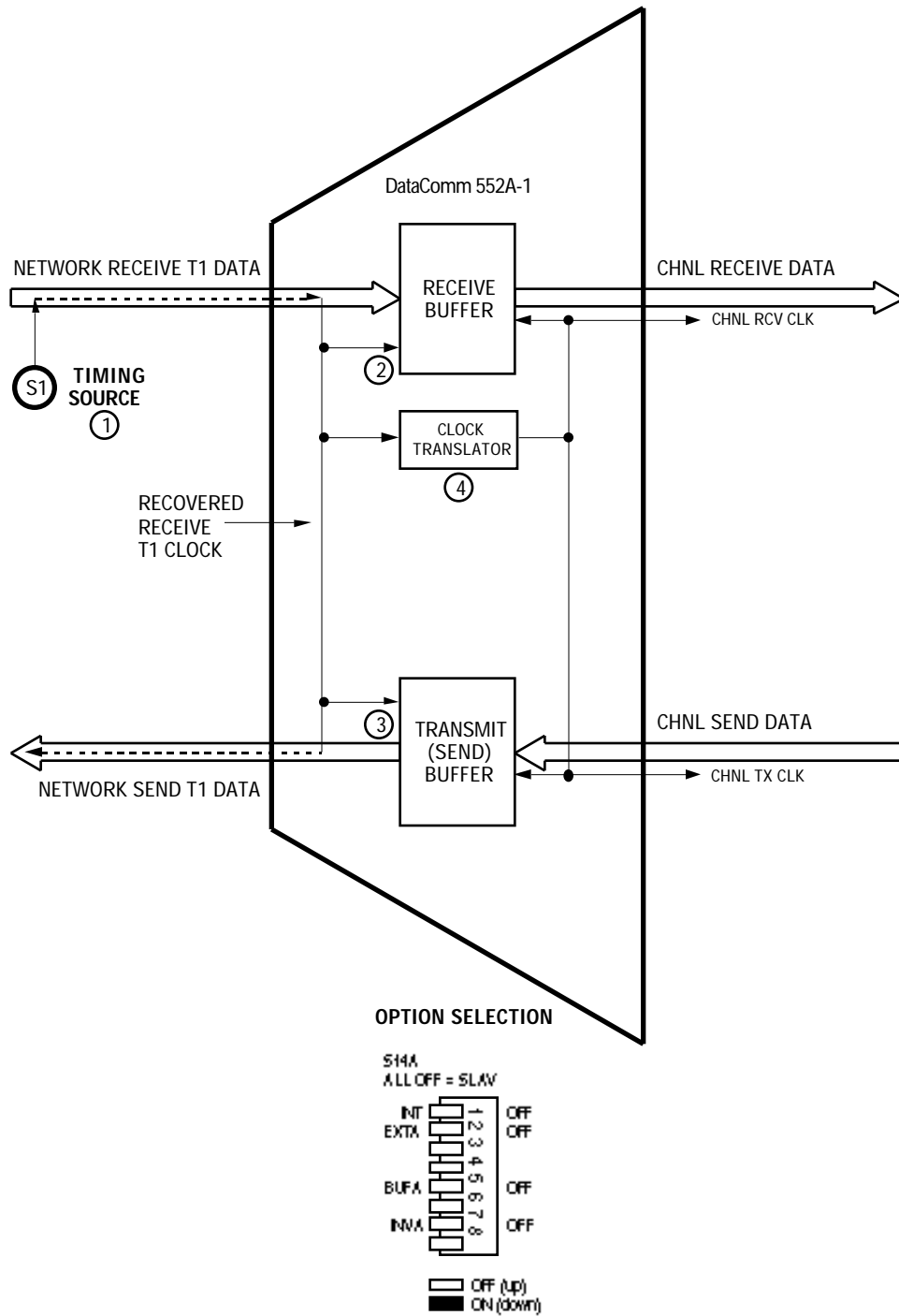

FIGURE B-1. SLAVE TIMING

TIMING OPTIONS

Internal Timing

With Internal Timing, illustrated in Figure B-2, the DSU provides the send timing source (1) for T1 data output from the transmit buffer (2) to the network. (This clock satisfies the requirements of a Stratum 4, Type II clock, as defined in PUB 62411.) The remote DSU uses this as its timing reference (3) and loops it back to the DSU (4). The DSU recovers the receive T1 clock from the network receive T1 data and uses it to clock T1 data into the receive buffer (5). The DSU also translates (6) the receive T1 clock to provide the channel transmit and receive clock signals on the appropriate interface leads for the channel.

Select Internal Timing when using the DSU in a private network that does not provide timing (e.g., a non-DACS based service).

NOTE

- a. *Configure only one DSU in your network for Internal Timing, and configure the others for Slave Timing.*
- b. *Select the appropriate timing option for the customer equipment: The DSU provides transmit timing on the channel's Tx Clk lead.*

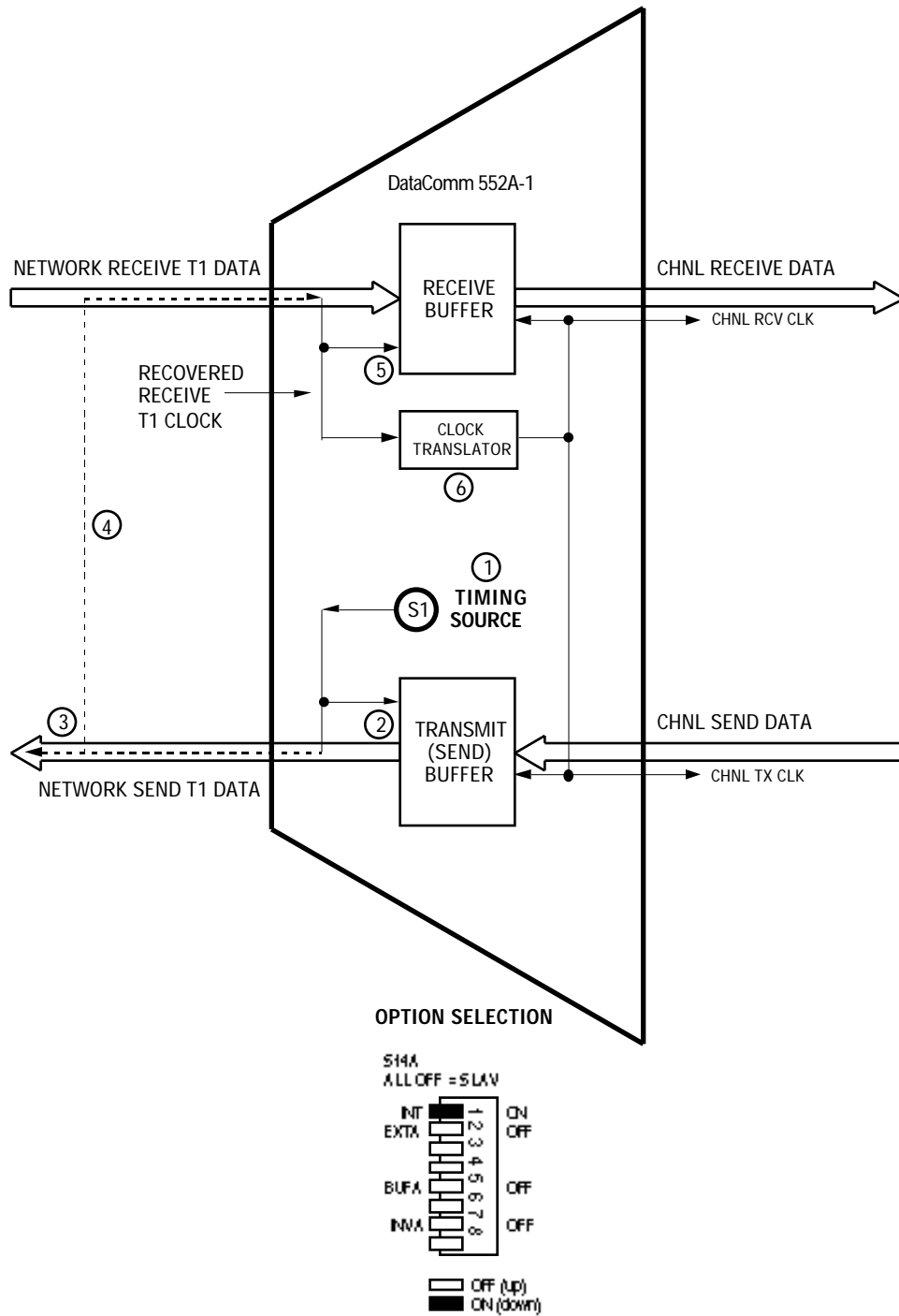

FIGURE B-2. INTERNAL TIMING

TIMING OPTIONS

Invert Channel Timing

Invert Channel Timing is used with either Slave Timing or Internal Timing. The master clock is determined by the Slave Timing or Internal Timing option, and Invert Channel Timing, illustrated in Figure B-3, inverts (1) the DSU's internal channel transmit clock signal.

Select Invert Channel Timing, with either Slave Timing or Internal Timing, in a high channel data rate application when there are data errors and you suspect they are caused by a delay between the DSU's clock and data arriving from the DTE.

NOTE

- a. *Select the appropriate timing option for the customer equipment: The DSU provides transmit timing on the channel's Tx Clk lead.*
- b. *This option is available only on units which have beside S14A either a label with the new switch names or the names printed on the pc card.*

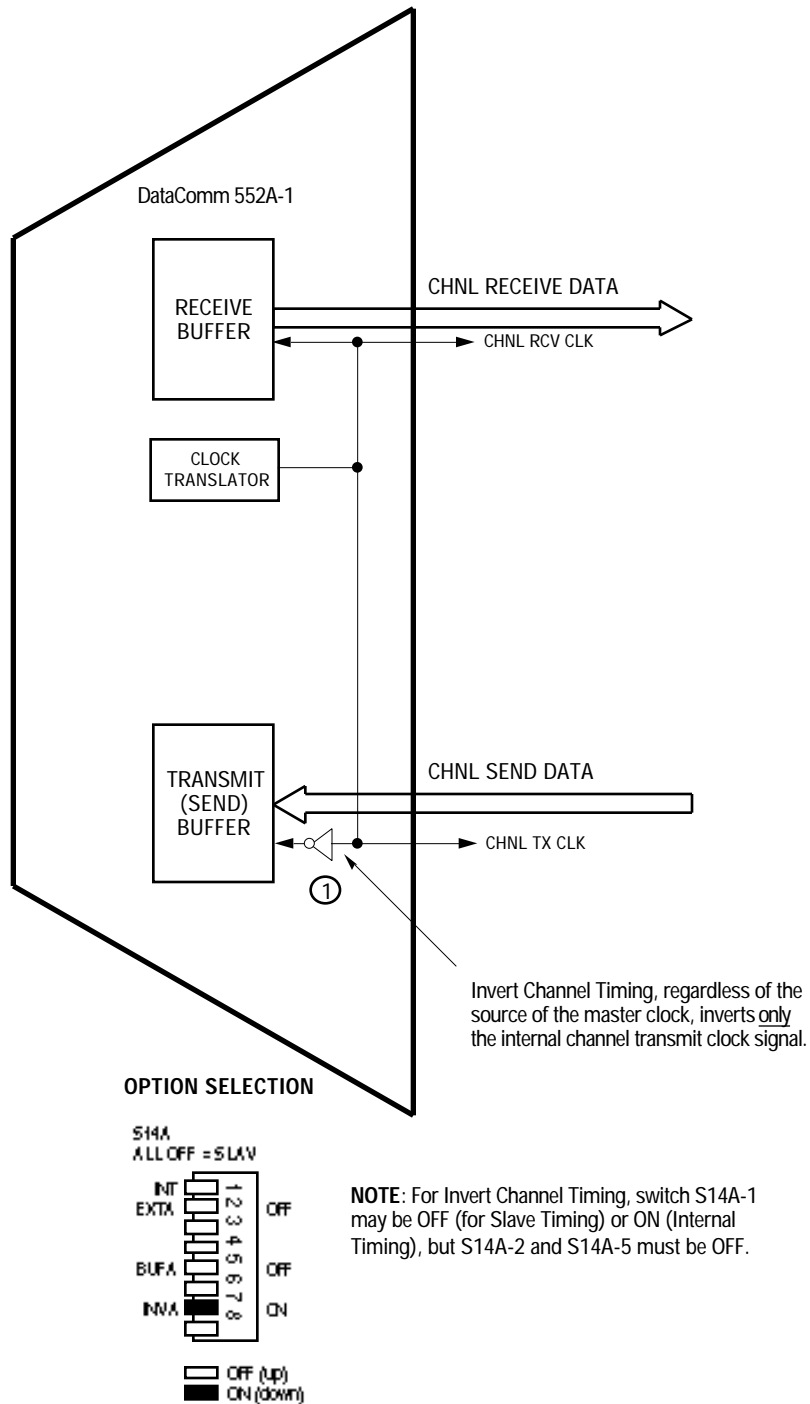

FIGURE B-3. INVERT CHANNEL TIMING

TIMING OPTIONS

Channel Timing

With Channel Timing, illustrated in Figure B-4, the customer channel equipment provides its own channel transmit clock signal (1) on the appropriate interface lead. The DSU translates (2) this clock to provide the send timing source for T1 data output from the transmit buffer (3) to the network. The remote DSU uses this as its timing reference (4) and loops it back to the DSU (5). The DSU recovers the receive T1 clock from the network receive T1 data and uses it to clock T1 data into the receive buffer (6). The DSU also translates (7) the receive T1 clock to provide the receive clock signal for the channel, on the appropriate interface lead.

Select Channel Timing when using the DSU in a private network with the customer channel equipment supplying the clock.

NOTE

- a. *Select the appropriate timing option for the customer equipment: The DSU expects external timing on the channel's Ext Clk lead.*
- b. *If the channel equipment clock source fails, the network also will fail, as the DSU has no other timing source.*

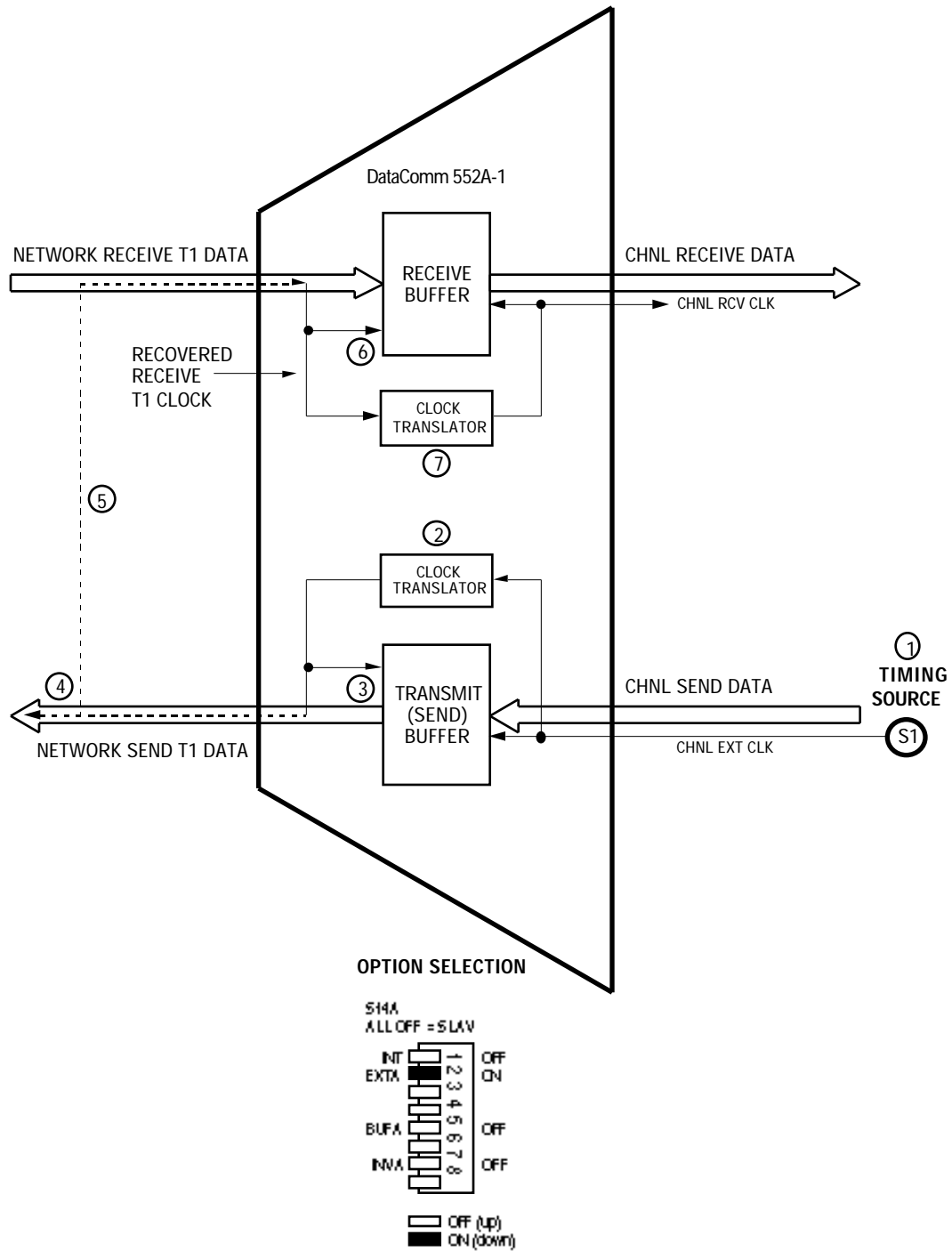

FIGURE B-4. CHANNEL TIMING

TIMING OPTIONS

Channel Split Timing

Channel Split Timing, illustrated in Figure B-5, is a combination of Slave Timing and Channel Timing, and it utilizes two clock sources. As in Slave Timing, the network (or a device at the remote end) provides one timing source (1). The DSU recovers the receive T1 clock from the network receive T1 data and uses it to clock T1 data into the receive buffer (2) and to provide the send timing source for T1 data output from the transmit buffer (3) to the network. The DSU also translates (4) the receive T1 clock to provide the receive clock signal for the channel, on the appropriate interface lead. As in Channel Timing, the customer channel equipment provides the other timing source, its own channel transmit clock signal (5) on the appropriate interface lead, but the DSU uses it for nothing else.

Select Channel Split Timing when there are timing sources provided by both the network and the customer equipment.

NOTE

- a. *Select the appropriate timing option for the customer equipment: The DSU expects external timing on the channel's Ext Clk lead.*
- b. *All timing options that include split timing require each timing source to be traceable to a Stratum 1 clock.*
- c. *On loss of signal input from the network, the DSU defaults to Internal Timing. However, since the DSU's clock is a Stratum 4 clock, the system will fail due to transmit buffer crash.*

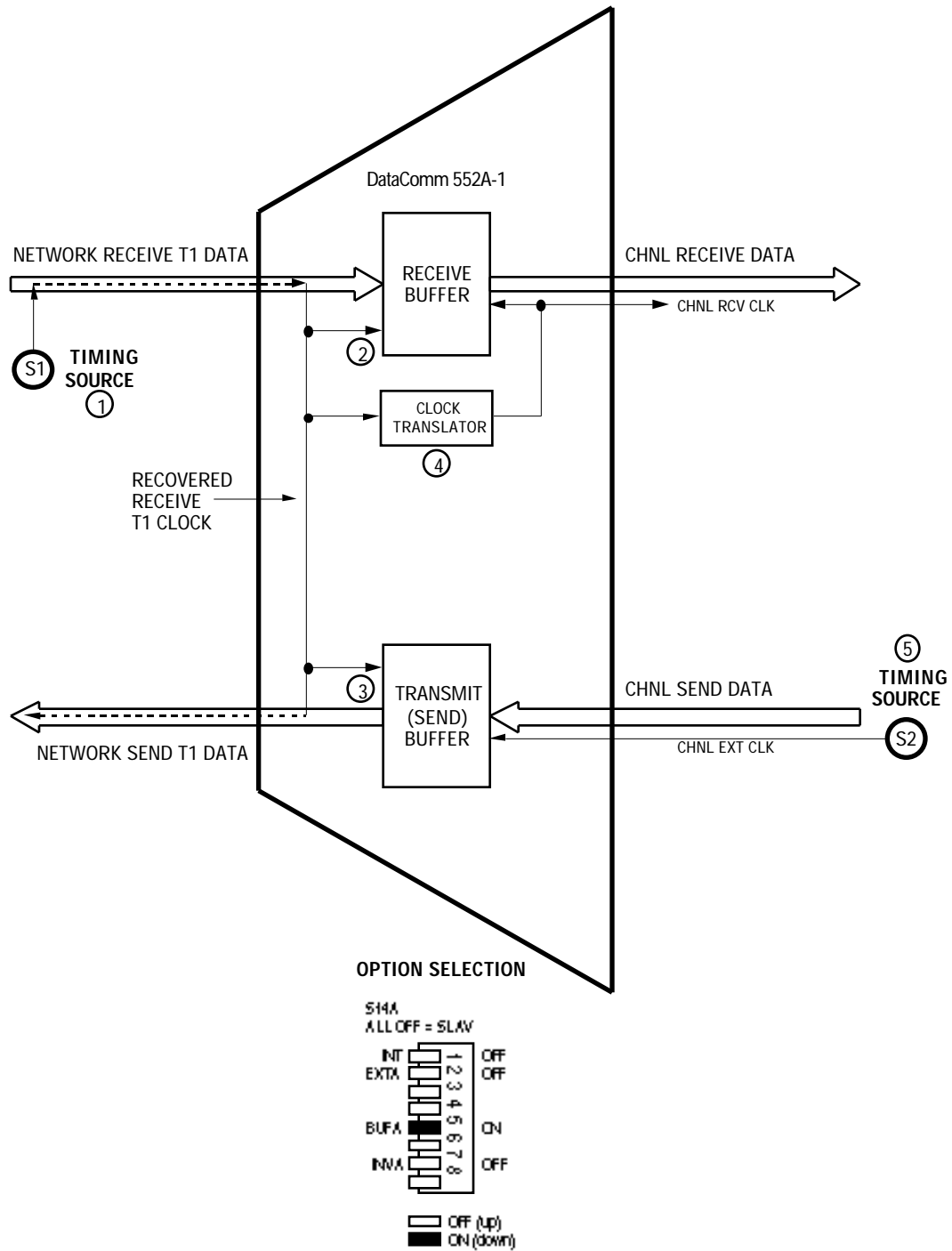

FIGURE B-5. CHANNEL SPLIT TIMING

TIMING OPTIONS

Internal/Channel Split Timing

With Internal/Channel Split Timing, illustrated in Figure B-6, the DSU provides the send timing source (1) for T1 data output from the transmit buffer (2) to the network. (This clock satisfies the requirements of a Stratum 4, Type II clock, as defined in PUB 62411.) The remote DSU uses this as its timing reference (3) and loops it back to the DSU (4). The DSU recovers the receive T1 clock from the network receive T1 data and uses it to clock T1 data into the receive buffer (5). The DSU also translates (6) the receive T1 clock to create the receive clock signal for the channel, on the appropriate interface lead. The customer equipment on the channel (or a device on the channel) must loop the receive clock signal back to the DSU on the Chnl Ext Clk lead (7).

NOTE

The timing signal applied to the Chnl Ext Clk lead of the DSU configured with the Internal/Channel Split Timing option must be traceable to the timing source, S1: If customer equipment is connected to the channel, it must loop timing from the Chnl Rcv Clk lead to the Chnl Ext Clk lead. If a DSU is connected to the channel (i.e., back-to-back channels), it must be configured for Channel Timing and other DSUs are usually configured for Slave Timing.

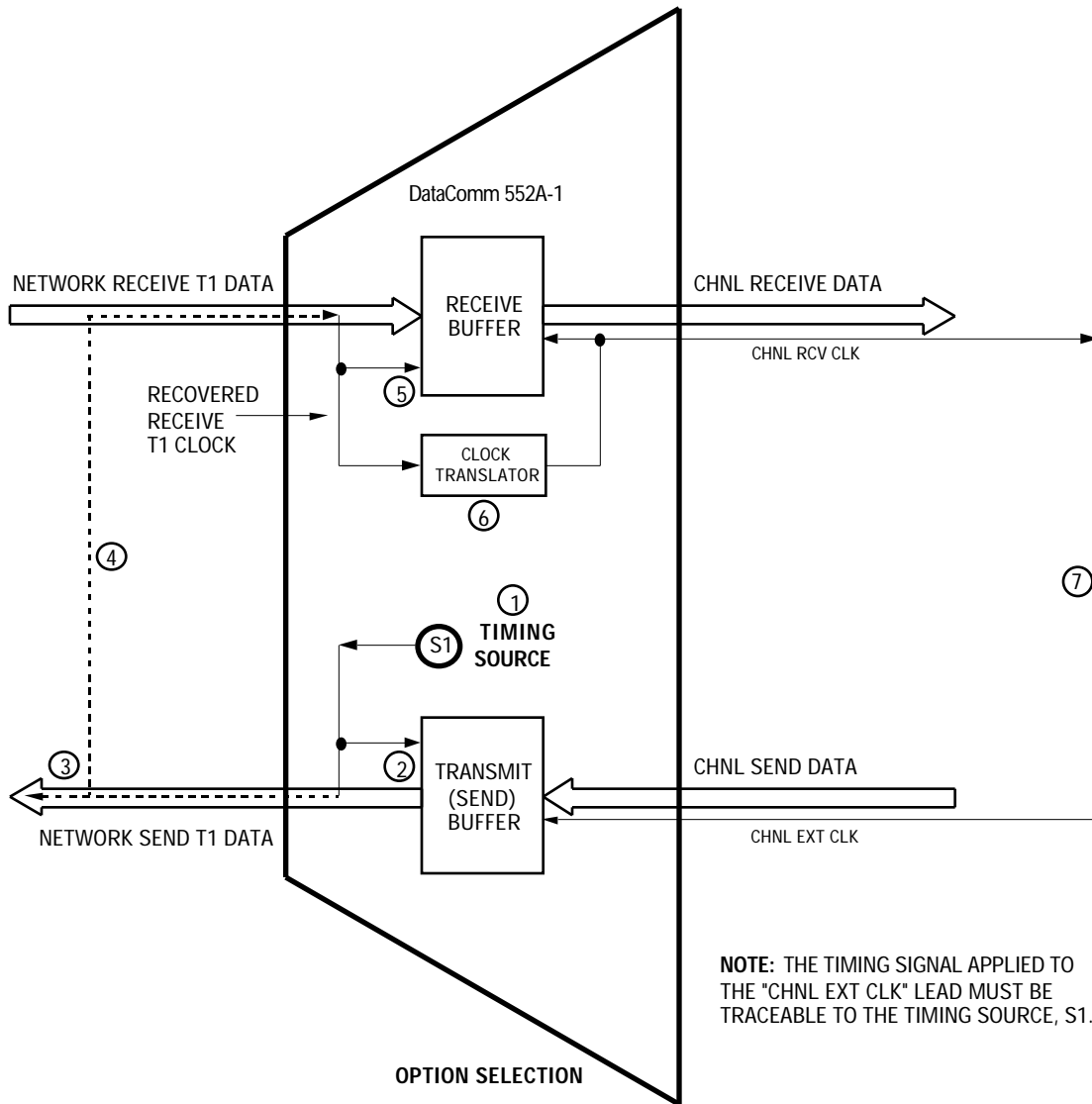

OPTION SELECTION

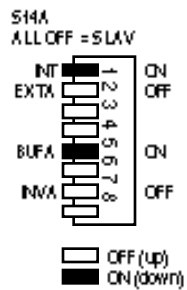

FIGURE B-6. INTERNAL/CHANNEL SPLIT TIMING

TIMING OPTIONS

TYPICAL NETWORK APPLICATIONS

Back-to-Back DSU Application

Although you can use the DSU in various network configurations with different types of equipment, the following simple applications illustrate the fundamental reasoning you use to select the appropriate timing option.

In an in-house data communications network, two DSUs are connected back-to-back. The only component connecting them is cable, so there is no network to provide the timing source.

If the customer channel equipment cannot provide timing, select Internal Timing for the master or host end, and select Slave Timing for the other, as shown in Figure B-7A. In this example, the DSU at Site A is configured for Internal Timing, making it the timing source.

If the customer equipment is to provide an external timing source, select Channel Timing for the DSU connected to that equipment and select Slave Timing for the other, as shown in Figure B-7B. In this example, the host computer on the channel at Site A is providing timing, so its DSU is configured for Channel Timing.

In the master/slave multiplexer application illustrated in Figure B-7C, the multiplexer on the channel at Site A is configured as the master (i.e., the timing source) and the multiplexer on the channel at Site B is configured as a slave. By selecting Channel Timing for both DSUs, the master multiplexer provides timing and the slave multiplexer loops back timing, so timing is dependent on the customer equipment.

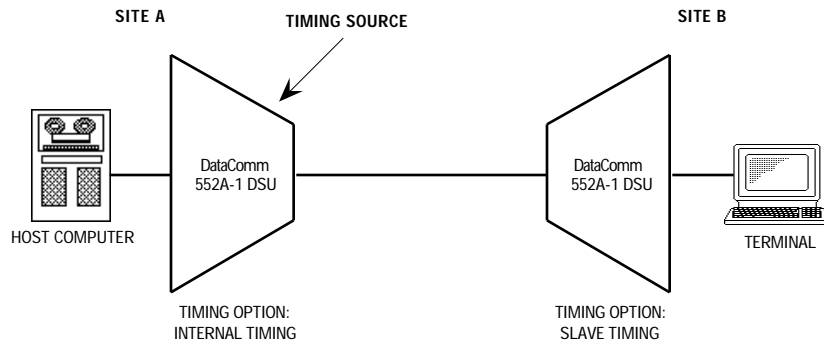

A. DSU AT SITE A SUPPLIES TIMING

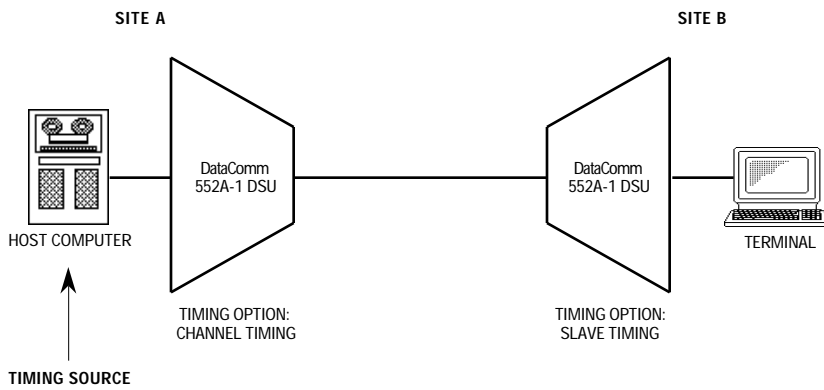

B. CUSTOMER EQUIPMENT AT SITE A SUPPLIES TIMING

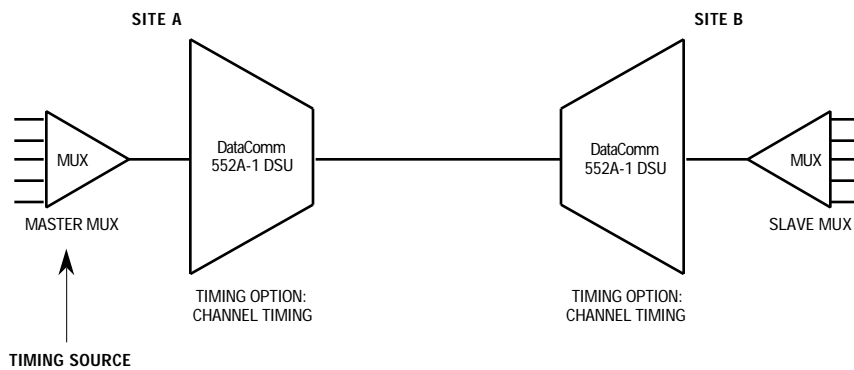

C. MASTER/SLAVE MULTIPLEXER TIMING

FIGURE B-7. TYPICAL BACK-TO-BACK DSU APPLICATIONS

TIMING OPTIONS

Back-to-Back Channel Application

For an application requiring channels connected back-to-back, as illustrated in Figure B-8, the DSU labeled DSU #B-1 at Site B is configured for Internal/Channel Split Timing and it provides timing for the network. The 552A at Site A (as well as the one at Site C) is configured for Slave Timing and it loops back the clock signal, which then passes through DSU #B-1 to DSU #B-2. DSU #B-2 is configured for Channel Timing: It passes the clock signal on to the DSU at Site C, which loops back the clock signal, then sends it to DSU #B-1, completing the path.

NOTE

The timing signal applied to the Chnl Ext Clk lead of the DSU configured with the Internal/Channel Split Timing option must be traceable to the timing source, S1: If customer equipment is connected to the channel, it must loop timing from the Chnl Rcv Clk lead to the Chnl Ext Clk lead. If a DSU is connected to the channel (i.e., back-to-back channels), it must be configured for Channel Timing and other DSUs are usually configured for Slave Timing.

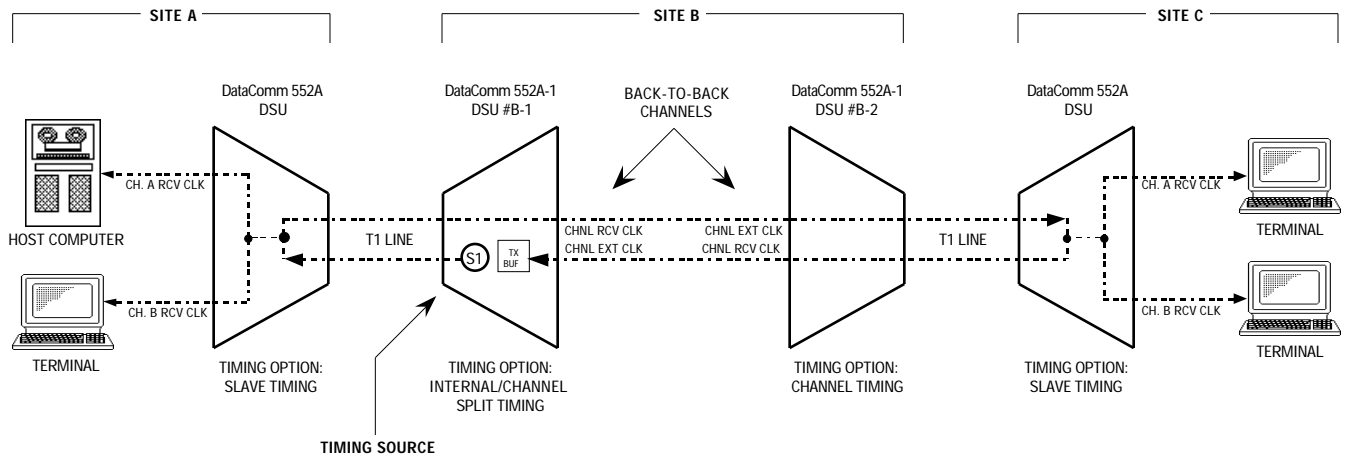

FIGURE B-8. TYPICAL BACK-TO-BACK CHANNEL APPLICATION

TIMING OPTIONS

DACS Application

In a typical public data network application utilizing the Fractional T1 capabilities of the DSU, the network uses DACS for DS0 routing, as illustrated in Figure B-9. Because of its distributed nature and its interconnection to many devices, the public data network must be the master timing source. You normally select Slave Timing for all DSUs connected directly to DACS (Sites A, B, and C in this example), but this example also shows a DDS (Dataphone Digital Service) network between Sites C and D. Since DDS is part of the public data network, it too must be considered a master timing source. Having multiple timing sources with accuracies that are close, but not equal, can cause bit slips and other events which result in data errors or system failures. By selecting Channel Split Timing for the DSU at Site C, the DDS clock and the DACS clock are effectively isolated: the network side of the DSU terminates the DACS clock, and the channel side terminates the DDS clock.

NOTE

All timing options that include split timing require each timing source to be traceable to a Stratum 1 clock.

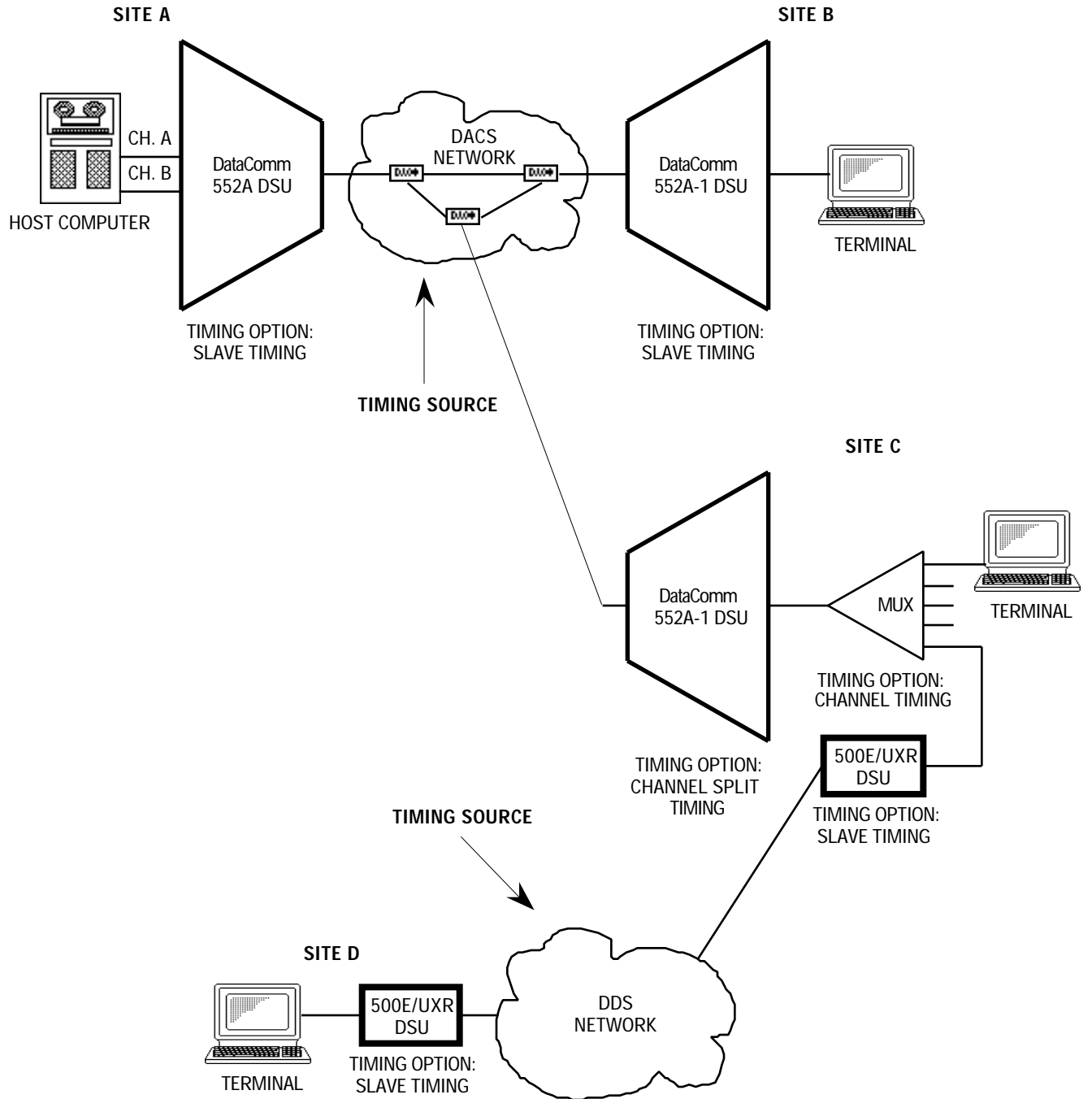

FIGURE B-9. TYPICAL DACS APPLICATION

TIMING OPTIONS

High Channel Data Rate Application

The length of the cable connecting the customer equipment (the DTE) to the DSU is an important factor when using DCE timing in a high channel data rate application. (With DCE timing, the DSU provides timing to the DTE. The DCE timing options in the DSU include Slave Timing and Internal Timing.) The cable creates a delay between the DSU's clock and data arriving from the DTE. When this delay is too great (because the cable is too long or the rate too high), it can cause errors.

If errors occur with DCE timing, you can use Channel Split Timing for the DSU and loop timing for the DTE, as illustrated in Figure B-10. This permits operation at any data rate, regardless of cable length. (Note that the CCITT V.35 recommendation limits cable length to about 30 m.)

NOTE

Select the appropriate timing option for the DTE: The DTE must loop timing from the Chnl Rcv Clk lead to the Chnl Ext Clk lead.

Alternatively, you can use Invert Channel Timing for the DSU and DCE timing for the DTE.

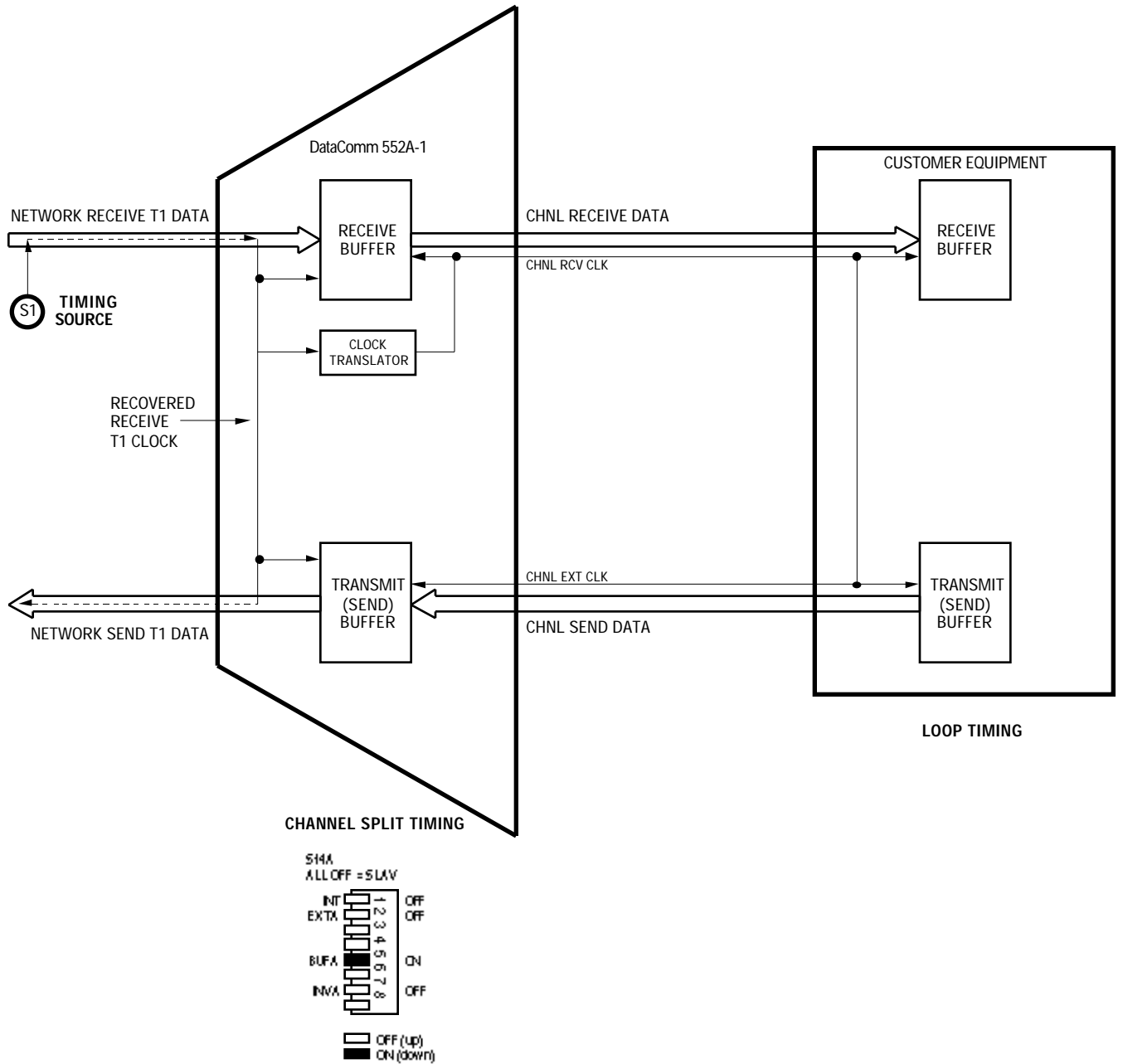

FIGURE B-10. CHANNEL SPLIT TIMING, WITH DTE LOOP TIMING

APPENDIX C

CONFIGURATION CROSS-REFERENCE

OVERVIEW

You can configure some of the DataComm 552A-1 V1.1's options via option switches or jumpers (hard configuration), some via the Supervisory terminal (soft configuration), and some via either method. This appendix provides a complete cross-reference of the DSU's hard- and soft-configurable options. The options are arranged alphabetically, by type (channel options, network options, etc.). Each option includes the default selection and the option switch (or jumper) or Supervisory function (the option name and screen name where you can find it) that controls the option.

This appendix does not include information about an option's other selections or conditions applicable to it. You can find that information either in Section 2 (hard configuration) or Section 3 (soft configuration).

The cross-reference begins on the following page.

NOTE

Option switches S3 through S6, and jumpers X1 and X5, are on the CSU-function card. Switches S10 through S16 are on the DSU-function card.

CONFIGURATION CROSS-REFERENCE

Category and Option Name	Default Selection	Configuration Mode	
		Hard (Switch Number)	Soft (Screen Title/Option Name)
Channel Options			
Alternate DS0	Consecutive	S10-7	CHANNEL CONFIGURATION (Alternate DS0)
Channel Data Rate	56 kbps	S15-1 — S15-5	CHANNEL CONFIGURATION (Enter Channel Rate)
Channel Digital Loop Timer	Inhibit	n/a	CHANNEL CONFIGURATION (Inband DL Timeout)
Channel RDL Response	Enabled	S10-8	CHANNEL CONFIGURATION (Respond to RDL)
CMI Signalling	Off	S12-7	CHANNEL CONFIGURATION (Control Mode Idle Option)
CTS Operation	10 ms delay	S12-8	CHANNEL CONFIGURATION (RTS-to-CTS Option)
Digital Loop Enable	Disabled	S12-4	n/a
DS0 Starting Number	DS0 1	S15-7 — S16-3	CHANNEL CONFIGURATION (Starting DS0 Number)
DS0 Type	Nx56 kbps	S15-6	CHANNEL CONFIGURATION (Enter Channel Rate)
DSR Operation	Forced ON	S12-6	n/a
Local Loop Enable	Disabled	S12-5	n/a
Remote Digital Loop Enable	Disabled	S12-2	n/a
Remote Digital Loop Pattern	PN-127	S12-1	CHANNEL CONFIGURATION (RDL Inband Code)
Test Mode Status	Disabled	S12-3	n/a
Network Options			
AIS Loop-Down	Inhibit	n/a	CSU CONFIGURATION (AIS Loopdown)
Auto Framing	Disabled	S3-3	CSU CONFIGURATION (Network Frame)
Line Code	AMI	S3-5	CSU CONFIGURATION (Network Code)
Loop Span Power	Enabled	X5 (CSU)	n/a
Network Compatibility	ANSI mode	S6-8	CSU CONFIGURATION (ESF Mode)
Network Frame Format	ESF framing	S3-1	CSU CONFIGURATION (Network Frame)
Network Line Build-Out	Manual	S6-4	CSU CONFIGURATION (Line Build-Out)
Network Line Build-Out Amount	0 dB	S6-5, S6-6	CSU CONFIGURATION (Line Build-Out)
Ones Density	15 zeros	S3-8	CSU CONFIGURATION (Ones Density)

CONFIGURATION CROSS-REFERENCE

Category and Option Name	Default Selection	Configuration Mode	
		Hard (Switch Number)	Soft (Screen Title/Option Name)
Supervisory Options			
Soft Configuration Privileges	Full Control (master DSU)	S4-6	n/a
Supervisory Port Baud Rate	9600 bps	S4-1, S4-2	n/a
Supervisory Port Character Format	8 data bits/no parity/1 stop bit	S4-4, S4-5	n/a
System Options			
Configuration Mode	Soft	S6-7	n/a
DSU Address Number	Address 000	S5-1 — S5-8	n/a
Front Panel Switches	Enabled	S4-7	n/a
Ground	Open	X1 (CSU)	n/a
PMC-100 Operation	Disabled	S4-3	n/a
Set System Date	Firmware release	n/a	MAINTENANCE (Set Date)
Set System Time	00:00	n/a	MAINTENANCE (Set Time)
Test Options			
DS0 Channel to Test	Channel 24	n/a	DS0 DIAGNOSTICS (DS0 Channel Number)
DS0 Test Pattern	511-bit	n/a	DS0 DIAGNOSTICS (Select Test Pattern)
DS1 Self-Test Pattern	QRS	n/a	CSU SELF TEST (Select Test Pattern)
In-Band DS1 Loopback Code Detection	Enabled	S4-8	CSU CONFIGURATION (Inband Loop)
In-Band DS1 Loopback Code Framing	Framed	S3-7	CSU CONFIGURATION (ILB Frame)
In-Band DS1 Loopback Code Test Type	DS1 Line Loop	S3-6	CSU CONFIGURATION (Test Type)
Timing Options			
Channel Timing	Disabled	S14A-2	n/a
Channel Split Timing	Disabled	S14A-5	n/a
Internal Timing	Disabled	S14A-1	n/a
Invert Channel Timing	Disabled	S14A-7	n/a

APPENDIX D

GLOSSARY

Accunet	Data-oriented digital services from AT&T Communications, including Accunet T1.5, terrestrial wide-band at 1.544 Mbps (formerly called T1); Accunet Reserved T1.5, satellite-based channels at 1.544 Mbps primarily for video teleconferencing applications; Accunet Packet Services, packet-switching services; Accunet Data-phone digital service (DDS), private-line digital circuits at 2.4, 4.8, 9.6, and 56 kbps.
Address	A sequence of bits, a character, or a group of characters that identifies a network station, user, or application; used mainly for routing purposes.
Alarm Indication Signal (AIS)	An AIS is a keep alive signal of continuous, framed "ones" filling the unused bandwidth, and is required by the network in the absence of a normal DS1 signal. In response to receiving an AIS, LOS, or OOF from one side, the DSU returns a Yellow alarm, and transmits an AIS to the other side. An AIS is transmitted until the error condition clears. An AIS is also called a Blue alarm.
Analog	Transmission employing variable and continuous waveforms to represent information values.
Anti-Streaming Timer	Ability in a modem to ignore a Request to Send (RTS) signal from a data terminal if it is held on for longer than a specified amount of time.
Asynchronous	Transmission that is not related to a specific frequency or to the timing of the transmission facility; transmission characterized by individual characters or bytes with start and stop bits from which a receiver derives the necessary timing for sampling bits; start-stop transmission.
Asynchronous Transmission	Serial transmission of data in which each character is individually synchronized by the use of start and stop bits. A start bit precedes and one or more stop bits follow continuous information bits. Also called start-stop transmission. There is no definite time relationship between transmission of successive characters.
Baud	The maximum number of signalling elements, or symbols, per second that are generated; may be different from bps rate as several bits may be encoded per symbol, or baud, with advanced encoding techniques such as phase-shift keying.
BER	Bit Error Rate.
BERT	Bit Error Rate Test, or tester.
Bipolar	The predominant signalling method used for digital transmission services, such as DDS and T1, in which the signal carrying the binary value successively alternates between positive and negative polarities. Zero and one values are represented by the signal amplitude at either polarity, while no-value "spaces" are at zero amplitude; also, polar transmission.
Bit	A binary digit, the representation of a signal, wave, or state, as either a binary zero or a one.

GLOSSARY

Bit Error Rate (BER)	The percentage of received bits that are in error, relative to a specific amount of bits received; usually expressed as a number referenced to a power of 10; e.g., 1 in 10^5 .
Blue Alarm Signal	See Alarm Indication Signal.
BOC	Bell Operating Company; one of 22 local telephone companies spun off from AT&T as a result of divestiture.
Bps	Bits per second; basic unit of measure for serial data transmission capacity; also kbps (kilobits), for thousands of bits per second; Mbps (megabits), for millions of bits per second; Gbps (gigabits), for billions of bits per second; Tbps (terabits), for trillions of bits per second.
Byte	Generally an 8-bit quantity of information, used mainly in referring to parallel data transfer, memory capacity, and data storage; also generally referred to in data communications as an octet or character.
Card	A card is an assembly of components that can be tested, removed, and replaced as a unit. A card usually refers to a single unit without piggybacks connected to it. Also called pc board.
Channel	Part of a circuit path through several entities in a communication system. A channel runs between two nodes.
Channel Service Unit (CSU)	A component of customer premises equipment (CPE) used to terminate a digital circuit, such as DDS or T1, at the customer site; performs certain line-conditioning features, ensures network compliance per FCC rules, and responds to loop-back commands from central office; also, ensures proper ones density in transmitted bit stream and performs bipolar violation correction.
Character	Standard bit presentation of a symbol, letter, number, or punctuation mark.
Clock	An oscillator-generated signal that provides a timing reference for a transmission link; used to control the timing of functions as sample interval, signalling rate, and duration of signal elements; an "enclosed" digital network typically has only one "master" clock.
Common Carrier	In the United States, any supplier of transmission facilities or services to the general public that is authorized to provide such facilities or services by the appropriate regulatory authority and bound to adhere to the applicable operating rules, such as making services available at a common price and on a nondiscriminatory basis.
Contention	Competition among customer channels, on a first in/first out basis, for the right to use a transmission channel, whether a PBX circuit, a computer port, or a time slot, within a multiplexed digital facility.
Control Characters	Any transmitted characters, not message or user data, used to control or facilitate data transmission between data terminal equipment (DTE); includes extra characters associated with addressing, polling, message delimiting and blocking, framing, synchronization, and error checking.
Controlled Slip Event	A controlled slip event is the occurrence of a replication or deletion of one DS1 frame by the receiving equipment, and is counted as one event. A controlled slip event occurs when the difference in the timing between the synchronous receiving equipment and the received signal is of such magnitude that it exhausts the buffer capability of the equipment.

CRC	Cyclic Redundancy Check.
CRC-6 Error Event	A CRC-6 error event occurs when the CRC code calculated at the receiving end does not match the CRC code calculated by the transmitting end. The CRC is a method of detecting errors in the DS1 signal, and is performed on each ESF superframe.
CSU	Channel Service Unit.
Cyclic Redundancy Check	A characteristic link-level feature of (typically) bit-oriented data communications protocols, wherein data integrity of a received frame or packet is checked using a polynomial algorithm based on the content of the frame, and then matched with the result performed by the sender and included in a (typically 16-bit) field appended to the frame; basic error-checking mechanism for link-level data transmissions.
D4	An AT&T specified frame format that designates every 193rd bit position in an AT&T supplied T1 facility reserved for D4, which allows continuous monitoring and nondestructive diagnostic framing to be implemented by the carrier.
D4 Framing Format	D4 is a digital signal framing format combining 12 frames of 193 bits each into a superframe, and designating every 193rd bit position as reserved for framing and synchronization.
Data	Digitally represented information, which includes voice, text, facsimile, and video.
Data Commonality	General DataComm's term to describe a unique packaging technique that provides (1) high density modular packaging, (2) a broad array of versatile data sets and accessories, (3) system flexibility and ease of expansion, (4) low power consumption, (5) heat dissipation, (6) quick and simple installation, (7) at-a-glance monitoring of system operation, (8) convenient, low-cost maintenance, and (9) high reliability.
Data Communications	Transmitting and receiving coded digital signals between computers or other digital devices or systems according to agreed upon specifications or standards.
Data Communications Equipment (DCE)	Equipment that provides the signal conversion, connection control, and coding required for communication between data terminal equipment and data circuits; may be independent (e.g., a modem) or an integral part of a computer.
Data Frame	A repeating sequence in which channel data is multiplexed into an aggregate data stream.
Data Link	Any serial data communications transmission path, generally between two adjacent nodes or devices with no intermediate switching nodes.
Data Terminal Equipment (DTE)	Generally end-user devices, such as terminals and computers that connect to DCE, which generate or receive the data carried by the network; in RS-232-C and EIA/TIA-232-E connections, designation as DTE or DCE determines signalling role in handshaking.
dB	Decibel; a unit of measurement used to express the ratio of two values, usually the power of electrical or electromagnetic signals; equal to 10 times the logarithm derived from a ratio of the two power levels, which are expressed in watts; the relative gain or loss of a signal when the measured signal value is compared in a ratio to another, usually its input, value.

GLOSSARY

DCE	Data Communications Equipment. A term usually meant to refer to the modem portion of a data communications network. Also, data circuit-terminating equipment. In the case of an EIA/TIA-232-E (RS-232-C) connection, the modem is the DCE; in a CCITT X.25 connection, the network access and packet-switching node is the DCE.
DDS	Dataphone digital service; private-line digital service offered intra-LATA by BOCs, inter-LATA by AT&T Communications, with data rates typically at 2.4, 4.8, 9.6, and 56 kbps; now a part of the services listed by AT&T under the Accunet family of offerings.
Dial-up	The process of, or the equipment or facilities involved in, establishing a temporary connection via the switched telephone network.
Digital	Techniques and equipment in which information is encoded as either a binary "1" or "0"; the representation of information in discrete binary form, discontinuous in time, as opposed to the analog representation of information in variable, but continuous waveforms.
Digital Terminating Equipment (DTE)	Terminal equipment on the customer's premises. DTE includes the DSU functionality which may or may not be physically incorporated into the same equipment package as other DTE functions at the manufacturers' or customers' option.
Digital Signal Level 0 (DS0)	DS0 designates a 64 kbps digital signal, a channel, comprised of 8,000 8-bit bytes of customer data.
Digital Signal Level 1 (DS1)	DS1 designates the combination of 24 DS0 channels plus overhead bits into a 1.544 Mbps T1 data stream. A DS1 signal is one that conforms to DS1 specifications.
DTE	Data Terminal Equipment.
EIA	Electronic Industries Association.
EIA/TIA-232-E	An EIA-specified physical interface, with associated electrical signalling, between data circuit-terminating equipment (DCE) and data terminal equipment (DTE); the most commonly employed interface between computers and modems.
EPROM	Erasable programmable read-only memory.
Equalization	The process of reducing the effect(s) of amplitude frequency and/or phase distortion of a circuit by the introduction of networks to compensate for the difference in attenuation and/or time delay at the various frequencies in the transmission bands.
Equipment	The customer-provided multiplexer (and its attachments) connected to the DSU.
Error Free Second (EFS)	An EFS is a second in which no error event has been detected.
Errored Second (ES)	An ES is a second with one or more ESF error events.
ESF Error Event	An Extended Superframe Format (ESF) error event is an ESF frame that contains a CRC-6 error event or an OOF state, or both. ESF error events are processed to derive ESs and SESSs.

Excessive Bipolar Violation Condition

An excessive bipolar violation condition occurs when more than 1,544 bipolar violations (BPVs) occur in 1,000 consecutive seconds. The condition clears when no BPVs occur for 85 consecutive seconds. A BPV is the occurrence of two or more consecutive bits in the DS1 signal that do not alternate between signal levels as required by the network for Alternate Mark Inversion (AMI) data encoding.

Extended Superframe Format (ESF)

ESF is an extension of the D4 framing format, combining 24 frames of 193 bits each into an extended superframe, and providing improved performance monitoring capabilities and protection against false framing.

Facsimile

The communications process in which graphics or text documents are scanned, transmitted via a (typically dial-up) phone line, and reconstructed by a receiver; facsimile device operation typically follows one of the CCITT standards for information representation and transmission (Group 1 analog, with page transmission in four or six minutes; Group 2, with page transmission in two or three minutes, and Group 3 digital, with page transmission in less than one minute); also Fax.

511-Bit Test Pattern

An irregular, quasi-random pattern of 511 bits used to test and measure network jitter.

Frame

A group of bits sent serially over a communications channel; generally a logical transmission unit sent between data-link-layer entities that contains its own control information for addressing and error checking; the basic data transmission unit employed with bit-oriented protocols similar to blocks.

Frame Synchronization Bit Error Event

This is the occurrence of a bit error within the framing-pattern-sequence of an ESF superframe.

Fusible Link

Thin printed circuit fuses on pc boards that open if ground potential exceeds 0.25 V rms between pc board and peripheral equipment.

Ground

An electrical connection or common conductor that, at some point, connects to the earth.

Handshake Protocol

In communications, a predefined exchange of signals or control characters between two devices or nodes that sets up the conditions for data transfer or transmission; also, handshaking.

Interface

A shared boundary; a physical point of demarcation between two devices, where the electrical signals, connectors, timing, and handshaking are defined; the procedure, codes, and protocols that enable two entities to interact for the meaningful exchange of information.

Jitter

The slight movement of a transmission signal in time or phase that can introduce errors and loss of synchronization for high-speed synchronous communications; see Phase Jitter.

Keep Alive Signal

A keep alive signal prevents the network's line regenerators from oscillating (which causes interference with adjacent channels). The network requires that the DSU transmit a keep alive signal when conditions are such that a normal data stream cannot be transmitted.

Leased Line

A dedicated circuit, typically supplied by the telephone company, that permanently connects two or more user locations; generally voice-grade in capacity and in range of frequencies supported; typically analog, though sometimes refers to DDS substrate digital channels (2.4 to 9.6 kbps); used for voice (2000 Series leased line)

GLOSSARY

	or data (3002-type); point-to-point or multipoint; may be enhanced with line conditioning; also private line.
LED	Light-emitting diode.
Line Code Violation Event	For an AMI-coded signal, this is the occurrence of a received bipolar violation. For a B8ZS-coded signal, it is the occurrence of a received bipolar violation that is not part of the associated zero-substitution code.
Link	The combination of communications devices, media and software intelligence that is required to effect data communications.
Loopback	Diagnostic procedure used for transmission devices; a test message is sent to a device being tested, which is then sent back to the originator and compared with the original transmission; loopback testing may be within a locally attached device or conducted remotely over a communications circuit.
Loss of Signal (LOS)	An LOS condition occurs when the DSU senses an absence of signal (no signal) from either side for more than 150 milliseconds when in the AT&T mode, or 175 bit periods when in the ANSI mode. A network signal with loss greater than 30 dB (± 2.5 dB) is considered no signal, while an equipment signal with consecutive zeros is considered no signal. In response to receiving an LOS from one side, the DSU returns a Yellow alarm, and transmits an AIS to the other side.
Modem	Modulator/demodulator; electronic device that enables digital data to be sent over (typically) analog transmission facilities.
Multiplex	The interleaving of message elements (bits and characters) from a variety of data sources into one or more combined signals.
Multiplexed Channel	A communications channel capable of servicing a number of devices, or users, at a time.
Multiplexer	Any multipoint device that allows two or more users to share a common physical transmission medium; employed in pairs, one at each end of the communications channel, where each device performs both multiplexing of the multiple user inputs and demultiplexing of the channel back into the separate user data streams.
Multiplexing	The combining of multiple data channels onto a single transmission medium; any process through which a circuit normally dedicated to a single user can be shared by multiple users; typically, user data streams are interleaved on a bit or byte basis (time division) or separated by different carrier frequencies (frequency division).
Mux	Multiplexer.
Network	An interconnected group of nodes; a series of points, nodes, or stations connected by communications channels; the assembly of equipment through which connections are made between data stations.
Node	A point where one or more functional units interconnect transmission lines (ISO); a physical device that allows for the transmission of data within a network; an end-point of a link or a junction common to two or more links in a network (IBM SNA); typically includes host processors, communications controllers, cluster controllers, and terminals.
NRZ	Non-return to zero; a binary encoding and transmission scheme where "ones" and "zeros" are represented by opposite, and alternating, high and low voltages; where there is no return to a reference (zero) voltage between encoded bits.

Out of Frame State (OOF)	An OOF state begins when any two out of four or two out of five consecutive framing bits received from either side are incorrect. In response to receiving an OOF from one side, the DSU returns a Yellow alarm, and transmits an AIS to the other side. A Red alarm signal occurs when an OOF state exists for more than 2.5 seconds. An OOF state ends when reframe occurs.
PABX	Private automatic branch exchange.
Packet	A sequence of data, with associated control elements, that is switched and transmitted as a whole; refers mainly to the field structure and format defined within the CCITT X.25 recommendation; multiple packets may be required to carry one complete document or a lengthy block of information.
Packet Switching	A data transmission technique wherein user information is segmented and routed in discrete data envelopes called packets, each with its own appended control information for routing, sequencing, and error checking; a transmission technique that allows a communications channel to be shared by many users, each using the circuit only for the time required to transmit a single packet; a network that operates in this manner.
Parity Bit	An additional non-information bit appended to a group of bits, typically to a 7- or 8-bit byte, which indicates whether the number of ones in the group of bits is an odd or even number; a basic and elementary mechanism for error checking.
Parity Check	Process of error checking using the parity bit; varied methods include longitudinal parity check and transverse parity check.
PBX	Private branch exchange; telephone switch located on a customer's premises that primarily establishes voice-grade circuits, over tie-lines, between individual users and the switched telephone network.
Phase Modulation	A data transmission encoding method wherein the phase angle of the carrier wave is varied, usually by 90 or 180 degrees, to represent a different bit value to the receiver; the encoding technique used in phase shift keying. The process of changing the phase of a carrier waveform to reflect digital (binary) information for the purpose of transmission over analog facilities.
Phase Shift Keying (PSK)	The phase-modulation encoding technique employed by many modems.
Point to Point	A circuit that connects two points directly, with generally no intermediate processing nodes or computers, although there could be switching facilities; a type of connection, such as a phone-line circuit, that links two, and only two, logical entities.
Port	A point of access into a computer, a network, or other electronic device; the physical or electrical interface through which one gains access; the interface between a process and a communications or transmission facility.
Private Line	A leased line, an unswitched circuit.
Protocol	Formal set of rules governing the format, timing, sequencing, and error control of exchanged messages on a data network; may also include facilities for managing a communications link and/or contention resolution; a protocol may be oriented toward data transfer over an interface, between two logical units directly connected, or on an end-to-end basis between two end users over a large and complex network.
PSTN	Public switched telephone network; the dial-up phone network.

GLOSSARY

Public Network	Generically, a network established and operated by communications common carriers or telecommunications administrations for the provision of circuit-switched, packet-switched, and leased-line circuits to the public.
Quasi-Random Signal (QRS) Test Pattern	An irregular pattern of bits used to test and measure network jitter, as defined in AT&T PUB 62411.
Red Alarm Signal	A Red alarm signal is a locally detected failure that occurs when an OOF state exists for more than 2.5 seconds. In response to receiving a Red alarm from one side, the DSU transmits a Yellow alarm to the other side.
Request To Send	A signal to the sending modem that the terminal is ready to transmit; part of modem handshaking.
RS-232-C	An EIA-specified physical interface. See EIA/TIA-232-E.
RTS	Request To Send.
Severely Errored Framing Event	This is the occurrence of two or more frame synchronization bit error events within a 3-ms period.
Severely Errored Second (SES)	An SES is a second with 320 or more ESF error events. SESs are also processed to derive an unavailable signal state.
Simplex	One-way data transmission, with no capability for changing direction.
SNA	Systems Network Architecture. In IBM networks, the layered logical structure, formats, protocols, and procedures that govern information transmission.
Space	One of the two possible conditions of an information element (bit), an open line in a neutral circuit.
Start Bit	In asynchronous transmission, the first element in each character that prepares the receiving device to recognize the incoming information elements.
Start-Stop Transmission	Asynchronous transmission for a group of data elements that are preceded by a start signal and followed by a stop signal; reference employed primarily by IBM for asynchronous transmission.
Stop Bit	In asynchronous transmission, the last transmitted element in each character, which permits the receiver to come to an idle condition before accepting another character.
Supervisory Port	An interface on the 552A-1 V1.1 to which the Supervisory terminal is connected.
Supervisory Terminal	A terminal that provides software-control of configuration, diagnostics, and maintenance for one or all 552A-1 V1.1s in a network.
Switched Network	Communications link for which the physical path, established by dialing, may vary with each use (e.g., a dial-up telephone circuit).
Systems Network Architecture (SNA)	In IBM networks, the layered logical structure, formats, protocols, and procedures that govern information transmission.

T1	AT&T term for a digital carrier facility used to transmit a DS-1 formatted digital signal at 1.544 Mbps.
Telco	Telephone company.
Terminal	A point in a network at which data can either enter or leave; a device, usually equipped with a keyboard, often with a display, capable of sending and receiving data over a communications link (IBM); generically the same as data terminal equipment (DTE).
Tie Line	A leased or private line dedicated telephone circuit provided by common carriers that links two points together without using the switched telephone network.
Transmission	The dispatching of a signal, message, or other form of intelligence by wire, radio, telegraphy, telephony, facsimile, or other means (ISO); a series of characters, messages or blocks, including control information and user data; the signalling of data over communications channels.
2047-Bit Test Pattern	An irregular, quasi-random pattern of 2,047 bits used to test and measure network jitter.
Unavailable Second (UAS)	A UAS is counted for every second an unavailable signal state exists.
Unavailable Signal State	An unavailable signal state occurs when 10 consecutive severely ESs occur. An unavailable signal state ends when 10 consecutive seconds of data are processed and no severely ESs occur. While in an unavailable signal state, no ESs are counted. For every second an unavailable signal state exists, a UAS results.
USOC	The Universal Service Order Code (USOC) is accepted telecommunications industry code for identifying servicing arrangements provided by telephone companies, and is used to identify the standard jack required for the equipment.
Virtual Circuit	A connection established between a channel from the calling DTE and a channel to the called DTE before any data packets may be sent. May be a Switched Virtual Circuit (SVC) or a Permanent Virtual Circuit (PVC).
Voice-Grade Channel	A telecommunications circuit used primarily for speech transmission but suitable for the transmission of analog or digital data or facsimile; typically supporting a frequency range of 300 to 3,400 Hz; also voice band.
Yellow Alarm Signal	A Yellow alarm signal is a remotely detected failure. A Yellow alarm is transmitted as a specific bit pattern contained in the data stream when using D4 framing, or in the data link when using ESF framing. In response to receiving a Yellow alarm from one side, the DSU transmits a Yellow alarm to the other side in the proper format (D4 or ESF).

INDEX

- Alternate DS0 option selection, 2-17, 3-44, 3-48
- Alternate Mark Inversion (AMI), see Line Code
- Applications, 1-3
 - dial-up modem, 1-4, 2-4, 2-19, 2-26 3-5
 - direct connection, Supervisory terminal, 1-4, 2-24, 2-26, 3-1
 - PMC-100, 1-4, 2-46 2-12, 2-20, 2-26
- Auto Framing option selection, 2-11, 2-29, 3-41
- Bipolar with Eight Zeros Substitution (B8ZS), see Line Code
- Channel Configuration screen, 3-44
- Channel Data Rate option selection, 2-36, 3-47,
- Channel Diagnostics screen, 3-13
- Channel Diagnostics, 4-26
- Channel Digital Loop, 4-26
- Channel flow control options, 2-5, 2-18, 2-33, 2-37
- Channel port connection, 2-20, 2-38, 2-41, -2-45,
- Channel RDL Response option selection, 2-32, 3-48, C-2
- Channel Remote Digital Loop, 4-29
- Channel Remote Digital Loop with Self-Test, 4-31
- Channel Self-Test, 4-32
- Clear Channel Capability, 3-41
- Configuration Mode option selection, 2-31
- Connections, electrical, 2-20
 - cable applications, 2-46 - 2-50
 - channel port, 2-20
 - connector function assignments, 2-38
 - grounding jumper, 2-28
 - network port, 2-20, 2-22, 2-23, 2-38, 2-46, 2-49
 - primary power, 2-27
 - Supervisory port, 2-24
- Consecutive zeros, see Ones Density
- CSU Configuration screen, 3-40
- CSU Self-Test screen, 3-35
- CTS Operation option selection, 2-33, 3-46
- D4 Frame Format, see Network Frame Format
- DataComm Enclosure
 - channel port connection, 2-20
 - cover removal procedure, 2-10
 - installation, 2-23
 - network port connection, 2-22
 - primary power connection, 2-27
 - Supervisory port connection, 2-24
- DataComm FourPak Enclosure
 - channel port connection, 2-48
 - installation, 2-2
 - network port connection, 2-22
 - primary power connection, 2-27
 - Supervisory port connection, 2-24
- DataComm Shelf
 - channel port connection, 2-48
 - grounding jumper connection, 2-28
 - installation, 2-2
 - network port connection, 2-22
 - primary power connection, 2-27
 - Supervisory port connection, 2-24
- Date
 - display, 3-7, 3-8
 - set, 3-50
- Diagnostics, see specific tests
- Dial-up modem application, 1-3, 2-19, 2-26, 3-5
- DS0 Circuit Delay Measurement Test, 4-21
- DS0 Diagnostics screen, 3-15
- DS0 Diagnostics, 4-21
- DS0 Remote Test, 4-33
- DS0 Remote Test with Self-Test, 4-24
- DS0 Self-Test, 4-25
- DS1 Diagnostics, 4-8
- DS1 Interface Connector, 3-38, 4-4, 4-6
- DS1 Line Loop, 4-8
- DS1 Line Loop with Self-Test, 4-9
- DS1 Line Loopback function, 4-6
- DS1 Local Test with Self-Test, 4-10
- DS1 Loopback Functions, 4-4
- DS1 Network Interface Loopback function, 4-6
- DS1 Network Interface Loopback, 4-11
- DS1 Network Interface Loopback with Self-Test, 4-11
- DS1 Remote Test, 4-14
- DS1 Remote Test with Self-Test, 4-16
- DS1 Self-Test, 4-18
 - pattern selection, 2-29
- DS1 Test Loop, 4-19
- DS1 Test Loop with Self-Test, 4-20
- DS1 Test Loopback function, 4-7
- DSU address number
 - display, 3-7, 3-8
 - option selection, 2-13, 2-30, 2-34
- DTE Loopback, 4-7
- EIA-530 Channel Interface Card (optional), 1-1, 1-7
- Extended Superframe Format (ESF), see Network Frame Format
- Fault isolation, 4-1
- Firmware revision level display, 3-7, 3-8
- Fractional T1 capabilities, 1-4
- Front panel, 3-1
 - indicators, 3-1
 - inhibit test switches option, 2--30
 - switches, 3-1
 - test jacks, 3-1
- GDC TriPak Shelf
 - channel port connection, 2-20
 - installation, 2-2
 - network port connection, 2-22
 - primary power connection, 2-27
 - Supervisory port connection, 2-24
- Ground option selection, 2-28
- Grounding jumper connection, 2-28, 2-52
- In-band communications, Supervisory terminal, 2-6

- In-band loopback code
 - detection option selection, 2-12, 3-36
 - framing option selection, 2-11, 2-29, 3-42
 - test type option selection, 2-11, 2-29, 3-36
- Indicators, front panel, 3-1
- Installation
 - DataComm Enclosure, 2-2, 2-22, 2-23, 2-35
 - DataComm FourPak Enclosure, 2-2
 - DataComm Shelf, 2-2
 - GDC TriPak Shelf, 2-2
 - procedures, 2-1
 - Universal System Shelf, 2-3
- Line Code option selection, 2-29, 3-41
- Local User Twenty-Four Hour Report screen, 3-25
- Log-on screen, 3-7
- Loopbacks screen, 3-37
- Main Menu, 3-9
- Maintenance screen, 3-50
- Memory status display, 3-7
- Network Compatibility option selection, 2-31, 3-41
- Network Frame Format option selection, 2-29, 3-41
- Network Line Build-Out
 - display, 3-39
 - option selection, 2-31, 3-39
- Network performance error description, 3-18
- Network port connection, 2-22
- Ones Density option selection, 2-29, 3-42
- Option
 - selection, 2-3, 2-11
 - switch location, 2-3, 2-4, 2-8, 2-9
- Out-of-band communications, Supervisory terminal, 2-4, 2-18, 3-6
- Payload Loopback, 4-7
- Performance Report Messages, 3-34
- PMC-100 Performance Monitor Card, 1-1, 1-4, 2-4, 2-26, 3-5, 3-6
 - option selection, 2-30
- Preoperational check, 2-1
- Primary power connection, 2-27
- Rear panel option jumper, 2-24
- Receive Level screen, 3-39
- Remote Network Twenty-Four Hour Report screen, 3-31
- Remote User Twenty-Four Hour Report screen, 3-29
- Scheduled Performance Report screen, 3-33
- Soft Configuration Privileges
 - application, 2-6, 3-6
 - option selection, 2-30
 - option, 2-6, 3-6
- Status line, 3-8
- Supervisory terminal
 - accessing a DSU, 3-1
 - Channel Configuration screen, 3-44
 - Channel Diagnostics screen, 3-13
 - character format selection, 2-30
 - CSU Configuration screen, 3-40
 - CSU Self Test screen, 3-35
 - data rate selection, 2-30
 - dial-up modem application, 1-3, 2-19, 2-26, 3-5
 - direct communication application, 1-4, 3-1
 - display information, 3-8
 - DS0 Diagnostics screen, 3-15
 - electrical connection, 2-20
 - interface characteristics, 2-20
 - keyboard usage, 3-8
 - Local User Twenty-Four Hour Report screen, 3-25
 - log-on screen, 3-7
 - Loopbacks screen, 3-37
 - Main Menu, 3-9
 - Maintenance screen, 3-50
 - Remote Network Twenty-Four Hour Report screen, 3-31
 - Remote User Twenty-Four Hour Report screen, 3-29
 - Soft Configuration Privileges option selection, 2-30
 - Soft Configuration Privileges option, 3-6
 - menu organization, 3-5
 - operating procedures, 3-1
 - Receive Level screen, 3-39
 - Scheduled Performance Report screen, 3-33
 - status line, 3-9
 - T1 Alarm History screen, 3-20
 - T1 Diagnostics Menu, 3-18
 - Twenty-Four Hour Reports menu, 3-24
- Switches, front panel, 3-1
 - inhibit switches option, 2-30
- T1 Alarm History screen, 3-20
- T1 Diagnostics Menu, 3-18
- TABS Maintenance Messages, 1-1, 2-31, 3-41
- Technical assistance procedure, 4-33
- Technical characteristics, A-1
- Test jacks, front panel, 3-1
- Tests, see specific tests
- Time
 - display, 3-7
 - set, 3-50
- Timing options, 2-7, 2-15, 2-24
- Training, 4-34
- Twenty-Four Hour Reports menu, 3-24
- Universal System Shelf
 - channel port connection, 2-20
 - installation, 2-22
 - network port connection, 2-22
 - primary power connection, 2-27
 - Supervisory port connection, 2-24
- Unpacking and handling, 2-1

PATENT NOTICE

ANALOOP® is a patented method and apparatus of General DataComm, Inc. (U.S. Patent 3,655,915).

DATALOOP® is a patented method and apparatus of General DataComm, Inc. (U.S. Patent 3,769,454).

TRADEMARK NOTICE



® and the following are Trademarks of General DataComm, Inc.

ACCULINE®	LAN*TMS™
ANALOOP®	MEGA*BRIDGE®
AUTOFRAME®	MEGAMUX®
BERT 901®	MEGAMUX TMS®
DATAComm SECURE-PAK®	MEGANET®
DATALOOP®	MEGASPLIT®
DATX® (Canada Only)	MEGASWITCH®
DATX SWITCHING SYSTEM® (Canada Only)	MEGAVIEW®
DIGIDIAL®	MULTIMODEM®
FIRST RESPONSE®	NETCON®
GDC®	NETSWITCH®
General DataComm®	NMC®
General DataComm X-PRESS 24®	NMS® (Canada Only)
GEN*NET®	Quikshippers®
GEN*PAC®	SERVI-CHECK®
IMAGE*TMS™	SERVI-SNAP®
KILOMUX®	STATKAT® (Canada Only)

WARRANTY NOTICE

WARRANTIES: General DataComm, Inc. (hereafter referred to as GDC), warrants that its equipment is free from any defects in materials and workmanship. The warranty period shall be one year from the date of shipment of equipment. GDC's sole obligation under its warranty is limited to the repair or replacement of the defective equipment provided it is returned to GDC, transportation prepaid, within a reasonable period. This warranty will not extend to equipment subjected to accident, misuse, or alterations or repair not made by GDC or authorized by GDC in writing. THE FOREGOING WARRANTY IS EXCLUSIVE AND IN LIEU OF ALL OTHER WARRANTIES, EXPRESSED OR IMPLIED, INCLUDING, BUT NOT LIMITED TO, WARRANTIES OF MERCHANTABILITY AND FITNESS FOR PURPOSE.

TABLE OF CONTENTS

