

INSTRUCTION MANUAL
FOR

DPS-7A POWER SUPPLY

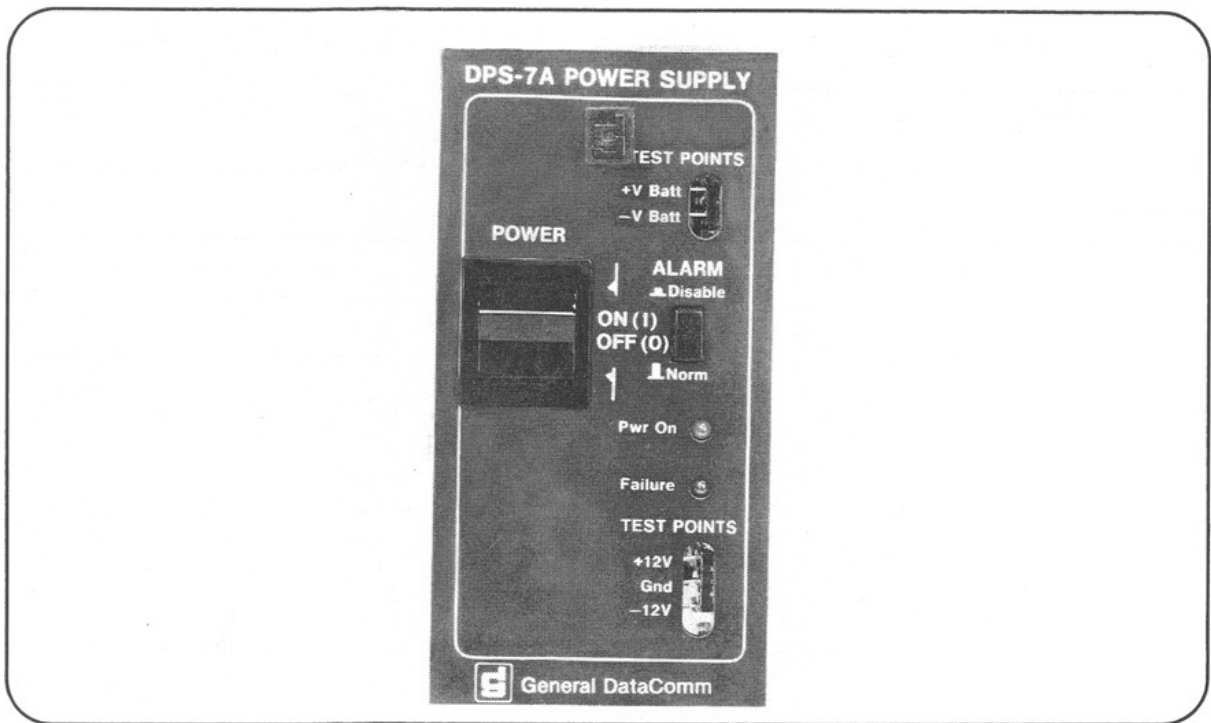

General DataComm, Inc.
MIDDLEBURY, CONNECTICUT
06762-1299



ATTENTION! STATIC SENSITIVE DEVICES

PROPER HANDLING AND GROUNDING PRECAUTIONS REQUIRED

This equipment contains electrostatic sensitive devices. Use ESD precautionary procedures when removing or inserting parts or printed circuit (pc) cards. Keep parts and pc cards in their antistatic packaging material until ready to install.

The use of an antistatic wrist strap, connected to the grounded equipment frame or chassis, is recommended when handling pc cards during installation, removal, or setting of on-board option switches. Do not use a conductive tool, such as a screwdriver or paper clip, to set the position of the option switches.



INSTALLATION SAFETY INSTRUCTIONS

- a. Never install telephone wiring during a lightning storm.
- b. Never install telephone jacks in a wet location unless the jack is specifically designed for wet locations.
- c. Never touch uninsulated telephone wires or terminals unless the telephone line has been disconnected at the network interface.
- d. Use caution when installing or modifying telephone lines.

CAUTION

Potentially hazardous voltages exist within this unit.

ERRATA SHEET
FOR

DPS-7A POWER SUPPLY

Page 1-2 — **TABLE 1-1. EQUIPMENT LIST** — Delete old alarm cable number 041H033-001A and add two new numbers: 041H003-004 — 4 ft. cable, and 041H003-010 — 10 ft. cable.

Page 2-2 — Sub-paragraph **External Alarm Connections** — To clarify connection of cable 041H003 to either "A" or "B" ALARM headers: Delete the existing text and add: Cable 041H003 has P1 connector on one end and six spade lugs on the other end. The spade lugs can be connected to a customer provided terminal block and from there (using the appropriate wire) to a frame block if that is the routing point to the customers alarm circuitry. The wiring designation and wire color code for each leg of the alarm relay is shown in Figure 2-4.

The functions of Alarms A and B are described in Figure 3-2.

Page 2-6 — **FIGURE 2-14. ALARM CABLE ASSEMBLY (041H003-001A)**

Delete part no. in parenthesis and add: (GDC PART NO. 041H003-XXX) — Add reference to 4 foot and 10 foot lengths to drawing, show a white dot on P1 to indicate pin number one, and show six spade lugs at end of cable instead of three.

Page 3-2 — **FIGURE 3-1. DPS-7A POWER SUPPLY FRONT PANEL** — Under "INDICATORS" description of **Failure**, delete the existing description and add:

Red LED indicator lights when there is a failure on the bus or a power supply failure. When the bus fails, all redundant supplies will show a lit Failure LED. When the supply fails, only the Failure LED on that supply will light. There are numerous reasons for a power supply failure which are beyond the scope of this manual; however, a failure can exist if one of the following conditions exists: output overvoltage or undervoltage, a short circuit on the output.

WARNING

This equipment has been tested and found to comply with the limits for a Class A digital device, pursuant to Part 15 of the FCC rules. These limits are designed to provide reasonable protection against harmful interference when the equipment is operated in a commercial environment. This equipment generates, uses and can radiate radio frequency energy and, if not installed and used in accordance with the instruction manual, may cause harmful interference to radio communications. Operation of this equipment in a residential area is likely to cause harmful interference, in which case the user will be required to correct the interference at his own expense.

The user is cautioned that any changes or modifications not expressly approved by the party responsible for compliance would void the user's authority to operate the equipment.

CRC-REQUIRED NOTIFICATION

This equipment is a Class A digital apparatus which complies with the Radio Interference Regulations, CRC c.1374.

PUBLICATION NOTICE

This manual has been carefully compiled and checked for accuracy. The information in this manual does not constitute a warranty of performance. Furthermore, GDC reserves the right to revise this publication and make changes from time to time in the content thereof. GDC assumes no liability for losses incurred as a result of out-of-date or incorrect information contained in this manual.

The features described herein may not exist on all versions of the software and are subject to change without notice.

READER'S COMMENTS

Comments regarding this manual should be addressed to:

**Publications Department
General DataComm, Inc.
1579 Straits Turnpike
P.O. Box 1299
Middlebury, CT 06762-1299**

PROPRIETARY NOTICE

This publication contains information proprietary and confidential to General DataComm, Inc. Any reproduction, disclosure, or use of this publication is expressly prohibited except as General DataComm, Inc., may otherwise authorize in writing.

Copyright, General DataComm, Inc., 1994

FCC-REQUIRED NOTIFICATION

FOR USERS OF FCC-REGISTERED EQUIPMENT

Read before using this technical manual or installing subject equipment.

This equipment complies with Part 68 of the Federal Communications Commission (FCC) Rules and Regulations. Connection of data communication equipment to the public telephone network is regulated by the FCC Rules and Regulations. These regulations require:

- A. All connections to the telephone network must be made through standard plugs and telephone company provided jacks or equivalent.
- B. Connection of this equipment to party lines and coin telephones is prohibited.
- C. If the telephone company asks you what equipment is connected to the telephone line, tell them to which line the equipment is connected, and give them the FCC Registration number and Ringer Equivalence number of the equipment. These numbers can be found on a label located on the back of the front panel on all DataComm-type equipment and on the underside or rear panel of other equipment.
- D. If you experience trouble, disconnect the equipment from the telephone line to determine if the equipment is malfunctioning. If it is, remain disconnected until the problem is corrected. Should this equipment cause harm to the telephone network, the telephone company may discontinue your service temporarily. If possible they will notify you in advance. But if advance notice is not practical, you will be notified as soon as possible. You will be informed of your right to file a complaint with the FCC.
- E. The telephone company may change its communication facilities, equipment, operations, and procedures where reasonably required for operation. If this occurs, the telephone company will notify you in writing.
- F. It is the user's obligation to notify the telephone company prior to disconnecting equipment from 1.544 Mbps digital service.
- G. According to Part 68 of the FCC Rules and Regulations, customers are not authorized to repair or modify this equipment. Any repair or modification will null and void the FCC registration and the warranty of this equipment.

CANADIAN DEPARTMENT OF COMMUNICATIONS (DOC) REQUIRED NOTIFICATION

FOR USERS OF DOC-CERTIFIED EQUIPMENT

Read before using this technical manual or installing subject equipment.

The Canadian Department of Communications label identifies certified equipment. This certification means that the equipment meets certain telecommunications network protective, operational, and safety requirements. The Department does not guarantee the equipment will operate to the user's satisfaction.

Before installing this equipment, users should ensure that it is permissible to be connected to the facilities of the local telecommunications company. The equipment must also be installed using an acceptable method of connection. In some cases, the company's inside wiring associated with a single line individual service may be extended by means of a certified connector assembly (telephone extension cord). The customer should be aware that compliance with the above conditions may not prevent degradation of service in some situations.

Repairs to certified equipment should be made by an authorized Canadian maintenance facility designated by the supplier. Any repairs or alterations made by the user to this equipment, or equipment malfunctions, may give the telecommunications company cause to request the user to disconnect the equipment.

Users should ensure for their own protection that the electrical ground connections of the power utility, telephone lines, and internal metallic water pipe system, if present, are connected together. This precaution may be particularly important in rural areas.

Caution: Users should not attempt to make such connections themselves, but should contact the appropriate electric inspection authority, or electrician, as appropriate.

CANADIAN EMISSIONS REQUIREMENTS

"This digital apparatus does not exceed the (ClassA) limits for radio noise emissions from digital apparatus set out in the Radio Interference Regulations of the Canadian Department of Communications."

TABLE OF CONTENTS

Section & Subject	Page
SECTION 1 – GENERAL INFORMATION	
OVERVIEW	1-1
PHYSICAL DESCRIPTION	1-1
DPS-7A EQUIPMENT	1-1
SERVICE AND TRAINING	1-1
SECTION 2 – INSTALLATION	
UNPACKING AND HANDLING	2-1
PREOPERATIONAL CHECK	2-1
INSTALLATION PROCEDURES	2-1
ELECTRICAL CONNECTIONS	2-2
Primary Power Connections	2-2
External Alarm Connections	2-2
SECTION 3 – OPERATION	
OVERVIEW	3-1
SECTION 4 – PRINCIPLES OF OPERATION	
OVERVIEW	4-1
INPUT CIRCUITS	4-1
DRIVE AND CLOCK CIRCUITS	4-1
OUTPUT CIRCUITS	4-3
OVERCURRENT SHORT CIRCUIT AND OVERVOLTAGE PROTECTION	4-3
ALARM	4-4
SECTION 5 – TESTS	
OVERVIEW	5-1
FUSE REPLACEMENT	5-1
TECHNICAL ASSISTANCE PROCEDURE	5-1
TRAINING	5-2
SECTION 6 – PARTS LIST	
OVERVIEW	6-1
SECTION 7 – DIAGRAMS	
OVERVIEW	7-1
APPENDIX A – TECHNICAL CHARACTERISTICS	
APPENDIX B – GLOSSARY	
INDEX	

LIST OF ILLUSTRATIONS

Section & Figures	Page
SECTION 1 — GENERAL INFORMATION	
1-1 DPS-7A DC-to-DC Power Supply Module.....	1-2
SECTION 2 — INSTALLATION	
2-1 -48 V dc Station Single Battery Connection.....	2-3
2-2 Redundant Battery System with Common Positive Terminals.....	2-4
2-3 DPS-7A Option Selection.....	2-5
2-4 Alarm Cable Assembly (041H003-001A).....	2-6
SECTION 3 — OPERATION	
3-1 DPS-7A Power Supply Front Panel.....	3-2
3-2 DPS-7A Power Supply, Shelf Rear Panel.....	3-3/4
PRINCIPLES OF OPERATION	
4-1 DPS-7A Power Supply Functional Block Diagram.....	4-2
SECTION 7 — DIAGRAMS	
7-1 DPS-7A Power Supply PCB Assembly Diagram (041P023-002)	7-2
7-2 DPS-7A Power Supply, Schematic Diagram (041S023-001) (2 Sheets)	7-3

LIST OF TABLES

Section & Tables	Page
SECTION 1 — GENERAL INFORMATION	
1-1 Equipment List.....	1-2
SECTION 6 — PARTS LIST	
6-1 Parts List DPS-7A PCB (041P023-002)	6-1

SECTION 1

GENERAL INFORMATION

OVERVIEW

The DPS-7A (see Figure 1-1) is a fully redundant dc-to-dc switching power supply designed to supply power to a number of GDC rackmount shelves. The modular plug-in supply provides isolated regulated output voltages of ± 12 V dc, in redundancy with a second optional and identical plug-in power supply with the option of a separate battery input, from a nominal battery voltage of -48 V dc. The redundant configuration allows the GDC DPS-7A to be removed without interrupting the operation of the remaining power supply, thus providing uninterrupted power to the load.

NOTE

An important feature of the DPS-7A power supply is a share function which forces two DPS-7A power supply modules to "share" equally in supplying the load. Please refer to CAUTION notes when installing the modules.

Overvoltage protection is provided on all outputs to prevent voltages from exceeding safe levels. A unique over-current circuit provides current limiting for overload and short circuit protection. The DPS-7A also incorporates output-to-output short and reverse voltage protection. A voltage sensing failure alarm provides visual indication via a front panel alarm LED and remote indication through the deenergization of relay contacts that are brought out to rear panel jacks. One set of contacts may be disabled from a front panel switch. All operating controls and indicators are located on the unit's front panel.

PHYSICAL DESCRIPTION

The DPS-7A plug-in modules are rackmount units that are vertically stacked (up to two) when viewed from the front of a shelf. The front panel on each supply has a POWER on/off rocker switch, an ALARM norm/disable switch, battery input and power supply output test points, a red Failure LED status indicator, and a green Pwr On LED status indicator. The rear panel mounts a six-position terminal block for connecting the station battery or batteries and two 7-pin external headers for each power supply.

DPS-7A EQUIPMENT

Part numbers and optional equipment for the GDC DPS-7A are listed in Table 1-1.

SERVICE AND TRAINING

See Section 5, Tests, for information on service and training available from GDC.

TABLE 1-1. EQUIPMENT LIST

Item	Description	GDC Part No.
DPS-7A Power Supply	-48 V dc to \pm 12 V dc power supply. Two DPS-7A Power Supplies can be installed for redundant operation.	(041P023-002)
Blank card	Used to fill vacant slot in nonredundant configuration.	010C040-001
Alarm cable assembly (optional)	Used for connection to power supply alarm bus.	041H003-001A

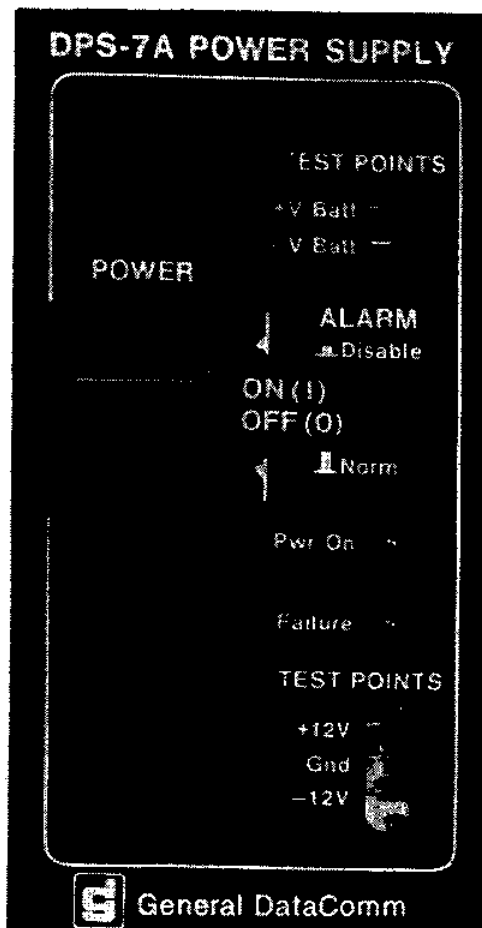

FIGURE 1-1. DPS-7A DC-TO-DC POWER SUPPLY MODULE

SECTION 2 INSTALLATION

UNPACKING AND HANDLING

The DPS-7A is shipped in packing material enclosed in a corrugated box. Carefully open box and remove the power supply from the packing material. Inspect for damage; if any, notify the shipper immediately. Do not discard the box and packing material; their use facilitates reshipping the unit, if necessary.

PREOPERATIONAL CHECK

The power supply should be given a preoperational check by checking output voltages at the front panel test points. Follow these steps:

- a. Check fuse on printed circuit (pc) card. Ensure **POWER** on/off front panel switch is in the off position (down).
- b. Connect station battery to terminal strip at shelf's rear panel (Figure 2-1).
- c. Set **POWER** switch to on. Green Pwr On indicator lights.
- d. Check the input (station battery) and the output voltages at the front panel test points, using appropriate multimeter.

CAUTION

Although the DPS-7A power supply is short circuit protected, it is recommended that these voltage measurements be taken using "easy hook" type probes to prevent the possibility of inadvertently shorting the probes to the front panel.

- e. Set **POWER** switch off.

In the event that the power supply does not check out properly, replace it with a spare unit, if available, and repeat the test. Do not attempt to repair the unit. For assistance, contact DataComm Service Corporation (refer to Technical Assistance Procedures in Section 5).

INSTALLATION PROCEDURES

NOTE

Each power supply module should be inserted with the Power On/Off switch in the off position (down).

The DPS-7A power supply modules plug into the front of the selected shelf. The top slot in the shelf is power supply compartment "A"; the bottom slot is the "B" position.

Using both hands, slide modules into guides and seat firmly. To remove a module, grip knob on the front panel and pull out module.

**ELECTRICAL
CONNECTIONS**

**Primary Power
Connections**

Single battery — At the power supply module's rear panel, jumper together the "A" and "B" screw terminals using short lengths of wire. Connect the 48-volt station battery leads to the +V BAT and to the -V BAT screw terminals being sure to observe polarity. (Refer to Figure 2-1.)

Redundant Battery System With Common Positive Terminals — With this connection power supplies A and B are redundant; if one power supply fails, the other will supply power to the slots in the shelf. To disable redundant operation, cut jumpers X1 through X4 which are located under the cover plate on the power supply's backplane. When the jumpers are cut, power supply "A" will power half of the slots and power supply "B" will power the other half. (Refer to Figure 2-2.)

**WARNING
HAZARDOUS VOLTAGE**

The "share" function option jumpers, X1 and X2, located on the printed circuit card must be moved to the OUT position when X1 through X4 on the backplane are cut, otherwise hazardous voltages may be present. Refer to Figure 2-3.

The power supply terminal block also provides for signal ground, SIG GND and frame ground, FR GND.

**External Alarm
Connections**

If used, connect to the 7-pin "A" and "B" ALARM headers associated with each power supply using alarm cable assembly No. 041H003-001A. Figure 2-4 shows the alarm cable and describes the pin numbers of the headers.

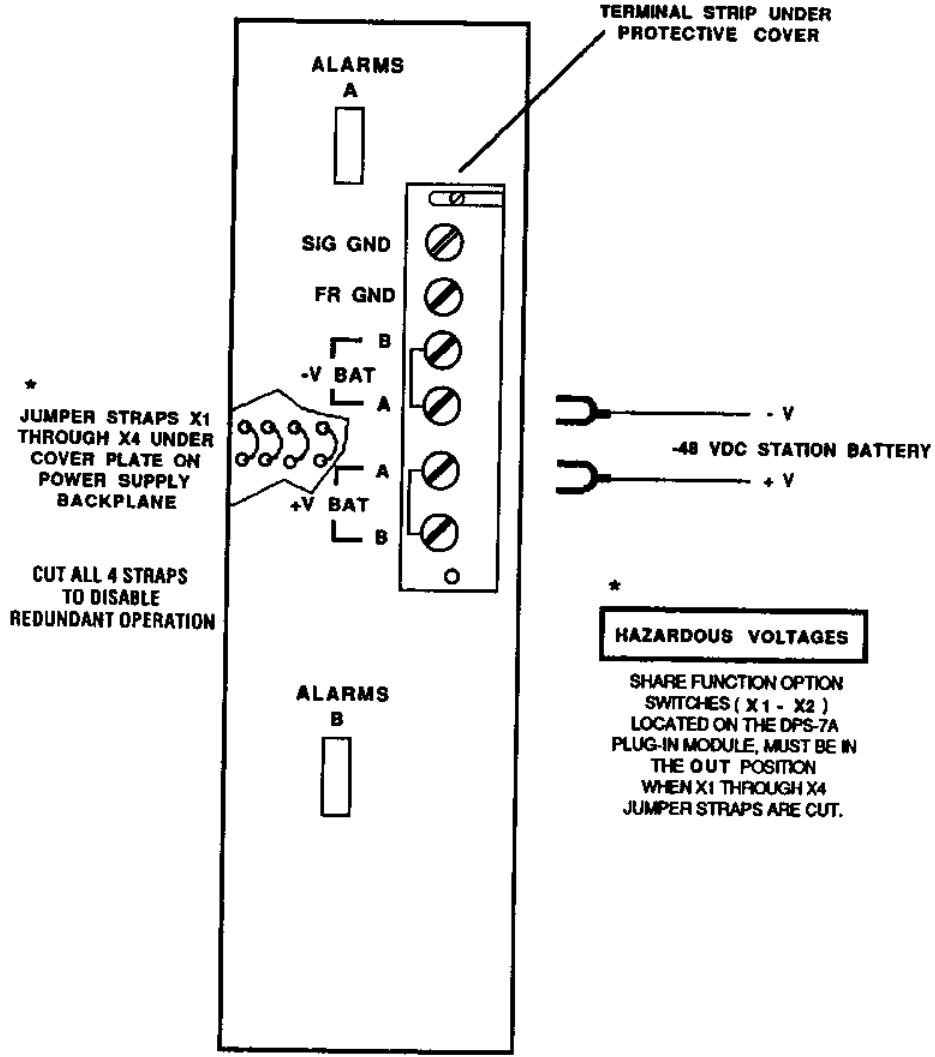

FIGURE 2-1. -48 V DC STATION SINGLE BATTERY CONNECTION

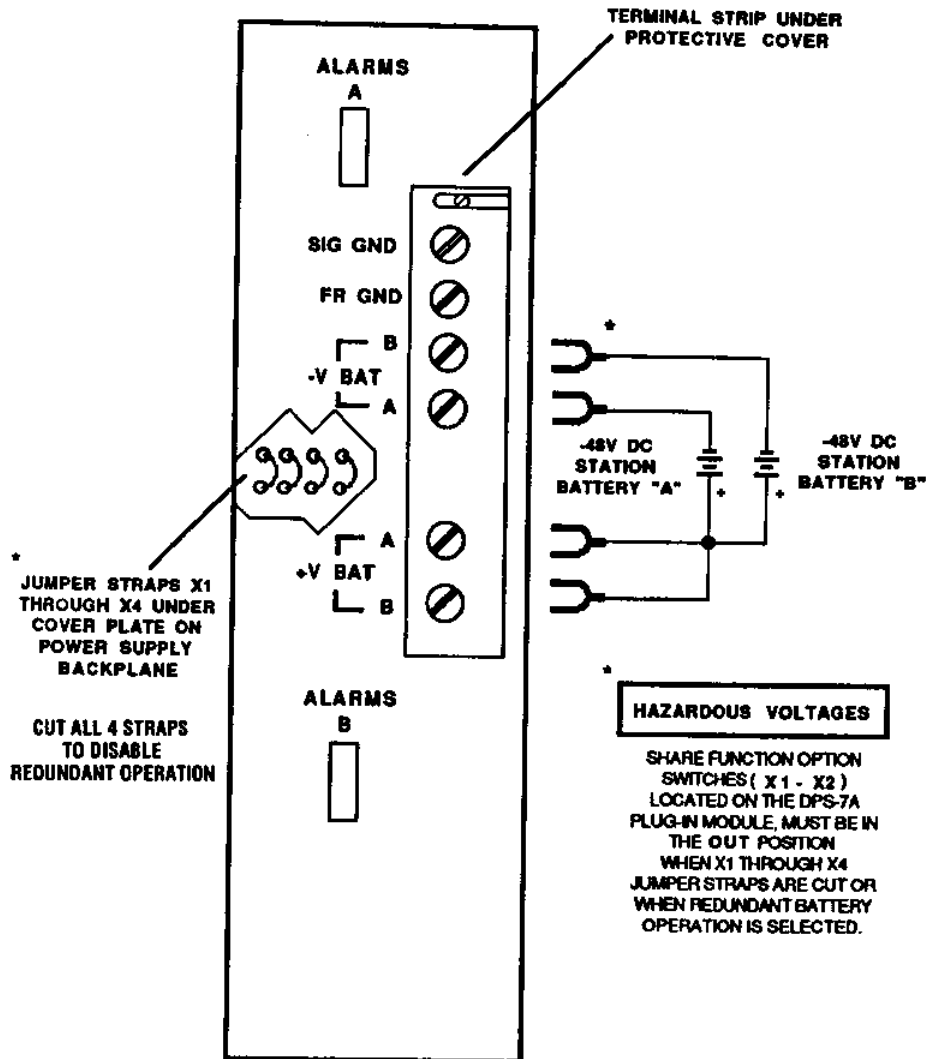

FIGURE 2-2. REDUNDANT BATTERY SYSTEM WITH COMMON POSITIVE TERMINALS

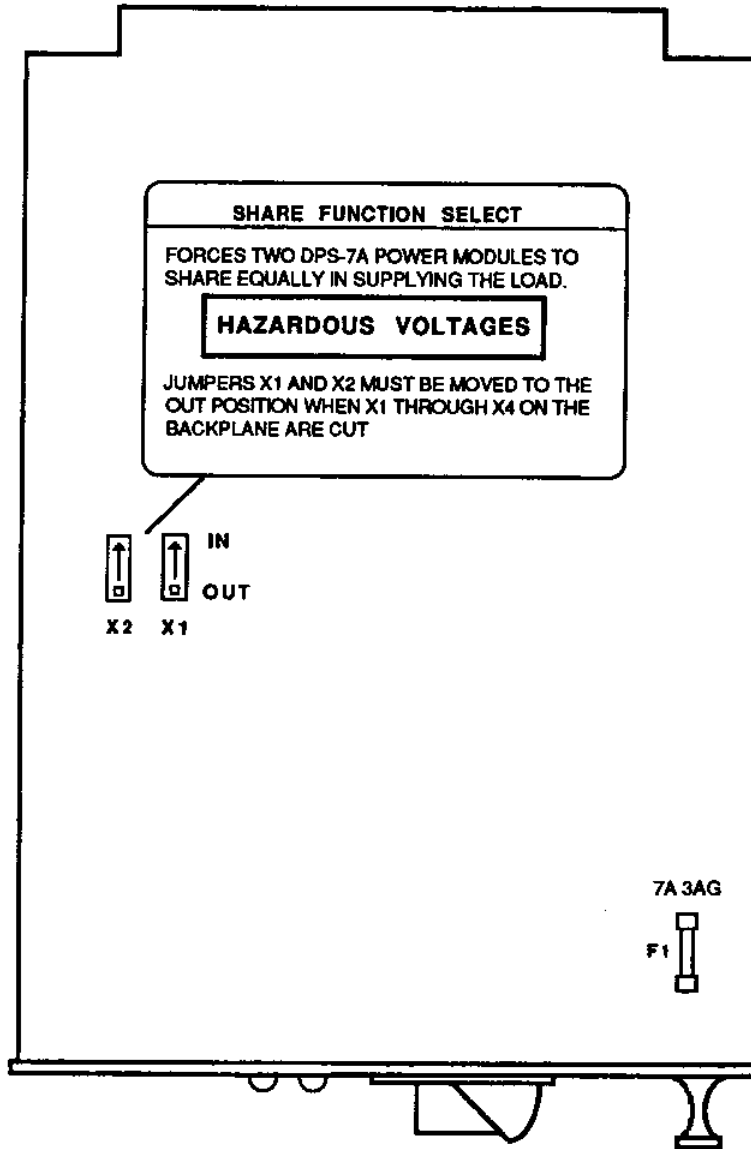
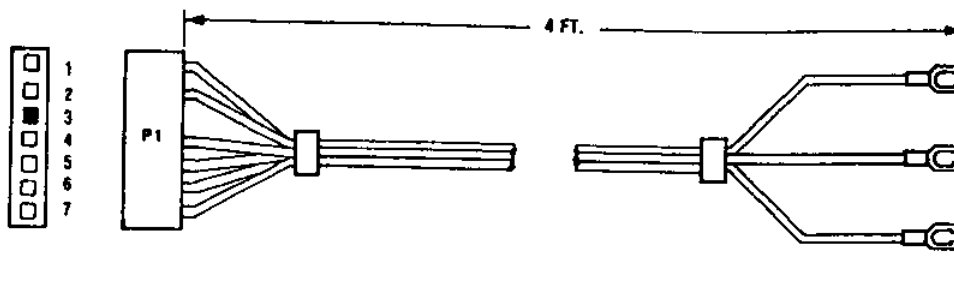

FIGURE 2-3. DPS-7A OPTION SELECTION

SECTION 041R171-000-2



P1	BLK	NORMALLY OPEN	} NO CUT-OFF
1	BRN	NORMALLY CLOSED	
2	YEL	COMMON	} WITH CUT-OFF VIA FRONT PANEL ALARM SWITCH
6	ORN	NORMALLY CLOSED	
5	RED	NORMALLY OPEN	
4	BLUE	COMMON	

FIGURE 2-4. ALARM CABLE ASSEMBLY (041H003-001A)

SECTION 3 OPERATION

OVERVIEW

After plugging the modules into the selected shelf, the only operational requirement for the DPS-7A power supply is turning it on. To turn the power supply on, set the front panel **POWER** switch on (up position). The **Pwr On** indicator will light, signaling that power sequencing is completed and dc voltages are available. Maximum loading output currents are listed in Appendix A at the end of this manual.

The power supply front panel is shown in Figure 3-1. Functions of the front panel switches, indicators, and test points are described in this illustration.

The connectors on the rear panel of the power supply are shown and described in Figure 3-2.

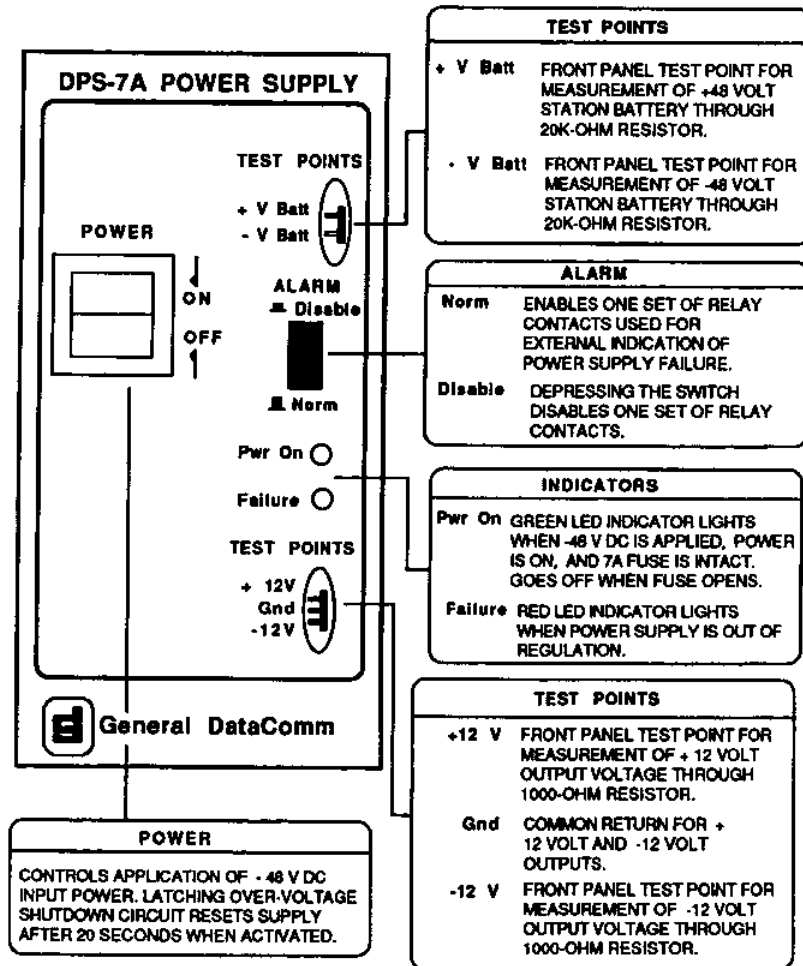

FIGURE 3-1. DPS-7A POWER SUPPLY FRONT PANEL

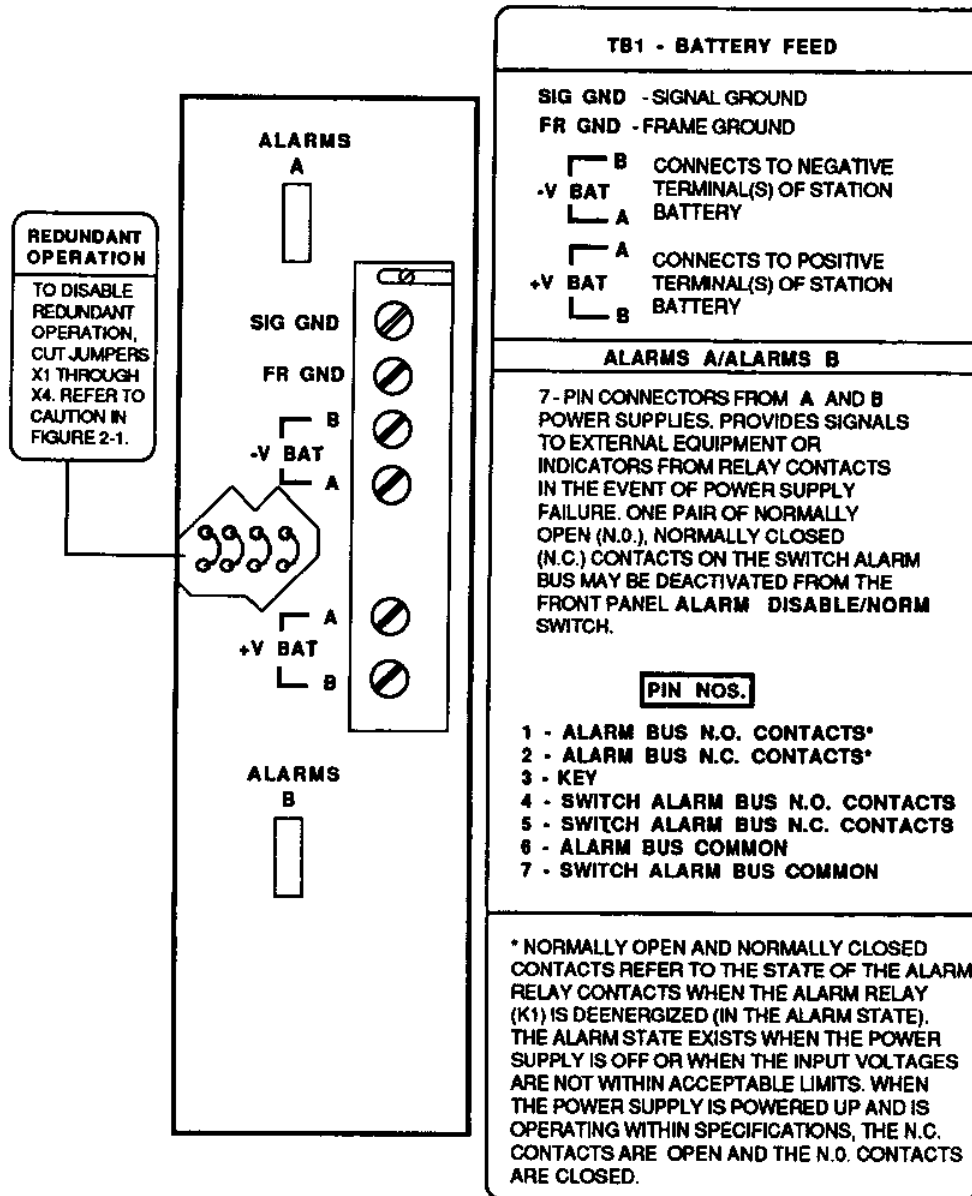

FIGURE 3-2. DPS-7A POWER SUPPLY, SHELF REAR PANEL

SECTION 4

PRINCIPLES OF OPERATION

OVERVIEW

This section describes the circuit functions of the DPS-7A power supply. Refer to the block diagram in Figure 4-1. The major active components (integrated circuits, transistors, etc.) are called out in each block, and may be cross-referenced on the associated schematic diagrams in Section 7. In some cases, gates and minor circuitry are not noted on the block diagram.

The DPS-7A power supply is a switched mode power supply that converts -48 V dc (nominal) to regulated ± 12 V dc $\pm 4\%$ outputs. It can deliver up to 160 watts (at 50°C, free air) and can operate in redundant or nonredundant modes without modification.

NOTE

Refer to precautionary information when connecting redundant power supplies in common positive terminal configurations.

The DPS-7A power supply complies with the following safety standards: UL 478, FCC part 68, and FCC part 15. For EMI (Electro Magnetic Interference) performance, it complies with FCC part 15.

INPUT CIRCUITS

Input power flows into the power supply from the station battery and the thermistor (RT1) limits in-rushing current to 25 amperes maximum. Following the thermistor, input power flows through an EMI filter (L1).

A housekeeping power disable stops the input filter from being discharged quickly when the power supply is turned off. If the power supply is turned on, off, on, and off in rapid succession, it will not draw excessive currents although the thermistor is warm and its impedance is low. This extends the life of the input switch (S2) and minimizes power line disturbances.

Initially, housekeeping power is provided to the control circuits through a linear regulator (Q1). Once the power supply comes on, this regulator is back-biased and turned off to save power and reduce heating.

DRIVE AND CLOCK CIRCUITS

The drive and clock circuit is derived from a SG3525A integrated circuit (U3). It drives the power transistors (Q2, Q3, Q4, Q5) at 25 kHz, which, in turn, provide the ac push-pull drive for the main power transformer (T2).

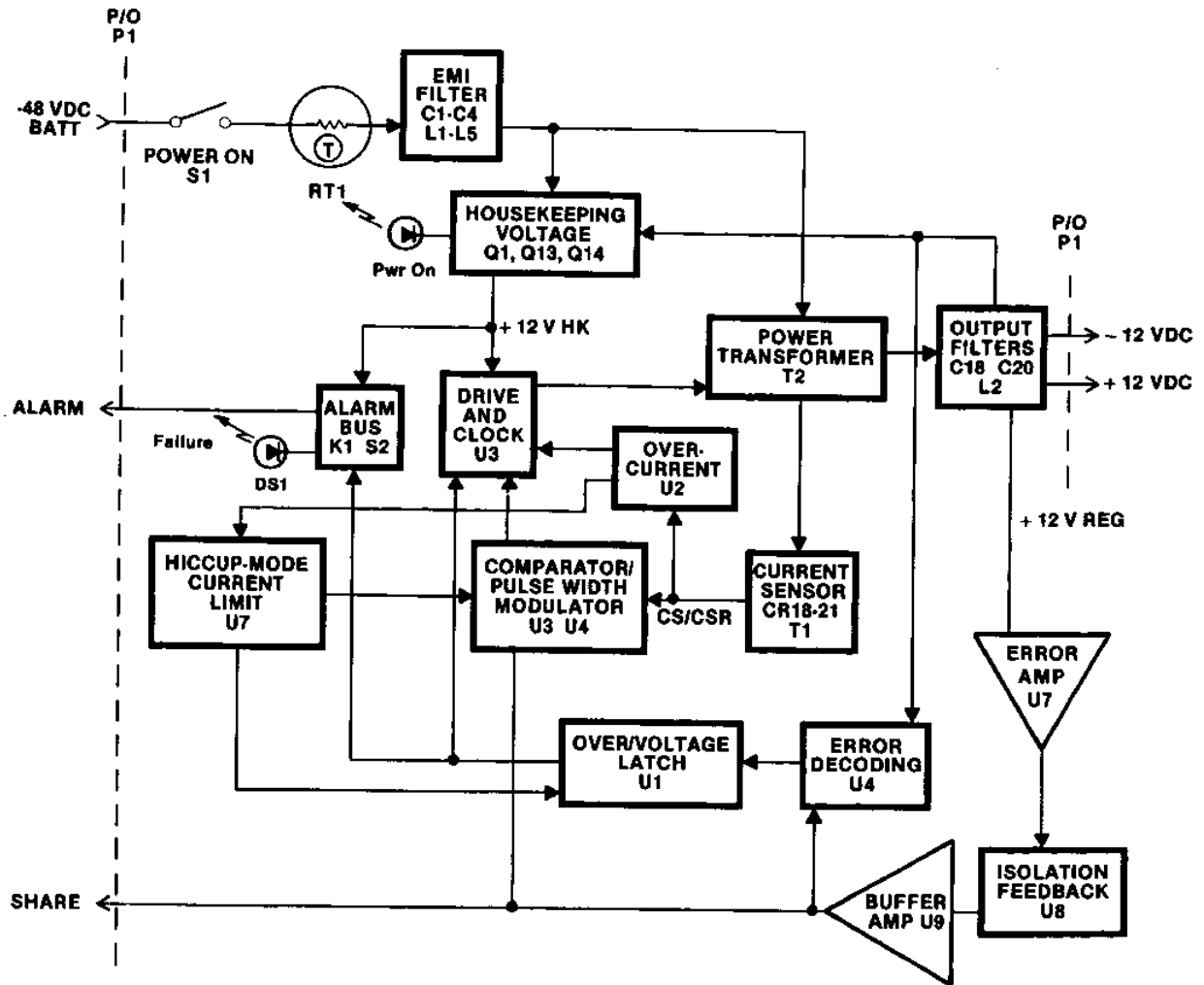

FIGURE 4-1. DPS-7A POWER SUPPLY FUNCTIONAL BLOCK DIAGRAM

OUTPUT CIRCUITS

The output filters (L2, C18, C20) smooth the 50-kHz square wave and produce low ripple outputs (less than 1%). The output filter consists of a toroidal common output filter choke. This design produces low EMI, reduces filter sizes, and increases response to load transients.

Output regulation is provided by the error amplifier (U6), which senses the ± 12 -volt output and compares it to a temperature compensated reference. The high dc gain of the amplifier allows for very tight dc regulation. The error amplifier signal crosses the input-output isolation barrier through an opto-coupler (U8). The coupler voltage isolation is high enough to comply with the FCC part 68 specification of 1500 VRMS. The opto-coupler is used in the linear mode to couple the error amplifier signal to the buffer amplifier (U9).

The power supply operates in the current programmed mode; that is, the error amplifier signal that passes through the buffer determines the primary current in the transformer (T2). A comparator (U4) checks the current in the transformer in a pulse-by-pulse manner to adjust the pulse width of the power supply to obtain the desired output voltage.

Ease of paralleling power supplies, inherent feed-forward, and the reduction of a pole in the feedback path are benefits of the DPS-7A's current mode control. Thus, redundant power supplies share the function of supplying the load current because the supplies are current programmed. Redundant sharing is achieved by connecting the share signals of each supply together (see Section 2, Figure 2-2).

CAUTION

Redundant battery systems with common positive terminals (Figure 2-2) are not compatible with the power supply when the power supply's "share" function is used. Refer to Figure 2-1, and place option switches X1 and X2 located on the printed circuit card to the OUT position.

OVERCURRENT SHORT CIRCUIT AND OVERVOLTAGE PROTECTION

The power supply circuitry includes overcurrent short circuit and overvoltage protection circuits. Overcurrent protection (CR18, CR19, CR20, CR21, T1, U2) limits output currents to a total of 17 amperes maximum. If the overload is severe enough so that the output voltage falls below 10 V dc, a comparator (U1) enables the "hiccup-mode" current limiting circuit (U7). The hiccup-mode circuit disables the supply by discharging C8 and C13 and allows the supply to soft-start.

The overvoltage function (U1, U4) is more complex because of the power supply's redundant mode capability. During redundant mode operation, one buffer amplifier signal controls both power supplies. In order to determine which power supply has failed, an error decoding

circuit samples the power transformer housekeeping output and the buffer amplifier circuits. By decoding the failure, the faulty power supply is identified and turned off by means of the overvoltage latch (U1). A latched state can be removed by turning off the power supply, waiting 20 seconds, then turning it back on; however, if an overvoltage failure still exists, the power supply will turn off again.

ALARM

The alarm bus consists of a nonlatching relay (K1) with detection circuitry. The relay can be in an alarm state if one of the following conditions exists: output overvoltage or undervoltage, short circuit on the output, blown input fuse, or no input power. The alarm relay uses two sets of contact closures (dual form-C relay). One set can be disabled by the ALARM norm/disable front panel switch, (S2). In conjunction with the alarm relay, there is the Failure front panel indicator (DS1) that turns on during alarm conditions.

SECTION 5

TESTS

OVERVIEW

This section describes the tests that may be performed on the DPS-7A power supply when installed in a shelf with other devices. A Technical Assistance Procedure is given at the end of this section.

FUSE REPLACEMENT

An open fuse indicates a possible short circuit in the power supply or the power supply wiring. When a fuse burns out, the green Pwr On LED indicator on the power supply front panel will be extinguished. Turn off the power supply and replace the fuse (located on the pc card) with another 7A 3AG fuse. Turn on the power supply. If the fuse burns out again, replace the power supply with a spare and notify your repair facility.

NOTE

All GDC plug-in devices that may be used with this power supply are independently fused on the pc card. In the event of a short on a single card, the fuses on the card will burn out but the fuse on the power supply will not be affected.

TECHNICAL ASSISTANCE PROCEDURE

For technical assistance, customers should call DataComm Service Corporation at 203-598-7526.

In Canada:

General DataComm (Canada) Ltd.
Service and Repair Facility
1790 Beaulac Street
St. Laurent, Montreal, Quebec H4R 1W8
Telephone: 1-514-336-5454
TWX: 610-421-3221
Telex: 05824085

In the United Kingdom, contact the GDC area manager at:

General DataComm (U.K.) Ltd.
Molly Millars Close
Molly Millars Lane
Wokingham, Berkshire
England RG11 2QF
Telephone: 011-44-734-774-868
Telex: 851 847298
Fax: 011-44-734-774-871

In Europe/Africa/Middle East:

General DataComm
3 Batiment Saturne
Parc Club Ariane
Rue Helene Boucher
78284 Guyancourt Cedex, France
Tel: 011-33-1-30570200
Fax: 011-33-1-30443794

In the Pacific:

General DataComm Pty.
Suite 404
275 Alfred Street North
North Sydney, NSW 2060, Australia
Tel: 011-61-2-956-5099
Fax: 011-61-2-956-5083

In Asia:

General DataComm
401 Centry Square
1-13 D'Aguilar Street
Central, Hong Kong
Tel: 011-852-5265511
Telex: 780-80579
Fax: 011-852-5259944

In Latin America:

General DataComm, International
1579 Straits Turnpike
P.O. Box 1299
Middlebury, Connecticut 06762-1299
Telephone: 203-574-1118
Telex: 7400905
Fax: 203-758-9518

To return a unit for repair, *if so authorized by GDC*, use the return tag and address the package:

Product Repair Department
General DataComm, Inc.
P.O. Box 1299
Middlebury, Connecticut 06762-1299

Lease and Maintenance contract customers may call DataComm Service Corporation toll-free at 1-800-243-1030, 24 hours a day, 7 days a week for trouble reporting or installation scheduling. (Installations are normally scheduled between 8 a.m. and 5 p.m.)

TRAINING

Hands-on training courses are available from DataComm Service Corporation's Educational Services in the USA and in the UK. Courses offered range from basic data communications, modems and multiplexers, to complex network systems, and are given at GDC's Connecticut facility or at a customer's location.

For information call:

USA (203) 574-1118, Ext. 6190.
UK 011-44-734-774-868

SECTION 6
PARTS LIST

OVERVIEW

Table 6-1 provides information to facilitate the identification and procurement of parts for maintenance of the GDC DPS-7A Power Supply. Given are the quantity of the part, GDC part number, part description, and reference designation.

TABLE 6-1. PARTS LIST DPS-7A PCB (041P023-001)

Qty.	Part No.	Description	Reference Designation
4	163-017-001	Heatsink	CR16-K1, CR18-K1, Q5-K1, Q7-K1
8	163-017-101	Heatsink	CR16-K2, CR16-K5, CR18-K2, CR18-K5, Q5-K2, Q5-K5, Q7-K2, Q7-K5
11	208-032-387	Connector	TP1,2, X1,2
1	212-300-001	Switch Dipswitch	FPNL1-K2
1	212-705-222	Switch Dipswitch	S1
1	215-300-700	Fuse, 7.000 A, FB 250 V	F1
1	217-031-003	Relay	K1
2	235-001-001	Core Torroid	L2,3
1	321-001-002	Thermistor	RT1
2	405-120-392	Capacitor	C17,18
1	420-007-001	Capacitor	C1
1	435-006-301	Capacitor	C7
2	435-007-103	Capacitor	C15,16
2	435-009-501	Capacitor	C2,3
2	435-010-105	Capacitor	C19,24
1	435-017-471	Capacitor	C26
1	515-005-001	IC, Timer	U4
1	515-021-001	IC, interface	U5
1	540-017-001	IC, Op Amp	U9
2	540-024-001	IC, Regulator	U2,7
1	540-027-001	IC, Comparator	U1
2	540-032-001	IC, Volt Comparator	U3,6
1	590-005-001	IC, Opto Coupler	U8
1	600-001-001	Transistor	Q11
4	601-001-001	Transistor	Q2,3,4,9
2	612-002-003	Transistor	Q1,10
4	621-002-001	Transistor	Q5,7
1	655-003-001	Diode Rectifier	CR1
4	655-011-001	Diode Rectifier	CR16,18

TABLE 6-1. PARTS LIST DPS-7A PCB (041P023-001)

Qty.	Part No.	Description	Reference Designation
1	665-008-001	LED, Red	DS1
1	665-008-002	LED, Green	DS2
1	700-050-003	Transformer Switching	T1
1	730-017-001	Inductor	T2
1	730-018-002	Inductor	L1
1	730-019-002	Inductor	L4
2	300-007-027	Resistor	R56,58
4	300-007-100	Resistor	R48,75,77,78
7	300-007-103	Resistor	R13,15,49,52,69,74,79
1	300-007-105	Resistor	R17
7	300-007-152	Resistor	R16,29,30,50,55,81,85
1	300-007-164	Resistor	R63
1	300-007-224	Resistor	R36
5	300-007-243	Resistor	R12,18,19,37,53
1	300-007-334	Resistor	R62
3	300-007-363	Resistor	R7,9,14
11	300-007-512	Resistor	R1,24,28,39,44,45,54,61,70,71,84
1	300-007-823	Resistor	R66
1	300-020-101	Resistor	R57
2	300-020-102	Resistor	R40,41
1	300-020-392	Resistor	R8
4	300-020-470	Resistor	R20,21,22,23
3	305-055-071	Resistor	R2,5,10
6	305-055-101	Resistor	R11,25,26,42,43,51
4	305-055-159	Resistor	R32,38,47,82
4	305-055-021	Resistor	R31,35,67,76
2	305-055-240	Resistor	R64,65
2	305-055-242	Resistor	R6,80
1	305-055-256	Resistor	R46
1	305-055-285	Resistor	R73
2	305-055-305	Resistor	R3,83
1	305-055-308	Resistor	R33
2	305-055-333	Resistor	R60,68
3	305-055-342	Resistor	R4,34,72
2	305-055-401	Resistor	R27,59
6	405-100-103	Capacitor	C5,6,12,25,27,28
2	405-100-471	Capacitor	C8,33
2	405-200-222	Capacitor	C9,20
1	405-200-470	Capacitor	C4
11	405-300-104	Capacitor	C10,11,13,14,21,22,23,29,30,31,32
18	650-001-001	Diode Switch	CR2,3,4,5,6,7,8,9,10,11,12,13,22,23,24,25,26,27
4	655-008-002	Diode Rectifier	CR14,15,20,21
2	660-001-006	Diode Zener	VR3,5
1	660-001-014	Diode Zener	VR4
2	660-001-022	Diode Zener	VR1,2

SECTION 7 DIAGRAMS

OVERVIEW

This section contains mechanical, component board, wiring, and schematic drawings intended for reference by a technician. These drawings aid service personnel in isolating the causes of malfunctions in the power supply.

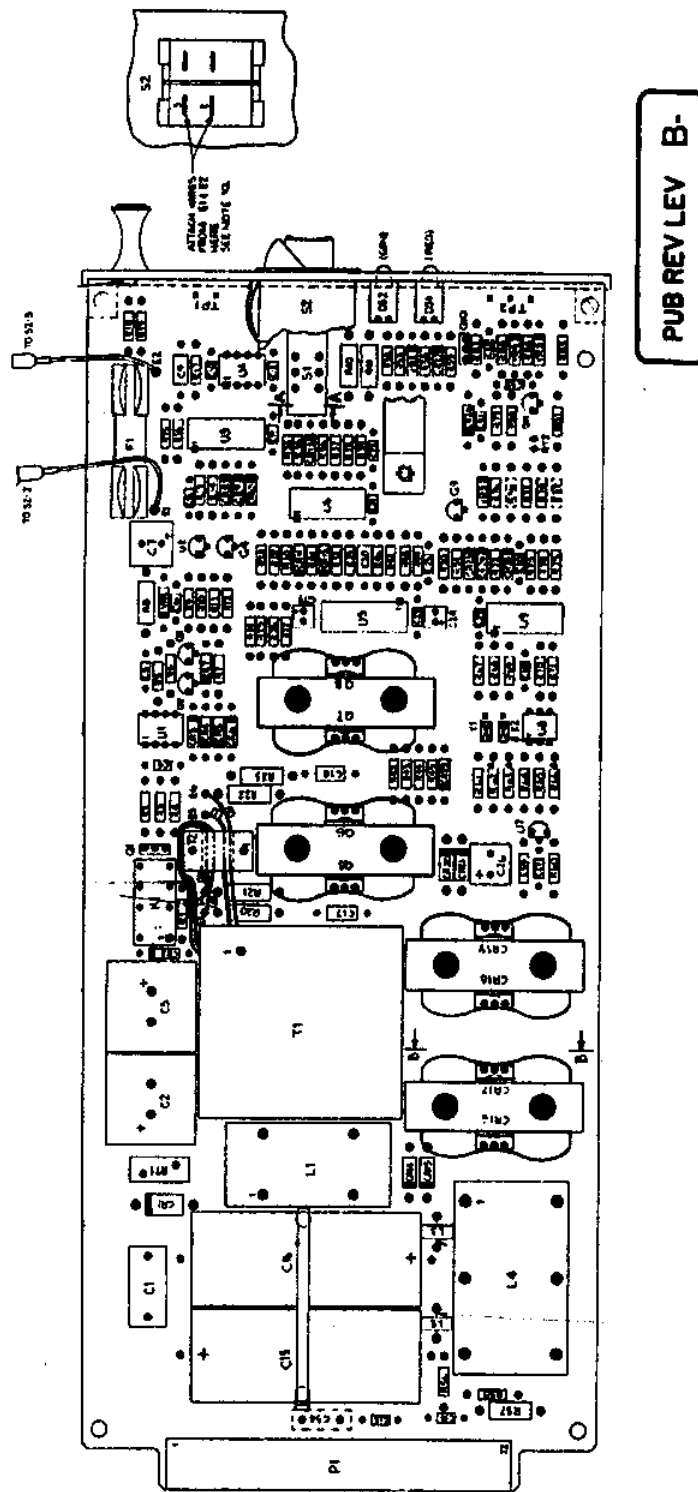

FIGURE 7-1. DPS-7A POWER SUPPLY PCB ASSEMBLY DIAGRAM (041P023-002)

APPENDIX A TECHNICAL CHARACTERISTICS

Item	Specification
Electrical	
Power supply	
Input	-42 to -56 V dc from station battery.
Output	+ 12 V dc \pm 4% 0.25A to 7.5 A and -12 V dc \pm 4% 0.25A to 6.6A.
Wattage	160 watts maximum (depends on the amount of devices installed in the shelf).
Power dissipation	Less than 35 watts at full load, per supply.
Fuse Size/type	7A #AG fuse on pc card.
Open fuse indication	Green Pwr On indicator is off when fuse is blown and POWER on/off switch is in "on" position. Red Failure indicator is on if output voltages are out of specifications.
Input under/over voltage protection	The power supply will not be damaged by any input from 0 to 56 V dc.
Reverse input voltage protection	Protective circuitry and fusing prevent damage from reverse battery-polarity connection.
Output over-voltage protection	The power supply will shut down due to an internal malfunction causing an over-voltage condition. Maximum output is \pm 15 V dc.
Overload protection	The power supply will not sustain damage due to an indefinite overload or short circuit on the \pm 12 V dc output lines. Maximum overload is 200 watts.
Short circuit protection	The power supply will not sustain damage due to an indefinite short circuit on the \pm 12 V dc output lines. "Hiccup" current limiting protection keeps average current below 3 A.
Temperature	Operating: 0°C (+ 32°F) to 50°C (+ 122°F) Non-operating: -40°C (-40°F) to + 85°C (+ 185°F)
Humidity	Operating and non-operating: Up to 95% without condensation.
Power supply connectors	
Battery	One six-position screw-type barrier strip on the power supply harness card for connecting one or two station batteries. Also provides connections to signal and frame grounds.
Alarm (A and B)	Two 7-pin headers which provide remote indication from each power supply in the event of power supply failure. Provided on isolated dual form-C relay contacts. One set can be activated/deactivated by front panel ALARM disable/norm switch. Relay contacts are rated at 0.25A at 140V, with a resistive load.

APPENDIX B

GLOSSARY

Brownout Protection	Protection of the supply and external loads from an excessive reduction in input voltage.
Comparator	A circuit that compares two signals and supplies an indication of agreement or disagreement.
Cross-Regulation	In switched power supplies, the percentage change in auxiliary output voltage resulting from a specified change in the main (closed loop) output current.
Current Limiting	A current overload protection mechanism that limits the maximum output current to a preset value for conditions of load resistance or short circuit.
Dropout Voltage	The decreased input voltage at which the supply (or regulator) ceases to regulate the output for further decreases in input voltage.
Electromagnetic Interference (EMI)	Undesirable signals that can directly or indirectly contribute to a degradation in performance in equipment.
Error Signal	The amplified difference between the sampled output voltage and a fixed reference voltage.
Feed Forward	Design technique that may be used to compensate changes in line voltage, thereby improving input line regulation and reducing output low frequency ripple.
Filter Capacitor	In power supplies; a capacitor (usually electrolytic) used to block undesirable frequencies.
Filter Choke	Normally, an iron-core or toroidal coil that allows direct current to pass while restricting the passage of pulsating or alternating current.
Foldback	Means whereby the output current is reduced to a low percentage of rated output current for severe overloads or short circuits.
Housekeeping	In power supplies, those operations that contribute directly to the proper operation of the power supply.
In-rush Current	The maximum input current drawn by the supply when input power is applied.
Line Regulation	Refers to the maximum change in output voltage (or current) resulting from changes in input (line) voltage, normally specified from minimum input voltage to maximum input voltage.
Load Regulation	Refers to the maximum change in output voltage (or current) resulting from changes in load resistance (load), normally specified from no load to full load.
Minimum Load	The decreased output current at which the supply ceases to regulate for further decreases in output current.
Operating Temperature	Temperature range (ambient or case) over which a supply can be safely operated at rated output. Output power may be derated to a specified value at a higher specified temperature.

SECTION 041R171-000-B

Output Impedance	The incremental change in output voltage divided by a forced incremental change in output current over a specified frequency range.
Overvoltage Protection	Protection of the supply and externally connected loads against excessive output voltage, either from internal or external causes.
Power Transistor	A transistor capable of handling high current and power.
Recovery Time (Voltage Regulation)	Time required for the output voltage to return to a value within the regulation limits after a step change in line or load.
Recovery Time (Current Regulation)	Time required for the output current to return to a value within the regulation limits after a step change in line or load. For load changes, recovery will be governed by the rate of change of compliance voltage across the load.
Redundancy	The employment of several devices, each performing the same function, in order to improve the reliability of a particular function.
Regulated Power Supply	A unit that maintains a constant output voltage or current for changes in line voltage, output load, ambient temperature, or time.
Remote Sense	The means by which the output voltage is directly monitored and regulated at the external load. This mode compensates for voltage drops in the output wiring leads.
Ripple	Stated either as a peak-to-peak or rms value of an ac component (typically from dc to 1 MHz) appearing in the output voltage or current.
Share function	The share function forces two power supply modules to "share" equally in supplying the load.
Short Circuit Protection	Any automatic current limiting that enables the supply to continue operating, without damage, when a short circuit is applied across the output terminals.
Station Battery	A separate battery power source within a facility that provides all dc input power requirements associated with the facility. Such a capability is often centrally located.
Thermistor	A solid state semiconducting device, the electrical resistance of which varies with the temperature. Its temperature coefficient of resistance is high, nonlinear, and negative.
Toroidal Coil	A highly efficient type of coil wound around a ring or "doughnut" type of core. The toroid provides for a highly concentrated magnetic field within itself and has a minimum magnetic flux leakage (external field).
Transformer	An electrical device that, by electromagnetic induction, transforms electrical energy from one or more circuits to another.
Transient	A momentary surge on a power line. It may produce false signals or triggering impulses and cause insulation or component breakdown and failures.
Turn-on-Time	The time required for the output voltage (or current) to reach regulation limits after input power is applied.
Warm-up-Time	The time required for the supply to meet specified operation (regulation and ripple as well as a minimum) after power is applied. This time may be a function of ambient temperature at the time power is applied.

INDEX

- Alarm
 - cable, 1-2
 - circuit principles, 4-1-4-4
 - indicators, 3-1, 3-2
- Common battery, 2-2, 2-3
- Connectors, 3-2
 - alarm, 2-2
 - station battery, 2-2
- Drive and Clock Circuits, 4-1
- Fault isolation, 5-1
- Features, 1-1
- Frame ground, 3-3/4
- Front panel, 3-2
 - controls, 3-2
 - illustration, 3-2
 - indicators, 3-2
- Functional block diagram, 4-2
- Fuse
 - location, 2-5
 - rating, 2-5
- Glossary, B-1
- Indicators, 3-2
- Input circuits, 4-1
- Installation
 - physical, 2-1
 - electrical, 2-2
 - primary, single battery, 2-2
 - primary, two batteries, 2-2
 - redundant battery, common positive, 2-2
 - Non-redundant, 1-1
 - Option location, 2-4, 2-5
 - Overcurrent, 4-3 4-4
 - Overvoltage, 4-4
 - Parts list, 6-1
 - Physical description, 1-1
 - Preoperational check, 2-1
 - Primary power, 2-2
 - Redundant, 2-2
 - Schematics, 7-1
 - Share function, 2-2
 - Signal ground, 3-3/4
 - Specifications, A-1/2
 - Station battery, 2-4
 - Status indicators, 3-2
 - Switched power supply, 1-1
 - Technical Assistance Procedure, 5-1, 5-2
 - Technical characteristics, A-1/2
 - Test points, 2-1, 3-2
 - Training, 1-1
 - Unpacking and handling, 2-1

